

Fully coated multilayer SBS board with light coated reverse

Ensocoat is a luxurious, coated SBS (solid bleached sulphate) board with a three-layer fibre construction of chemical pulp. It is double-coated on the top side, with one layer of coating on the reverse side. The reverse side is coated with transparent LDPE.

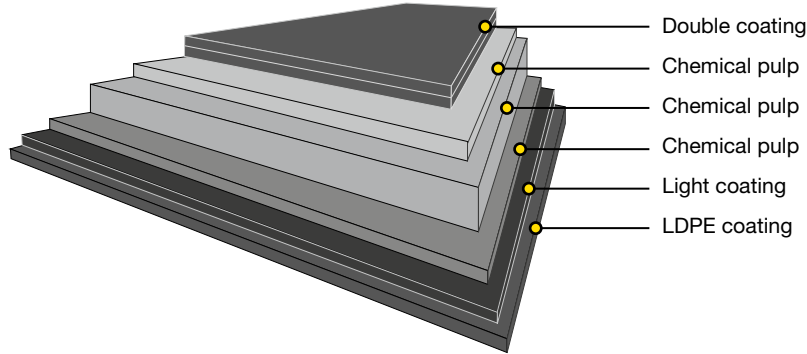

Issued: 09.2023
Cancels: 09.2021

Technical specification

Property / Unit	Tolerance	190+15	210+15	230+15	250+15	275+15	300+15	330+15	350+15	380+15	Standards
Polymer coated board:											
Grammage, g/m ²		205	225	245	265	290	315	345	365	395	ISO 536
LDPE Reverse, g/m ²		15	15	15	15	15	15	15	15	15	Mill method
Thickness, µm		213	243	283	313	343	378	428	458	498	ISO 534
Baseboard:											
Grammage, g/m ²	±4%	190	210	230	250	275	300	330	350	380	ISO 536
Thickness, µm	±4%	200	230	270	300	330	365	415	445	485	ISO 534
Bending resistance L&W 15° MD, mN	-15%	75	105	160	210	270	375	500	580	740	ISO 2493-1
Bending resistance L&W 15° CD, mN	-15%	35	50	75	100	130	180	240	270	350	
Bending moment Taber 15° MD, mNm	-15%	3.6	5.1	7.7	10.1	13.0	18.1	24.2	28.0	35.7	
Bending moment Taber 15° CD, mNm	-15%	1.7	2.4	3.6	4.8	6.3	8.7	11.6	13.0	16.9	
Bending stiffness DIN 5° MD, mNm	-15%	6.4	8.9	13.6	17.9	23.0	31.9	42.5	49.3	62.9	
Bending stiffness DIN 5° CD, mNm	-15%	3.0	4.3	6.4	8.5	11.1	15.3	20.4	23.0	29.8	
Moisture, %	±1, ±1.5 *	6.5	6.5	6.5	6.5	6.5	6.5	6.0	6.0	6.0	ISO 287
ISO Brightness C/2°, %, Top	min. 92	95	95	95	95	95	95	95	95	95	ISO 2470-1
ISO Brightness C/2°, %, Reverse	min. 90	93	93	93	93	93	93	93	93	93	
Brightness D65/10°, %, Top		103	103	103	103	103	103	103	103	103	ISO 2470-2
CIE Whiteness D65/10°, Top		135	135	135	135	135	135	135	135	135	ISO 11475
CIE Whiteness D65/10°, Reverse		130	130	130	130	130	130	130	130	130	
L* D65/10°, Top		96.5	96.5	96.5	96.5	96.5	96.5	96.5	96.5	96.5	ISO 5631-2
a* D65/10°, Top		2.5	2.5	2.5	2.5	2.5	2.5	2.5	2.5	2.5	
b* D65/10°, Top		-10.5	-10.5	-10.5	-10.5	-10.5	-10.5	-10.5	-10.5	-10.5	
Surface Smoothness PPS 10, µm, Top	max. 1.4	0.9	0.9	0.9	0.9	0.9	0.9	0.9	0.9	0.9	ISO 8791-4
Surface Smoothness PPS 10, µm, Reverse		<4.0	<4.0	<4.0	<4.0	<4.0	<5.0	<5.0	<5.0	<5.0	
Surface Smoothness Bendtsen, ml/min, Top		20	20	20	20	20	20	20	20	20	ISO 8791-2
Surface Smoothness Bendtsen, ml/min, Reverse		<100	<100	<200	<200	<200	<200	<300	<300	<400	
Gloss 75°, %, Top		48	48	48	48	48	48	48	48	48	ISO 8254-1
Scott Bond, J/m ²	min. 140	220	220	220	220	220	220	220	220	220	TAPPI 569
Robinson chocolate test		Max 1 for one year storage in reels/pallets									EN 1230-2

*) For 330 – 380 g/m²

All properties according to Imatra Mill measurements from board machine production.

Laboratory test climate 23°C/50% RH (According to ISO 187).

Tolerances based upon 95% confidence limits, apply to delivered reel/pallet average.

Bending moment Taber 15° and Bending resistance L&W 15° are binding, Bending stiffness DIN 5° are indicative.

Bending moment Taber 15° calculated from Bending resistance L&W 15°.

Fully coated multilayer SBS board with light coated reverse

Certificates

Quality management ISO 9001
 Environmental management ISO 14001
 Product safety FSSC 22000
 Occupational health and safety ISO 45001
 Energy management ISO 50001



FSC and PEFC certified board available upon request.



Paperboard can be recycled

Key characteristics and main enduses

Ensocoat is Stora Enso's flagship board, crafted to meet the demands of the graphical industry and luxury packaging. Its surface smoothness, printing performance, brightness, whiteness, UV-light resistance and reverse-side print result have been optimized to impress even in the most demanding applications. Produced from responsibly sourced, certified raw materials, it serves as the industry standard for high performance and sustainability. Ensocoat PE provides excellent value, performance and visual appearance in applications that require protection against humidity. Ensocoat PE is mainly used for chocolate and confectionery and food end uses. Thanks to the three-layer fibre construction, Ensocoat has outstanding strength, folding, embossing and converting properties.

Printing and finishing techniques

The product can be used with different printing techniques such as offset, flexo and rotogravure. The product works very well with different finishing techniques, such as embossing, hot foil stamping and others. The top side of the board is suitable for laser coding. Certificate according to PTS-DF 105/2019 is available upon request.

Storage recommendations

For optimal printing results, the moisture proof wrapping should not be removed until the board has reached the temperature of the press room.

Pallet/Reel Weight (kg)	Difference in temperature between board and press room (press room temp. approx. 20°C)		
	10°C	20°C	30°C
400 kg	2 days	2 days	3 days
800 kg	2 days	3 days	4 days
1200 kg	2 days	4 days	5 days

The product properties, according to the specifications, are guaranteed for 12 months after the production date.

In order to ensure product safety, the product must be well wrapped and stored in its original cover indoors, sheltered from rain and snow. The recommended storage conditions are 50-55% relative humidity and 20-23°C.

For the Corona treatment, we recommend using the board within 12 months of the production date; after this period, the treatment level should be tested before printing or gluing.