

Fully coated CTMP board with light pigment-coated reverse

Performa White PE is a polyethylene-coated GC1 board with a three-layer fibre construction and CTMP (chemi-thermomechanical pulp) in the middle layer. It is triple-pigment-coated on the top side, and the reverse white side is coated with transparent LDPE. Performa White PE is also available hard-sized (HS).

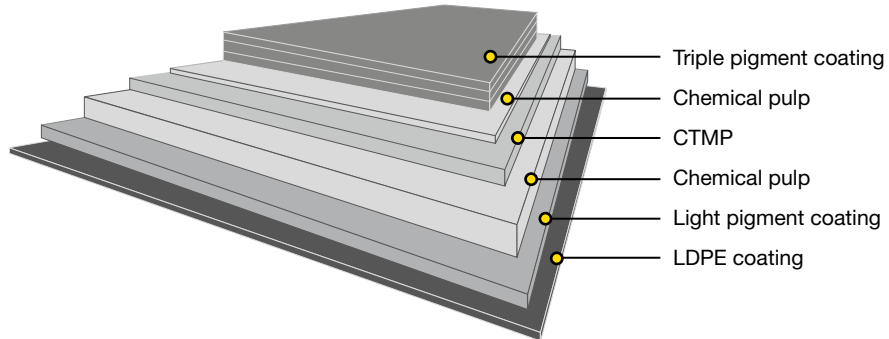

Issued: 11.2023
Cancels: 02.2023

Technical specification

Property/ Unit	Tolerance	200+20	220+20	240+20	260+20	280+20	300+20	315+20	325+20	350+20	370+20	400+20	Standards
Polymer coated board:													
Grammage, g/m ²		220	240	260	280	300	320	335	345	370	390	420	ISO 536
LDPE reverse side, g/m ²		20	20	20	20	20	20	20	20	20	20	20	Mill method
Thickness, µm		315	345	385	420	460	495	525	555	605	645	695	ISO 534
Baseboard:													
Grammage, g/m ²	±4%	200	220	240	260	280	300	315	325	350	370	400	ISO 536
Thickness, µm	±5%	295	325	365	400	440	475	505	535	585	625	675	ISO 534
Bending resistance L&W 15° MD, mN	-15%	160	201	265	353	445	535	608	690	800	900	1080	ISO 2493
Bending resistance L&W 15° CD, mN	-15%	73	92	120	160	202	243	276	290	370	410	500	
Bending moment Taber 15° MD, mNm	-15%	7.7	9.7	12.8	17.0	21.5	25.8	29.3	33.3	38.6	43.5	52.2	
Bending moment Taber 15° CD, mNm	-15%	3.5	4.4	5.8	7.7	9.8	11.7	13.3	14.0	17.9	19.8	24.2	
Bending stiffness DIN 5° MD, mNm	-15%	14.3	18.2	24.4	33.7	43.0	51.3	59.1	66.8	78.7	91.7	109.8	
Bending stiffness DIN 5° CD, mNm	-15%	6.5	8.3	11.5	14.3	18.3	22.4	25.9	30.9	35.9	42.7	51.5	
Moisture, %	±1, ±1.5 *	7.0	7.0	8.0	8.1	8.3	8.6	8.7	8.7	8.9	9.1	9.3	ISO 287
ISO Brightness C/2°, %, Top	min. 87	90	90	90	90	90	90	90	90	90	90	90	ISO 2470-1
ISO Brightness C/2°, %, Reverse	min. 85	88	88	88	88	88	88	88	88	88	88	88	
Brightness D65/10°, %, Top		97	97	97	97	97	97	97	97	97	97	97	ISO 2470-2
CIE Whiteness D65/10°, Top		120	120	120	120	120	120	120	120	120	120	120	ISO 11475
CIE Whiteness D65/10°, Reverse		114	114	114	114	114	114	114	114	114	114	114	
L*, Top		95.0	95.0	95.0	95.0	95.0	95.0	95.0	95.0	95.0	95.0	95.0	ISO 5631-2
a*, Top		1.7	1.7	1.7	1.7	1.7	1.7	1.7	1.7	1.7	1.7	1.7	
b*, Top		-7.2	-7.2	-7.2	-7.2	-7.2	-7.2	-7.2	-7.2	-7.2	-7.2	-7.2	
Surface Smoothness, PPS 10, µm, Top	max. 1.7	1.0	1.0	1.0	1.0	1.0	1.0	1.0	1.0	1.0	1.0	1.0	ISO 8791-4
Surface Smoothness, PPS 10, µm, Reverse	max. 8.4, 9.0 ****	6.4	6.4	6.4	6.4	6.4	6.4	6.4	6.4	6.4	6.4	6.4	
Gloss 75°, %		45	45	45	45	45	45	45	45	45	45	45	ISO 8254-1
Scott Bond, J/m ²	min. 100	145	145	145	145	145	145	145	145	145	145	145	TAPPI 569
Edge wicking**, g/mm.m	max. 1.0	0.5	0.5	0.5	0.5	0.5	0.5	0.5	0.5	0.5	0.5	0.5	
Cobb 60, g/m ² , Top	max. 60	30	30	30	30	30	30	30	30	30	30	30	ISO 535
Robinson chocolate test		max 0.5 for one year storage in reels/pallets											EN1230-2

*) For 325 – 400 g/m²
**) For Hardsized
***) Preliminary values
****) For 350-400 g/m²

All properties according to Fors Mill measurements from board machine production.
Laboratory test climate 23°C/50% RH (According to ISO 187).
Tolerances based upon 95% confidence limits, apply to delivered reel/pallet average.
Bending moment Taber 15° and Bending resistance L&W 15° are binding, Bending stiffness DIN 5° are indicative.
Bending moment Taber 15° calculated from Bending resistance L&W 15°.

Performa White™ PE

Fully coated CTMP board with light pigment-coated reverse

Certificates

Quality management ISO 9001
 Environmental management ISO 14001
 Product safety FSSC 22000
 Occupational health and safety ISO 45001
 Energy management ISO 50001



FSC and PEFC certified board available upon request.



Paperboard can be recycled

Key characteristics and main enduses

Performa White PE provides excellent value, runnability and performance in applications that require protection against humidity. Performa White PE is an aesthetically appealing board that combines performance with a beautiful white appearance. This board is ideal for chocolate and confectionery, and is also used for frozen and chilled food products. Thanks to the triple-pigment-coated top side, Performa White PE gives a very good print result. The high brightness and whiteness contribute to optimal visual appearance.

Printing and finishing techniques

The product can be used with different printing techniques such as offset, flexo and rotogravure. The product works very well with different finishing techniques, such as embossing, hot foil stamping and others. It is suitable for laser coding and ink jet marking. Certificates according to PTS-DF 105/2019 and PTS-DF 103/2022 are available upon request..

Storage recommendations

For optimal printing results, the moisture proof wrapping should not be removed until the board has reached the temperature of the press room.

Pallet/Reel Weight (kg)	Difference in temperature between board and press room (press room temp. approx. 20°C)		
	10°C	20°C	30°C
400 kg	2 days	2 days	3 days
800 kg	2 days	3 days	4 days
1200 kg	2 days	4 days	5 days

The product properties, according to the specifications, are guaranteed for 12 months after the production date. In order to ensure product safety, the product must be well wrapped and stored in its original cover indoors, sheltered from rain and snow. The recommended storage conditions are 50-55% relative humidity and 20-23°C.

For the Corona treatment, we recommend using the board within 12 months of the production date; after this period, the treatment level should be tested before printing or gluing.