

# The future of Timber Construction CLT – Cross Laminated Timber

A study about changes, trends and technologies  
of tomorrow

Photo: MHD Arkitekter

A study in collaboration with Stora Enso

**External project consultant**

Georg Guntschnig

**Publisher**

Zukunftsinstitut Österreich GmbH  
Rudolfsplatz 12/6, 1010 Vienna  
Tel.: +43 (0) 1 943 4030  
Fax: +43 (0) 1 253 30 33 40 30  
office@zukunftsinstitut.at  
www.zukunftsinstitut.at

**Editor-in-chief**

Harry Gatterer

**Project management**

Christiane Varga

**Authors**

Oona Horx-Strathern  
Christiane Varga  
Georg Guntschnig

**Editorial assistance**

Marina Lordick  
Stefan Sutterlüty

**Graphic design**

Ksenia Pogorelova

**Editor**

Franz Mayer

© Zukunftsinstitut GmbH, June 2017  
All rights reserved.

Should you have any questions please  
get in touch with our official contact  
Georg Guntschnig  
**Georg.Guntschnig@edu.campus02.at**

**Page 6**

**Risking the Future:** Social Changes through Megatrends

**Page 12**

**Wood as a Material:** A Renaissance in Timber Construction

**Page 26**

**The Massive Wood Market**

**Page 30**

**From Space to Place:** Urbanisation on the Rise

**Page 38**

**Changing Demographics**

**Page 46**

**Future Customers:** How will we live in the Future?

**Page 54**

**Wevolution:** New Forms of Society and Cooperation

**Page 60**

**The Voices of Industry:** Expert Survey on Tomorrow's Timber Construction

**Page 74**

**Technology and Innovation**

# Foreword

If the terms naturalness, comfort and ecology are considered in the context of using materials for building future-oriented architecture, then it becomes apparent relatively quickly that this must concern the raw material wood.

Whether we are thinking about designer elements for defining high-quality architecture or focusing on the realisation of contemporary and sustainable buildings, wood as a natural raw material has established its position and is currently undergoing a revival quite unlike any other.

Wood is trending: it is renewable, can be used in many ways and makes a contribution to climate protection as part of our responsibility to the generations after us.

Wood is certainly one of the world's oldest construction materials and this unique material has long been associated with tradition and rural cosiness.

Since the start of the new millennium, wood has found a niche in the new, modern and not least urban society, thanks to the material's availability, various social developments and new technical possibilities.

What building in wood is all about is shown by the many award-winning showcase projects throughout the world, which communicate this positive development and make an important contribution to increasing the use of wood. Continuous technical development, the resulting new wood-based materials and, above all, society's ever-rising consciousness of ecology and of the need for sustainable management of our available resources are further reasons why wood will be THE material of the 21st century.

This study, which has its origins in scientific work, serves to identify present and future trends relevant to the future of timber construction. It seeks to widen the perspective of issues already known to the industry and raise awareness of social and technological developments and trends.

The scientific approach, together with the Zukunftsinstitut and in dialogue with universities, architects and acknowledged experts, develops an exciting perspective, highlights prospective opportunities and potential and offers a future roadmap on a corporate strategic level. Required reading for everyone who wishes to be actively involved in shaping the future of the timber construction industry.

We hope what you read will inspire you.



**Herbert Jöbstl**  
SVP Stora Enso  
Wood Products  
Central Europe

# Foreword

Without consciously thinking about it, people in Europe spend most of their lives in buildings. We have become so used to living in buildings that we take it for granted and as completely normal. With all their convenience – offering everything from running water to electricity, from heat to all kinds of entertainment and everyday effort-saving devices. In recent decades, we have concentrated mainly on developing interior spaces: How big a floor area do we need? What materials shall we use? How can I tailor the space as individually as possible to my requirements? In commercial real estate as well, most activity centres on interpreting building interiors in new ways. This could concern concepts for environments to suit “New Work” styles or buildings for the hotel trade and their more demanding requirements for the modern client.

With this kind of strong focus on interiors and the use of space, it is no wonder that we scarcely spared a thought for the building itself. Almost everyone’s attention hardly wandered any further than concepts for building use. Now, because we have learned which building use concepts we need in the 21st century, we have been able to direct the interest of a whole industry back to the design and quality of buildings. New questions emerge: What shall I do with the building after it has reached the end of its useful life? How can we think in terms of lifecycles and not dead ends? How much does a building cost over its lifetime? What materials offer the most to the building’s atmosphere (mood) and future (durability and lifecycle thinking)? How can I build flexibly and change the building’s use by clever structural alterations over time?

The 21st century has already shown that this new focus is already starting to become established in many areas of building. Even

though these only appear as green shoots throughout the entire industry, it is already becoming clear: in the next 20 years, big things are going to happen in terms of the construction of our buildings. Not least because an industry that is fundamentally not very innovative will find it difficult to simply keep doing the same thing. Considering for a moment only the land taken up by buildings, this has already exceeded many earlier limits and will therefore lead to greater restrictions in future. Wood will play an exciting role here as a building material, because – in terms of lifecycle thinking – it is a logical choice for constructing buildings.

In this study we wished to look into these “new” questions and find out what role “wood” will have in particular. We wanted to identify how far we might see ahead and where there are still blind spots. Furthermore, we wanted this publication to provide a foundation for future thinking about building.

Let yourself be inspired!



**Harry Gatterer**  
CEO, Zukunftsinstitut

# Risking the Future

## Social Changes through Megatrends – and their Relevance for the Timber Construction Industry

The media landscape in recent years has been defined by terms such as "bio", "green", "regional" and most notably "sustainability". The last term in particular has been used so often that Dr Daniel Fisher from the Institute for Environmental and Sustainability Communication at the Leuphana University in Lüneburg and some of his students researched the use of the word in German media. Their comprehensive analysis studied six national newspapers published between 1995 and 2014. One of the findings from over 20,000 instances examined was that the word sustainability appeared twice as frequently in 2014 than it did 20 years earlier, at the start of the period studied. However, it was mentioned in only 2% of all published articles. The implication is that media consumers feel that the word "sustainability" comes up more frequently than is actually the case.

It is therefore worth zooming into the detail to discover the context in which the term is used. Dr Fisher and his students found that "sustainable" is used mainly in everyday speech, in the sense of "lasting", "continuing for a long time" or "particularly intense". For example, the word "sustained" could be applied to the finish of a wine. In 2001, over 75% of the word's use was in this context, but by 2003 this figure had dropped to barely 50%. This indicates that the definition of the word has been refined. If the media is handling the word increasingly professionally, then this will affect readers' basic understanding of the term.

The term "sustainability" and its entry into mainstream use is one of the many examples of a megatrend with an astonishing background: from the thematic territory of solo campaigners, idealists and activist groups on the one hand, to politics and the boardroom agendas of large companies on the other – and finally to a meta-theme

of modern society. Good citizens who care about the future and that of their children step forward as conscious consumers ready to wield their power over the market. Labels such as "eco", "bio" and "green" interplaying with "fair" give products the potential to become big sellers, while allowing scope for unpleasant side-effects, such as attempts to make a quick buck out of what turns out to be purely superficial polish. The new, neo-ecological consumer is focusing increasingly on quality, origin and method of production.

### A megatrend generates future markets

Neo-ecology is a megatrend strongly fostered by other megatrends: ecology and health are two sides of the same coin, while mobility and urbanisation are given a new twist by the emergence and strengthening of the neo-ecological mindset. In order to develop a basic understanding of megatrends and their relevance to society as a whole, it is important to be aware of the complexity of megatrends with particular regard to their countless external links.

Megatrends are the deep ocean currents of change. They span several decades as ever-present development constants of global society. At work within every individual, they operate on all levels of society: in the economy and politics just as much as in science, technology and culture.

Megatrends are disconcerting, complex and, from time to time, paradoxical. If we really understand them, they can help us not only to guess the future, but also to shape it.

The Zukunftsinstitut has identified 12 megatrends for the currents of major social change. The term "megatrend" was coined by John Naisbitt. There is no need

to "foresee" megatrends because they are already there. They signal changes that have been shaping us over a long period – and will continue to do so well into the future. To make this a little clearer, the Zukunftsinstitut has developed the Megatrend Map (see next page). Here in version 3.0, it shows the lines of development, relationships, interfaces and linkages of all megatrends. The map serves as the basis for all considerations in this report.

## The megatrends:

---



### Individualisation

A new individuality is establishing a culture of choice that some people find overwhelming. Individualism comes in many varieties: it may be rebellious, hedonistic, extremist, emotional or sensitive. In future, individualism will not be egotistic but increasingly mindful. The megatrend is recursive, in other words it creates a loop in which individualists are seeking a sense of community and reinventing themselves. The developed "I" and the new "we" will be two sides of the same coin in future.

---



### Connectivity

Life is becoming totally networked. Modern communications technology, with the Internet at its heart, confers unbridled power on the Connectivity megatrend. No other megatrend is more capable of change, destruction or creating new. No other megatrend triggers more disruption. Its influence gives rise to new forms of society, cooperation, commercial activity and work. But sometimes there are movements in the opposite direction – we are now more cautious about how we handle the possibilities laid open by connectivity.

---



### Health

Health is no longer just a desirable condition, it has become the aim and meaning of life. This megatrend forges even closer links between psychological and physical

dimensions, merging health and satisfaction. People are taking more responsibility for their health and are more self-confident when dealing with the health systems. Detoxing, exercise and self-tracking are integral components of health as a cultural dimension of modern life.

---



### New Work

Upheavals in society and new processes in the economy lead to fundamental changes in the world of work, thereby defining the New Work megatrend. In such a digitalised and globalised future, work will take on a new meaning in people's lives with work and leisure flowing into one another. Technology is important but not dominant – people are determinant. Their talents count and an era of talent is dawning in the new world of work.

---



### Silver Society

The elderly are increasing in number: the Silver Society megatrend is present worldwide and across all sectors of society. It has sweeping potential because it produces fundamental and lasting changes in systems and infrastructures. At the same time, a new lifestyle defines old age, reshaping society's image of the elderly. Life's phases merge into one another. The old three stages of life, youth – work – retirement, give way to multi-graphical lives. "Un-retirement" is becoming the cultural counter model to the traditional pension model.

---



### Gender Shift

Gender is losing its social significance. This megatrend has wide-ranging consequences for the economy and society – and allows increasing numbers of individuals to become happy in themselves and with their lives. Gender models are fusing together, old roles and career models are finally being consigned to the past. This will cause society to become culturally polarised and categorised in different ways. Retro is also part of this trend – as a chavvy and more flamboyant remake of the old cliché of man and wife.

## The Megatrend Map

The Megatrend Map shows the twelve main megatrends of our time. Megatrends are never linear or unidimensional. They are diverse, complex and intermeshed. The way the information is presented therefore shows not only the trends themselves but also visualises the overlaps and parallels between the megatrends.

The individual stations along a megatrend line in turn clarify the various dimensions, facets and aspects of the trends. They depict the multilayered nature of a megatrend and the diverse influencing factors that act in its sphere.

Megatrends are trends that have an epic and epochal character. We assume their half-life (the time until the zenith of their effect) to be 30 years or more. They change not only individual segments or areas of social life or the economy: they reshape whole societies.









### Neo-ecology

Bio is thoroughly checked for quality, diet is flexible to meatless, industrial systems need to adapt – either to ensure waste-free operation or keep raw materials circulating in a closed loop. Because a consumer culture forged by the Neo-ecology megatrend is on its way. People will no longer just buy, they will exercise greater control over the consumer market. New technologies create new alternatives to the old throwaway society. This has limitless revolutionising potential.

---



### Mobility

The global society is in motion, with both people and data – driven by the Mobility megatrend. Location loses its binding power, home becomes a relative term, being mobile becomes a cultural obligation. Transport facilities become spaces for living and working – the new fixed points in a flowing mobile lifestyle. The automobile forfeits its dominant position and is developed into an autonomous data-driven vehicle. The convergence of social change and new technological possibilities is moving at great speed in the mobility industry.

---



### Urbanisation

The Urbanisation megatrend is as strong as never before: ever-larger megacities outside Europe become centres of economic power of whole economies and develop disruptive potential. The boundaries between city and countryside are fluid – in huge, sparsely developed urban landscapes just as much as in densely populated towns and cities, which are made "edible" by urban farming. Cities are competing internationally for new industries and talented mobile individuals. On the one hand new urban conglomerates are growing, while on the other hand old mature cities have their advantages: solid culture and quality-of-life.



### Globalisation

When you consider the facts, globalisation is more like good news than a threat – the world, which is moving ever closer together, is becoming a better place. The Internet spans the world and encourages a global culture in its virtual space. If the Connectivity and Globalisation megatrends collide, the result would be friction and disruption. Globally active platform companies without their own infrastructure can become major commercial powers and turn complete industries upside down. The recursion of globalisation: the return of the local and original in new clothes.

---



### Knowledge Culture

This megatrend enters the next dimension – new learning becomes the principle of knowledge culture. The radical changes in industrial and knowledge societies lead to the framing of a cultural question that all of society has to address. Knowledge Culture represents a megatrend that will decide the future viability of individuals, companies and whole national economies. Knowledge is still power, but in future more and more people will have access to this power. The digitalisation of knowledge and education provides the driver for this.

---



### Security

Words beginning with "cyber" change the concept of security and form the basis of the Security megatrend. Official channels can no longer promise security. People are both security risks and at risk themselves. Companies assume more responsibility for their security while the state steps back. New security culture is agile, mobile, flexible and disruptive. It must provide quick answers to the new challenge in the world of cyber-(in) security.

## Global rethinking sets new standards

Global rethinking of our environment and health in the widest sense leads to great changes in almost every industry. The growing need for individuality and authenticity as well as the search for sustainable, environmentally compatible, climate-neutral methods of living and constructing are helping to give new popularity to a material: wood. Its characteristics as a renewable raw material, as a healthy, versatile and flexibly combinable building material, ensure that building and living with wood will become far more widespread. Not least because wood is also gaining popularity for its aesthetic qualities – and not only in Scandinavian forest cabins or quaint Alpine chalets. As a material, wood has all the advantages that are valued today and will be in the future: healthy indoor climate, the high feel-good factor, modern design and an energy-conscious method of construction. All these are the measure of a high quality of life in the eyes of increasing numbers of people.

In the next few years, the wood industry will experience a real boom – driven by the growing consciousness of quality and the desire of many people to enjoy a healthy and sustainable lifestyle. Craftsmen and the wood processing industry can profit enormously from this, if they can successfully drive forward the sustainable exploitation and innovative use of wood. As well as all the good traditions of craftsmanship, wood processing companies will have to align themselves more effectively with current trends, new living concepts and contemporary architectural styles. Because the demand, for example for houses constructed of wood, is less and less determined by a yearning for Alpine idylls and the log cabin ambience. On the contrary: there is an ever-increasing trend towards combining wood with new forms of design and modern architecture.

In future, the naturalness of wood will no longer be contradictory to its contemporary use in innovative technology. On the contrary, the success of the wood processing industry will in future depend far more on

the integration of modern (environmental) technologies and "ambient intelligence". Ambient intelligence focuses on the use and networking of modern information technology (hardware and software), e.g. in the "smart house". Here ambient intelligence can make everyday tasks easier and save energy or improve energy efficiency. The trend embodied by these components may be described as "Slow Architecture" and is considered in more detail later in this study.

Wood is not very often used alone as a building material. Instead of adopting the extreme position of a "wood purist", the approach in future years will be to combine wood with other materials, such as natural stone, glass and concrete, in an intelligent manner.

In future, new applications and innovative uses of wood will not be confined to house construction and the home. Interesting fields of innovation for wood are arising throughout in all urban areas and in transportation architecture. If these various potential uses are considered and realised, new sales markets could be developed for wood as a raw material.



# Wood as a Material

Wood is experiencing a revival in the field of architecture, design and handwork. What are the key factors and challenges facing this growing trend and how can the industry build on it?

Two materials defined 20<sup>th</sup> century architecture – steel and glass. They provided quite literally the backbone for modern western architecture and defined to a large extent our perception and the legacy of our European urban landscape. Concrete and brutalism opened up new vistas and design, but today it is the turn of wood to bring new forms and functions to architecture and new perspectives on how we will live. If you talk to architects and designers you may hear them whisper, "wood is the new concrete". But, because of new technology, innovation and exciting new finishing methods, wood offers far more. Wood, in its many forms and functions, is experiencing a revival, a renaissance. Or as one architect put it, timber architecture is having its moment. In terms of the worldwide building industry, it is however going to be bigger than just a moment – it is a trend that has great potential for the future of our cities, the future of housing, the future of how we will live and – last but not least – the future of the planet.

## Knock on wood

Wood is more than simply a building material, it is also of great cultural and psychological significance. We know that in many cultures throughout the world - from Austria and England, Iran and Egypt

to Romania and Bulgaria - people touch wood for luck or in a superstitious attempt to prevent something bad from happening. We literally try to "knock on wood" and often exclaim "touch wood" at the same time. Failure to find and touch a wooden item can even be considered ominous, and cause consternation and worry in the person involved. The term "tree huggers" has long since entered our language as a term for people close to nature, and as architect Michael Green proudly notes, people sometimes even hug his wooden buildings. If wood is our cultural touchstone - the material we turn to for comfort, for reassurance, and for psychological support and hope - what does this mean for the future of building and living?

When we consider building with wood in any or many of its forms, we are influenced consciously, but more often subconsciously, by biophilia. The biophilia hypothesis suggests that there is an instinctive bond between human beings and other living systems, that we have a deep bond to other forms of life, such as trees. The term was coined by Edward O. Wilson in his book, "Biophilia" (1984), in which he defines biophilia as "the urge to affiliate with other forms of life". It was around this time that Professor Roger S. Ulrich completed one of the first and best-known studies in environmental psychology.



Ulrich's groundbreaking conclusion was that patients recovering from surgery in rooms with a window facing natural surroundings took less medicine for pain relief than patients with a window facing a brick wall. Since then, related research has examined the relationship between trees and the perception of safety in cities, the effect of gardening on the quality of life of people with disabilities, and how the use of wood in interiors can reduce levels of stress in schools. Furthermore, leisurely forest walks are believed to reduce heart rate and blood pressure, decrease sympathetic nerve activity and lower levels of the stress hormone cortisol. It's not surprising then, that there are companies, consultants and councillors who promote such things as "therapy sessions in the forest" as part of a mental and physical healing process.

“Every time people go into my buildings that are constructed of wood, I notice they react completely differently. I've never seen anybody walk into one of my buildings and hug a steel or a concrete column, but I've actually seen that happen in a wooden building.”  
**Michael Green, Architect**

Michael Green points out, “No two pieces of wood can ever be the same anywhere on Earth. That's a wonderful thing. I like to think that wood gives Mother Nature fingerprints in our buildings. It's Mother Nature's fingerprints that make our buildings connect us to nature in the built environment.” Today it is not just psychologists and therapists, but architects and designers who will fiercely defend the belief that humans react



The Wood Innovation and Design Centre in Canada is a showcase project for multi-storey timber construction. It demonstrates how rapid and precise construction can be combined with the comfort and aesthetics of wood.

positively to wood in all its uses and forms, both psychologically and physiologically. As Winston Churchill once said, “we shape our buildings, thereafter they shape us.”

### The good wood

Next time you look at a wooden structure, building or piece of furniture, don't just admire the curves, the grain or the strength, but think of it as a “carbon sink”. Wood is the ultimate sustainable material. It is considered to be a much more sustainable material to build with than concrete and cement because it sequesters carbon dioxide from the atmosphere (one tonne per cubic metre of wood). It is undisputed that forests play a critical role in absorbing carbon dioxide (CO<sub>2</sub>), the primary chemical

compound responsible for the greenhouse effect. However, the subject of greater dispute has been how to reduce emissions – and lock more in – with the aim of reducing global warming. One thing is clear, the recent unilateral agreement in Paris 2015 to reduce worldwide carbon emissions will have a direct effect on the use of wood in its many forms and guises in the building industry.

One of the questions for the future is therefore: how can we harness this recognised ecological advantage of wood for our purposes? And what role could CLT – a technology which is already creating new innovations today – play in future?

# Future Technology

## Cross Laminated Timber



One of the most renowned international architectural magazines, Dezeen, reports on the potential of timber construction and its future. The article quotes British architect Andrew Waugh with the words "This is the beginning of the timber age." Waugh has recognised the advantages of timber construction and goes on to say: "that building in wood is super fast, super accurate, and also makes the most amazingly beautiful spaces", and "These are buildings that feel very good to be in, very robust and very solid."



Building in wood is super fast, super accurate, and also makes the most amazingly beautiful spaces.

**Andrew Waugh, British Architect**

According to another strongly held belief, the key to success for timber construction lies in cross laminated timber technology. London architect Alex de Rijke has worked with this ecological building material for 10 years and goes so far as to describe wood as the new concrete. He thinks that cross laminated timber has many unbeatable advantages over steel and mineral-based building materials. Nevertheless, the future may well lie in the development of hybrid technology, where various building materials with different strong points are combined into a single building system, thereby opening up new architectural possibilities. "This could make wood a more interesting option, even for sceptical designers," says British architect Alex Smith from Hawkins Brown.



## History

Cross laminated timber was first mentioned in specialist literature almost 30 years ago. In 1998, this new type of product was granted its first national technical approvals in the German-speaking countries of Europe. Similar products were already known to the market under names such as blockboard, plywood and laminated veneer lumber (LVL), but the huge innovation here was the sizes in which cross laminated timber (CLT) could be manufactured. One of the possible benefits arising from this is its use as a loadbearing element in structures thereby opening up new perspectives and possible applications to the whole industry. Over the years, the use of solid timber components has become very popular and represents an important addition to the techniques of traditional timber construction.

## Manufacture

Cross laminated timber normally consists of 3 to 7 layers of softwood boards bonded together crosswise. The individual boards are connected to one another longitudinally by finger joints and the layers are glued together. The product is offered in various qualities and grades. Depending on the method of production, the first step is usually to produce single-layer panels by gluing the individual boards together along their narrow edges. These layers of boards are then stacked to form multiple layer panels. The process is highly automated and can provide ready-to-use CLT elements with lengths up to 16 m and widths up to 3.5 m.



## Materials and surfaces

The type of wood normally used is spruce, but other woods notably fir, pine, larch, Swiss pine and Douglas fir are also suitable. While the use of other wood types may, pursuant to the approvals, be used in the loadbearing board layers, wood types not mentioned above are frequently used for the decorative, non-loadbearing covering layers.

## Fields of use

The fields of use of solid timber elements are many and diverse. They are used as structural, stiffening and non-loadbearing walls, ceilings and roofs elements and can be combined with other construction materials. They are used in the construction of detached houses, multi-storey residential buildings, public buildings, administration buildings, industrial and commercial buildings, structural alteration works, bridge building and for adding additional storeys to existing buildings. Design and construction comply with the structural, building physics and legal requirements.



## Building in wood has positive effects for the environment

CO<sub>2</sub> emissions for different materials (in tonnes CO<sub>2</sub>)

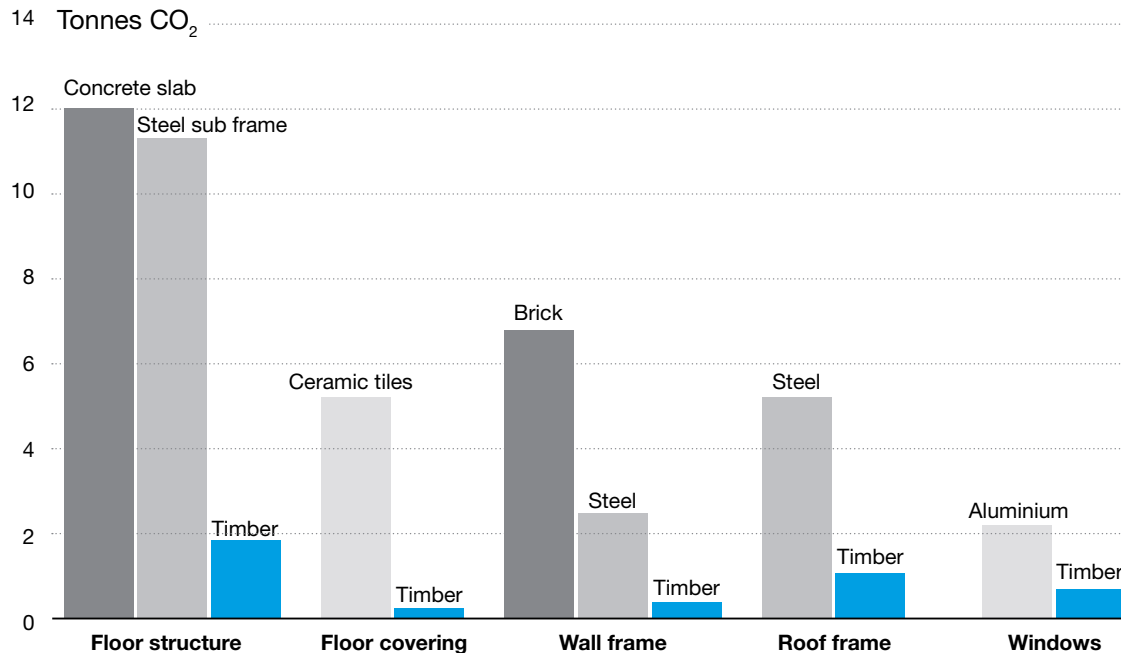

Source: InWood International Magazine, Issue 55, Feb-Mar 2004

### Wood is a CO<sub>2</sub> store

One of the most important ecological advantages of the processing of wood into CLT is that a wide range of quality of tree trunks can be used, in turn fostering a sustainable forestry industry. By harvesting mature trees and then replacing them with saplings, it can be argued that sustainable forestry actually reverses CO<sub>2</sub> emissions. Healthy, growing trees have a negative CO<sub>2</sub> balance.

To maintain a negative carbon balance, old or mature trees have to be harvested and new trees must be planted. The use of trees of differing quality for manufacturing wood products locks CO<sub>2</sub> into the wood. In short, using wood creates a positive effect for the environment which is called a carbon sink. A recent study published in the journal *Carbon Management* encouraged architects to reconsider concrete and steel materials and instead use sustainably harvested wood to reduce the amount of carbon dioxide associated with construction. According to

the results of the study, if builders use more wooden structures, the amount of carbon locked up in construction materials could be quadrupled within the next century, "Every time you see a wood building, it's a storehouse of carbon from the forest," said Bruce Lippke, professor emeritus of forests resources at the University of Washington, and lead author of the paper on Carbon Management that pulled together studies on the environmental impact of wood, concrete, steel, and other building materials. "When you see steel or concrete, you're seeing the emissions of carbon dioxide that had to go into the atmosphere for those structures to go up," he said.

Along with his co-authors from the University of Washington, Mid Sweden University, and the U.S. Forest Service, they considered the entire lifecycle of the building materials, including things like the gas used to truck logs out of the forest and the energy used to fuel concrete factories. They also considered the amount of carbon dioxide sequestered, or stored, by the building materials. One of

the important conclusions was that we need to look at the whole cycle realistically – and not just romantically – as is often the case when dealing with issues surrounding wood and ecology.

“There’s really no way to make these comparisons – and get the right answer for carbon mitigation – without doing life cycle analysis,” Lippke said. The production of steel and concrete needs tremendous amounts of energy and releases greenhouse gases. They effectively cause a one-way flow of carbon dioxide, as lots of the gas gets released and none of it gets sucked back up. For example, if you replace a steel floor structure with one made from a wood-based material such as CLT, you can reduce the carbon footprint by almost 10 tonnes of carbon dioxide for every tonne of wood used. In another example, the use of timber elements instead of reinforced concrete slabs can reduce the amount of carbon dioxide by about 3.5 tonnes per tonne of wood used.

By making and purchasing things made from wood products such as CLT, we minimise the need for products that are manufactured from carbon-emitting steel, concrete or plastic. However, education is one of the keys to unlocking the potential of a using more wood in the building process. One of the mantras of the ecological movement was always to “save the forests”. In fact, they may well “save” us, but in a different way to how we think.

Educating (or better put, informing) the general population and craftsmen, architects and planners about the benefits of working and building with wood is a great challenge. Other – and possibly less well-known – advantages include superior properties relating to fire protection, earthquakes and thermal insulation, which can make living in a timber house safer and more comfortable.

## Timber and CLT reach new heights

Imagine a forest. Then picture an architect in that forest. An architect like Michael Green who, when he looks at trees, doesn’t see height in terms of metres, but in “floors” of a

building. “Look at the height of the trees” he says, “I live in Vancouver, near a forest that grows to 33 stories tall. Down the coast here in California, the redwood forest grows to 40 stories tall. But the buildings that we think about in wood are only four stories tall in most places on Earth.”

The argument goes, if trees can grow so tall and strong, why can’t we build that tall or even taller? The fact is that outdated building regulations are inhibiting the construction of taller wooden structures in many countries. There are exceptions, and the possibilities and potential are changing – slowly but surely – thanks to architects such as Waugh Thistleton, who are behind some of the most pioneering timber structures that have emerged in the last few years. His emphasis is on sustainable buildings, and his company was one the first to test the capacities timber had for going tall.



Murray Grove in London

Their first pilot project was **Murray Grove** (see above), a nine-storey, 30-metre-tall, timber building in Hackney, London. Made entirely out of wood – from the structure, walls and floors to the lift cores and staircases. It was completed in 2008, and at the time was the tallest timber structure in the world. Currently, the company is at working on a ten-storey, 123-unit timber structure in London.

“For an architect, the appearance of a building is absolutely crucial. Wood offers enormous possibilities for high-quality design. **Franz Lattke, Architect**”

The pioneering project in **Dalston Lane** will be a record-breaking cross laminated timber (CLT) residential structure incorporating a huge proportion of this material. Interestingly, the London Borough of Hackney, where the building will be located, actively encourages timber construction, mooting a 'timber first' policy in 2012. This building will join a number of other timber buildings in the area, making this central London borough a world leader in timber construction. The Dalston Lane building, which incorporates more than 3,000 m<sup>3</sup> of wood, is one of the world's latest showcase projects. Its construction will create more than 12,500 m<sup>2</sup> of residential and 3,460 m<sup>2</sup> of commercial floor space. From an environmental point of view it will be considered as 'carbon negative'. CLT experts have calculated that the building will save 2,400 tonnes of carbon, compared to an equivalent block with a concrete frame. By using CLT construction, the embodied carbon is 2.5 times less than that of an equivalent concrete frame. At 10 storeys high the structure is surpassed in height by just one 14-storey glued laminated timber (Glulam) and CLT hybrid structure in Bergen, Norway. Upholding its material integrity, Dalston Lane's external, party and core walls, floors and stairs will be made entirely of CLT.

No less inspiring are Australian developer Lendlease's 10-storey pure CLT apartment block – known as **Forte**. This was constructed in 2012 in Melbourne's Victoria Harbour, taking five skilled labourers a mere ten weeks to construct. Another leading flagship project for CLT is the The Wood Innovation and Design Centre in Prince George, British Columbia. Designed by a practice called MGA the eight-storey building shows the potential for mid-rise and high-rise structures made out of engineered timber. The design uses a hybrid of glulam columns and beams with CLT floors and mass timber walls, and is easily repeatable. It is important to note that pure timber advocates say hybrid construction techniques that use concrete or steel are unnecessary and believe that one can build to at least 25 storeys in pure timber.

Testing this belief is **HoHo** (see below), a 24-storey, 84-metre-high building, which is set to be the the world's tallest timber structure, built in Vienna.

The Wood  
Innovation and  
Design Centre  
in Canada



**HoHo (HochHolzHaus or "timber high-rise") Vienna**

As well as conceptually, visually it will also send a clear signal - as the construction is intended to remind you from the outside of huge wooden blocks with a facade reminiscent of tree bark. Naturalness and, above all, the exposed wood surfaces in the interior are also part of the underlying idea of making wood in this high-rise a perceptible experience. Approximately 75% of the building from the ground floor up will



Photo: Photography by Emma Peter

be made of wood; the service core will be constructed of solid reinforced concrete to which the timber supporting structure is secured. Furthermore, according to HoHo, “the modular office format permits later individual changes that can be modified at any time without much effort. This flexible arrangement of the floor plan additionally ensures that the high-rise will never lose its allure for tenants, because it guarantees a very long life span in a friendly atmosphere.”

Last but not least, HoHo Vienna will be built according to the criteria of the new TQB assessment system (total quality building) developed by the Austrian Sustainable Building Council (ÖGNB). The energy concept will include measures for the prevention of energy loss such as lifts equipped with energy recovery technology, photovoltaic systems, air/water collectors for the pool, fundament absorbers as well as a decentralised ventilation system with air-conditioning.



Photo: LifeCycle Tower One, Aarmpati, Wiki Commons, CC BY-SA 3.0.

#### LifeCycle Tower ONE in Dornbirn

Other key projects that are leading the way with wood promotion include Zumtobel’s **LifeCycle Tower ONE** in Dornbirn, Austria (see above), which claims to be the world’s first unencapsulated timber hybrid high-rise building and to set new standards in respect of sustainability, efficient use of resources and quality of life.

The 24-storey timber high-rise (HoHo) in Vienna will be the highest timber structure in the world: approximately 75% of the building above the ground floor will consist of wood.



## A growing profile for CLT

Many high profile architects and developers are in agreement, that the 21st century will be the time for timber. Big efforts to raise the profile of CLT for building have come from the US Department of Agriculture in a joint effort with the private sector that it hopes will improve the functioning of an entire CLT supply chain. Washington State University has received a grant from the U.S. to develop a system by which architects, for example, might be able to send their CAD/CAM designs to a CLT manufacturer and have those designs seamlessly transferred into the software. This then tells numerically controlled machines where and how to cut the CLT panels.

“It’s about using advanced manufacturing to get beyond just thick, dumb panels and put in functionality,” says Todd Beyreuther, an assistant research professor at WSU’s Institute for Sustainable Design. Where today manufacturers use a subtracting process, first building the panels and then cutting out windows and doors – a process that wastes wood – an advanced manufacturing plant would use an additive process, such as a 3-D printer. This puts wood only where it is needed, leaving voids for doors, windows, plumbing, mechanical and electrical lines. The machines could install various materials in LEGO-like fashion between the sheets to add soundproofing, fire resistance and other capabilities. He points out, “Architects would be able to

use all the technology at their disposal to customise materials to their specific needs. It's about asking the wood [panel] to perform many functions with engineering and technology. The premise is that architects already think that way."

” CLT really is a dream material. It is one of our favourite materials; it's made from a renewable resource, it sequesters carbon dioxide, it's lighter than concrete and it's lovely to look at. What's not to love? **Lloyd Alter, Treehugger.com**

WSU is working with several companies including Vaagan Brothers Lumber, a technologically advanced Colville-based sawmill and logging company; Spokane Valley's Berg Manufacturing, which has capabilities for installing plumbing and electricity in containers used for camping; and SmartLam Technologies, a Montana-based CLT manufacturer. The goal is to build a pilot manufacturing facility to advance the state of the CLT manufacturing art. As Andy Barrett of Berg points out, "Ideally, you would put timber in one end and get [smart] panels with the plumbing and electricity already installed at the other end." It would represent a great time and cost saving on site as the electricity and plumbing would be connected at the same time the panels are bolted together at the construction site. While the potential and motivation for cross-industry innovation is high, the challenge at the moment, however, is still to make it cost effective and competitive.

The potential for CLT will thus not only depend on cross innovation, on the shifting views of the eco-aware community, on increasing awareness and support for this innovative material but also on the skills and determination of architects and city planners around the world who are pushing the boundaries of how we will live in the future.

# Wood as the Material of the Future:



– Sustainable

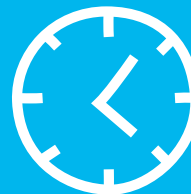

– Quick to build

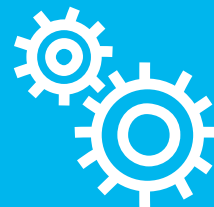

– Efficient

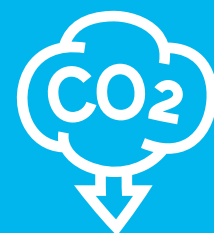

– Climate-positive

# Future Potential

---

## Ecological building materials

There is no doubt that the use of renewable raw materials makes a contribution to climate protection. However, a new development is the consideration of the building material's lifecycle – consisting of its manufacture, use and disposal – which is then included in the official lifecycle analysis of buildings and supplies a direct statement of a building's ecological quality. The objective is to foster a consciousness of the use of ecological materials and to promote their use. Wood is a model material that can make an exemplary contribution.



---

## Building systems thinking

Building with wood is becoming more popular because of its wide range of advantages. The crucial advantage arises from an increasing degree of prefabrication in timber construction and the resulting technical possibilities this offers. However, this will place demands on timber construction companies to develop at a faster pace than they have in the past and test the limited creativity and design versatility of engineers and architects, which is evidenced by the prefabricated concrete panel structures of the 1980s. However, myriad completed timber construction projects – characterised by the individuality and flexibility of building in wood – show that current developments in this area have improved. The increasing demand for timber structures should motivate companies to shift their focus from the manufacture of uniform, standard modules and take the necessary steps to develop comprehensive, smart building systems in order to be able to react to the future needs of their customers. From the point of view of research and development, many believe this situation may be overcome only by architects, engineers and industry working closely together.





---

## Individualised digital prefabrication

Nowadays, when we speak of aesthetically pleasing buildings of the kind that amaze and bring out the feel-good factor, the discussion among experts is about the successful synthesis of technology and spatial form. The skill is to deploy construction technology in such a way that it integrates into the overall architecture yet still fulfils its function. The origin of the term tectonics lies in timber construction and the concept continues to shape the architecture of the present and future. Three important differences distinguish the tectonics of buildings, namely the material used, the method of production and the design. Through the continuous development of wood as a material and the use of computers in design and manufacture, designers have access to previously unheard of possibilities in the technical implementation and design of future buildings. The efficient manufacture of individual components is equally the result of digitally controlled manufacture, which fosters the megatrend of increasing individualisation.



---

## Uncomplicated flexible revitalisation

One of the greatest potentials for the use of wood is the revitalisation of buildings in rural and urban areas. Reasons why existing buildings may need to be modernised to meet the requirements of the 21st century include wear and tear affecting their appearance, changes in living or working habits or unacceptably high energy consumption. Or it may be that there is hardly any space for new buildings, for example, in the centre of conurbations and hence any remaining areas need to be developed to greater occupation density, which opens the way to new business fields in urban construction. Building in wood is quick, uncomplicated and precise, which, added to the low weight of this renewable building material, provides compelling arguments in favour of its use over conventional building methods.



# The Massive Wood Market

Building with solid wood elements (CLT) is a success story. Hardly any other building product in recent history could show this sort of growth at times of financial crisis (banks, Greece, refugees...), in which the whole construction sector is under pressure and struggling against shrinking markets. The tripling of the market volume from 200,000 cubic metres in 2008 to over 600,000 cubic metres in 2015 has never been seen before.

A great product in line with the current zeitgeist is attracting a lot of interest with this dynamic development in Europe and is set to take over the world. New production facilities are said to be springing up worldwide. In addition to developments in Europe, large investments are also being made in North America and Australia. Japan could also develop into an interesting cross laminated timber market within the next five years. The 2020 Olympic Games may prove to be a catalyst here. Against this backdrop, it can be only a matter of time until we reach the magical mark of 1,000,000 cubic metres of solid wood elements manufactured in a year.

In addition to geographic growth, the established markets in Central Europe are also expected to show growth in future. A falling market in detached houses will still grow slightly due to wood substituting for established building materials such as concrete and brick. The continual increase in product recognition will contribute to these developments.

The growth driver in the established markets will undoubtedly be multi-storey residential buildings. The 3- to 6-storey building market should be given particular mention here. This sector has seen the greatest degree of structural research and CLT has proven itself to be a functioning building system in innumerable projects. The short construction time and associated lower financing periods, together with the usable space gained through thinner wall construction, are also powerful arguments for the future. Soft facts such as ecological construction and lower noise and dust nuisance for the construction site neighbours are becoming increasingly important.

The showcase projects are also worth mentioning. At the moment we are in the middle of a height race. 13, 17, 24 and even 30-storey projects are currently at the planning or design stage. These

projects will contribute to future growth simply because of their size alone. However, the fact that these eye-catching buildings draw attention across the industry to construction using solid timber elements and also offer the perfect showcase for the capabilities of timber construction, appears far more important. The 17-storey lighthouse project in Paris ultimately also serves to build trust for the future investor in a 4-storey residential complex in a suburb of Graz, reinforcing his decision and motivating him to plan further projects in wood.

I am looking into a positive future. However, we must not allow ourselves to feel overconfident. We still have a lot of work to do. Continuous product development and the design of systems solutions to mention just two. We are a long way from achieving our objectives in this area and can learn a lot from other parts of the construction industry. The equal treatment of wood alongside other building materials is also something we must strenuously pursue. Timber is often at a disadvantage compared with other materials due to regulatory requirements, which is another area where we must find some general solutions.

For the future, we must look to combining our efforts within the industry on research and development and work together with universities to drive forward continuous product development. With all these provisions in place, we can confidently continue on our path and take forward the story of success outlined in the opening paragraph.



Photo: Stefan Erling

**Gernot Weiß**  
**Sales Director CLT**  
 Bad St. Leonhard,  
 May 2017



# Global Market Potential of CLT



**Bridport House, London**  
8 storeys: The highest building in London built using CLT was erected in only 12 weeks.



**The Wood Innovation and Design Centre** in Canada will be the highest timber building in North America.

-  **Established market**
-  **Developing market**

Sales

Development period

First technical approval for the product

200,000 m<sup>3</sup>

1998

2008

Source: timber-online.net, dezeen.com. Data for 2008: Based on information published in the Holzkurier

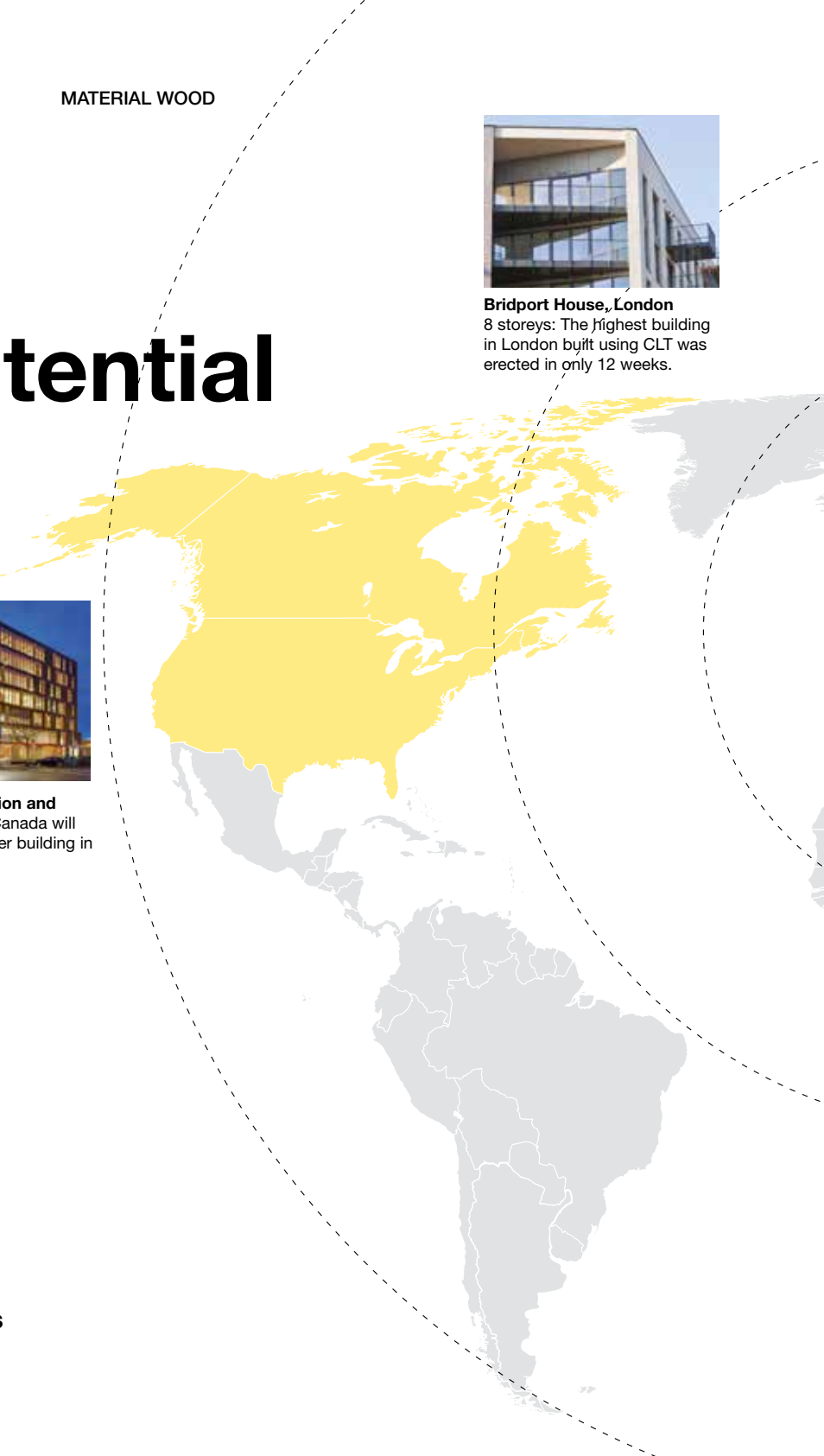

Image sources: Wood Innovation and Design Centre: Photography by Ema Peter; HoHo Wien: cetus Baudevelopment GmbH; Timber Tower: Wiki Commons, Gerd Fahrenhorst, CC BY; Murray Grove: Wiki Commons, Waugh Thistleton Architects, CC BY-SA 4.0.; Bridport House, Arctic Observatory, Student Halls of Residence Trondheim, Wood City, Library at the Dock: Stora Enso.

**Arctic Observatory, Norway:** prefabricated for safe and above all quick construction



**Student Halls of Residence Trondheim, Norway**



**Via Cenni Milan, Italy's tallest CLT multi-storey building complex**



**The Timber Tower in Hanover becomes the first wind turbine structure made from CLT**



**Murray Grove, first 9-storey CLT building in London**



**HoHo, HolzHochhaus Vienna:** a 24-storey, 84-metre high building, which will be the highest timber structure in the world

CLT production in USA, Finland and Japan planned

**Library at the Dock in Melbourne, the first public CLT building in Australia**



60% Austria  
16% Germany  
24% Rest of the world

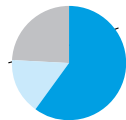

620,000 m<sup>3</sup>

Market period

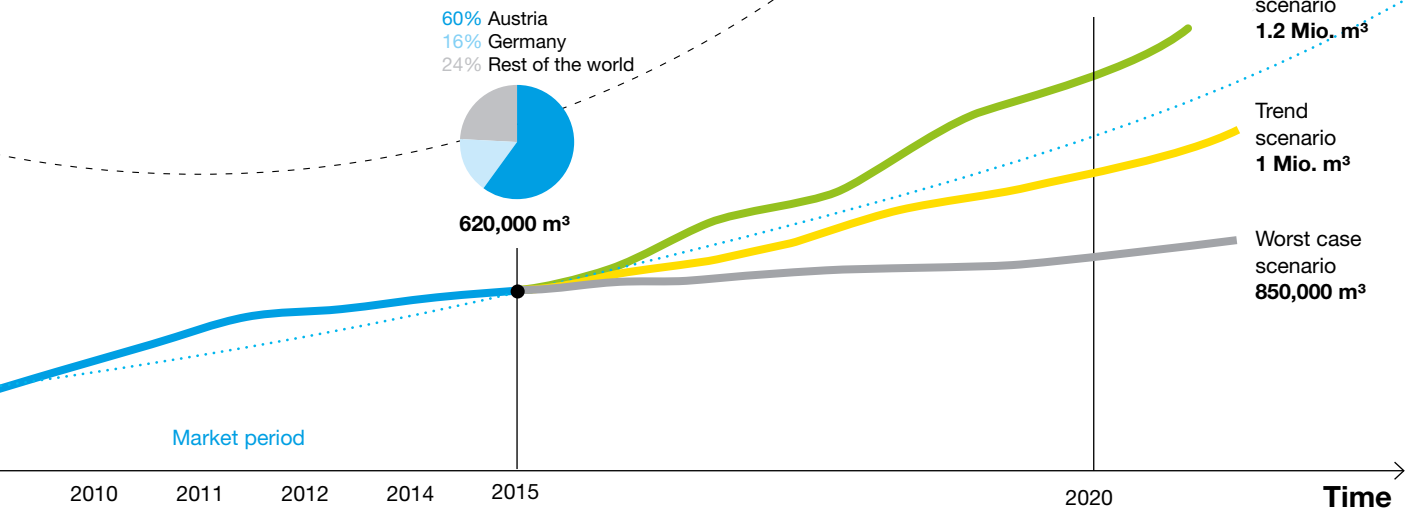

Best case scenario  
1.2 Mio. m<sup>3</sup>

Trend scenario  
1 Mio. m<sup>3</sup>

Worst case scenario  
850,000 m<sup>3</sup>

Time



# From Space to Place: Urbanisation on the Rise

How will the cities of the future look? What will be the shape and feel of our increasingly urbanised landscape? And what role can wood play in the face of increasingly complex demands on urban architecture?



I believe that cities, where the thought of timber construction has not been entertained for a long time, will come to the conclusion that wood also has qualities to offer.

**Helmut Dietrich, Architect**

Urbanisation has long been considered very much a negative term, associated with phrases like “concrete jungle” and “urban decay”. Today that image is changing fast, and we are moving towards a more positive image of our urban landscape thanks to innovative architecture, bold city planners, innovative mayors and new thinking about materials and space. Cities are repositioning themselves, marketing themselves as creative hubs, as architecturally adventurous, socially conscious and above all with superior ecological credentials. And where once we associated wooden construction primarily with rural farming areas and country

dwelling, the benefits of wood in building are becoming ever more relevant to the demands of today’s complex cityscapes. The revival and of wood in building and design has the potential to improve the lives of the current and future inhabitants as well as their relationships with their urban environment.

## **A state of mind over matter**

If we look at the worldwide development of cities we are confronted with a scenario where we expect at least 75% of the world’s population to be living in an urban landscape by the year 2020. This is an increase from 10% in the year 1900, and 50% in 2007. But we should not forget that, as the famous sociologist Robert E. Park said in 1914, the city is a state of mind. Even those who do not live directly in the city are under the influence of it either economically, in terms of family and friends living there or just because of the fact that they will rely on it for such things

as possibly schools, services, or simply for shopping or entertainment.

Urbanisation, is for the majority of people good news, although we are conditioned to think of it in negative terms. People in cities are better off, but there is a problem which the architect Alejandro Aravena called the “3S” menace. Winner of the 2016 Pritzker Prize, Aravena points out that the scale, speed, and scarcity of means with which we will have to respond to this phenomenon has no precedence in history. In a TED talk he highlights the point that “of the three billion people living in cities today, one billion are living below the poverty line. By 2030, of the five billion people that will be living in cities, two billion will be living below the poverty line. This means that we will have to build a one million-person city per week with a budget of 10,000 dollars per family over the next 15 years. If we don’t solve this equation, it will not mean that people will stop coming to cities. They will come anyhow, but they will live in slums, favelas and informal settlements.” For many cities and situations this will mean using materials that are easily and quickly pre-fabricated and ecological, such as CLT, and flexible floorpanels that can adapt to changing populations and family situations.

“The city is a state of mind, a body of customs and traditions, and of organised attitudes and sentiments that inhere in this tradition. The city is not, in other words, merely a physical mechanism and an artificial construction. It is involved in the vital processes of the people who compose it, it is a product of nature and particularly of human nature.”  
**Robert E. Park, Sociologist**

As cities grow and increasingly influence our lives we also need a way to measure them, not just in terms of population quantity and density but in terms of quality. The Danish poet Soren Ulrik Thomsen once said a well-functioning city needs 3 key qualities: it should be complex, chaotic and colossal. But which criteria should we use to evaluate our cities? According to the World Health Organisation, we also, particularly in the western world, need age-friendly cities.

The ageing population is one of the biggest challenges our society will face in the future in terms of health and the economy.



#### Trend: Age-friendliness

Research has shown that old people are more likely to be happy if they go out, participate in local life and interact socially. Cities are an inhospitable place for the elderly and many suffer under so-called “self-imposed house arrest”. Busy streets, poor lighting, lack of public amenities, and an unfriendly environment has a huge impact on self-confidence, mobility and well being. So what is the role of the “material world” in this scenario - and how can wood improve the lives of older people? Many of the initiatives of the over 250 cities that have so far signed up to the age-friendly city scheme are low-level micro-changes. Manchester city has introduced a take-a-seat initiative - wooden chairs given to local shops so people can sit down. Park benches with warm-to-touch material (wood) and higher arm rests that enable easy standing up, public park gyms, age-friendly gardens (no steps), and shelters and seats at bus stops. As one of the participants pointed out, it is not about the grand gesture, but the small things that encourage fitness, social interaction, mobility and participation in life outside of the home. And the small details such as the materials that can make all the difference to quality of life.

It is not only the older population, but also increasing singlisation that forms part of what we identify as the megatrend of individualisation. This is a big challenge to



## Age-friendly cities

Issues relevant to a city of the future

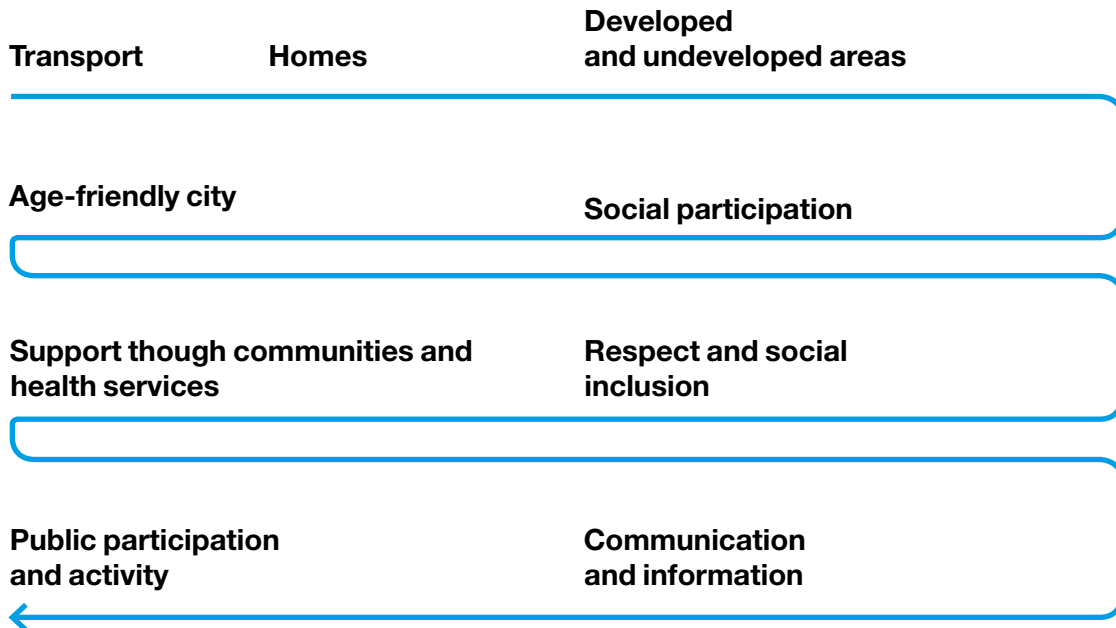

building for the future. Many cities are already hosting an estimated 50% single households, and others are expected to reach this in the near future. This too, especially in combination with an ageing population, will have a huge impact on how we will live and build in the future.

gardening, co-entertaining or co-fitness, is all part of the move towards optimising our investment in our living space. A shared space is a personal space saved. If you can share say a fitness room, or even a large kitchen when you need one, you don't need to have one in your apartment or house.

## New body of urban architecture

As the population density and cost of living increase in cities, we are seeing a distinctive and continuing trend towards a functional reduction of living space – but this is taking place with maximum effectivity. This means that we are moving towards reducing the square metres of space that we need to live in personally and outsourcing functions such as workspace, library, relaxing and cooking to a communal sphere. This is variously called club-style living, a concierge concept, or less simply, communal individualistic living spaces. In future, the demand for living space will be determined not by square metres but by the quota of the shared spaces. One can see this as part of the societal trend in reaction to individualisation - the so-called shift from the me-revolution to a we-revolution. The co-phenomena, be it co-working, co-



**Trend: Co-Living**

The famous architect Le Corbusier once said, “a house is a machine for living in”, and in many ways the optimised spaces of new schemes, such as the housing scheme by Adapt/N architects in New York, confirm

this. Proposals for his micro housing puts the ideal size for one-person developments at 25-30m<sup>2</sup>. Being America, they have a large fridge but no oven – with a microwave instead. But the key selling points are the places to socialise outside the units: gyms, communal spaces and roof decks.

Another of the key related trends we see in the current urbanisation is modularisation - the pre-fabricated homes or apartment blocks that can be pre-formed and put up quickly, quietly and efficiently. A boost to the somewhat negative image of pre-fabs is a new design platform launched at the end of 2015. The company Revolution Precrafted commissions star-architects such as the likes of Zaha Hadid, Ron Arad and Daniel Libeskind to design limited edition pre-fabricated pavilions and homes for between \$50,000 and \$500,000. The company's founder, Robbie Antonio, plans to unveil a new prefabricated design every few months. Of the concept he says, "I wanted to change the game of real estate." One of the first designs to be unveiled is curvy wood furniture by Hadid of which he says, "It's what prêt-à-porter is for haute couture." With low construction costs and short build times he hopes to democratise designer houses, making aspirational architecture more affordable and collectable.



#### Trend: Modular Living

In terms of the urban trend towards prefabrication and modularisation, CLT offers distinct advantages for building interiors, houses, offices or public spaces where time

and money are at a premium. As architect Helmut Dietrich points out: "When adding storeys and using roof spaces, it is essential that only lightweight structures are placed on an existing building. Even for urban buildings, wood has the great advantage that it can be incorporated with very little interference with the surrounding environment, because it is easy to prefabricate and the dust and noise exposure on site is very low."

Another issue in cities, alongside space limitations and challenges for building, is the issue of noise pollution on building sites. This is generally underestimated or neglected due to the pressure of time and cost, but is the problem associated with building that is most acutely felt by local residents and workers. When it comes to building with prefabricated CLT, it is well known that CLT construction sites have a reputation for being happy, productive places. Andrew Waugh, founding partner of London-based architecture practice Waugh Thistleton, who has been working with prefabricated CLT panels for 15 years. He believes it has unparalleled advantages when it comes to disturbance of the urban environment: "CLT construction sites are clean, quiet and dry with no site waste, cement mixers, hammer drills or lorries constantly turning up on site."

In addition to the acoustic advantage, Rainer Loos of Wiener Infrastruktur Projekt GmbH points out that "Wood is also recognised for its very high structural qualities. On the one hand, each separate module can be precisely designed and manufactured in the production hall. Furthermore, longevity is achieved through the modular approach. The building can be extended to provide further additional space at any time."

Thinking socially is an increasingly important aspect in the building industry. It is an issue with which companies can significantly boost their image with creative and sometimes relatively small effort and input. Although it was a surprise, it is perhaps no coincidence that the recent recipients of the 2015 Turner Art prize in the UK was a direct action collective of 18 people. Assemble, call themselves, "sort of architects, sort of not", and their urban regeneration project in Toxteth, Liverpool is a ground-up approach to regeneration, city planning and



Eden Home by Marcel Wanders is a prefabricated house that manages to combine luxury, designer style and functionality

Photo: Courtesy of Revolution Prefab Ltd

development, with the aim of using art and design to improve the lives of the residents. About nine Granby Street residents have been trained and employed in a workshop which makes handmade products from demolition waste and construction rubble. When items are sold, the money is ploughed back into the project. For £15 people have been able to buy a door handle made from sawdust, there are pairs of Granby rock bookends at £40, while £150 will buy a pressed terracotta lampshade.

The lesson to be learnt is that a successful urban architecture is about interconnectivity, multidisciplinary and new thinking and about materials and their use. As one of the Assemble group points out “The more we talk about it, the more we realise our practice is incredibly similar to artists and designers. The labels aren’t as important as the works.”



Buildings are just a detail.  
**Torben Schønherr, Danish  
 Landscape Architect**

## From the urban jungle to the urban forest

There is a strange paradox about city living - while there is less green in terms of trees and plants in a city than in the countryside, city living is actually more ecological than living in the countryside in terms of CO<sub>2</sub> production. We can think about the urban forest in terms of bringing more wooden constructions in the city (see the Material World chapter) but we also need to think more literally in terms of bringing more wood into the cities.

If we consider cities to be simply another form of landscape - from the point of view of urban landscape designers such as Torben Schønherr from Denmark - you get another perspective on architecture, life and the potential impact of wood, both in its natural form and as a material in the cityscape. From this perspective, the focus of landscape designers and cities planners is primarily on the human experience at street level. It is about the public space, how we interact with it, and how different use of space



Aarhus Wood Project

and materials can enhance or diminish our experience of it. It is about how it makes us feel.



Breathe Austria, Expo 2015, Milan

The idea of the urban jungle is a construct, a pre-conditioned idea and effectively an old concrete-led era that we are rapidly and thankfully moving away from. In contrast, the concept of the urban forest can bring a new idea and impetus to the city landscape and experience. Bringing the forest to the city can take many forms - from the increased use of wood in building (such as the HoHo in Vienna) to actual forests such as that in the city of Aarhus. The latter, a bold urban landscaping project from Danish Architects Schønherr, involved literally creating a forest in the middle of the city for the summer

of 2012. It was a huge undertaking that connected two city parks to show what can be achieved by letting green spaces take preference and planning our cities accordingly. The project created a green breathing space between the cultural and administrative centres of the city, resulting in a large green communal recreation area for the summer of 2012. The park severed one of the city's main transport arteries because no alternative route could be provided using practical traffic "solutions", thereby creating a huge debate in the process. Many of the project's detractors ultimately wanted it to remain or be repeated.

The clear, unambiguous statement that architecture and landscape are inseparable was also the cornerstone of Klaus Loenhardt's award winning project for the Austrian Pavillion at Expo 2015 in Milan (see above). As Loenhardt, a landscape designer and architect, says, "In this statement we are giving voice to what is apparently a self-evident truth, since architecture and landscape are the materials from which our environment is made. In this context, landscape is omnipresent and is seen as a "natural part" of the spaces we live in. But when you take a closer look, it becomes exciting.

# Conclusion

When we talk about the city we often use analogies with the body: the heart of the city (the centre), the life blood (what makes it tick), the arteries (roads/transportation). We see the city as a living body that needs to be kept healthy - much in the same way we talk about our own bodies and even trees and forests. So how should we build healthy, happy cities in the future?

If we can define a trend or megatrend, such as urbanisation, we can in most cases also identify an anti- or counter trend. This is known as the phenomena of recursion. This occurs when the stresses on that trend are such that it creates a counter reaction. However, it does not mean that one negates or destroys the other - more that it will compliment it or balance it out in some form or another. In the case of urbanisation, it is not just the move to the suburbs and the countryside that we can identify as a recursion, but also of the re-greening of our urban landscape - reclaiming the urban jungle and integrating it with the concept of the urban forest or increased landscaping awareness.

For the future health of our cities and our planet, we need to think not just in terms of age-friendly cities, resilient cities and ecological cities, but above all in terms of mindful cities (see Mindfulness trend). The aim of mindfulness in this context is to achieve a holistic vision of the city, whereby cities approach design, building and planning of the urban landscape through a careful choice of mindful materials such as CLT and wood. As Alejandro Aravena, the winner of the 2016 Pritzker prize, points out, “design's power of synthesis is just an attempt to put at the innermost core of architecture the force of life.” Just like wood.

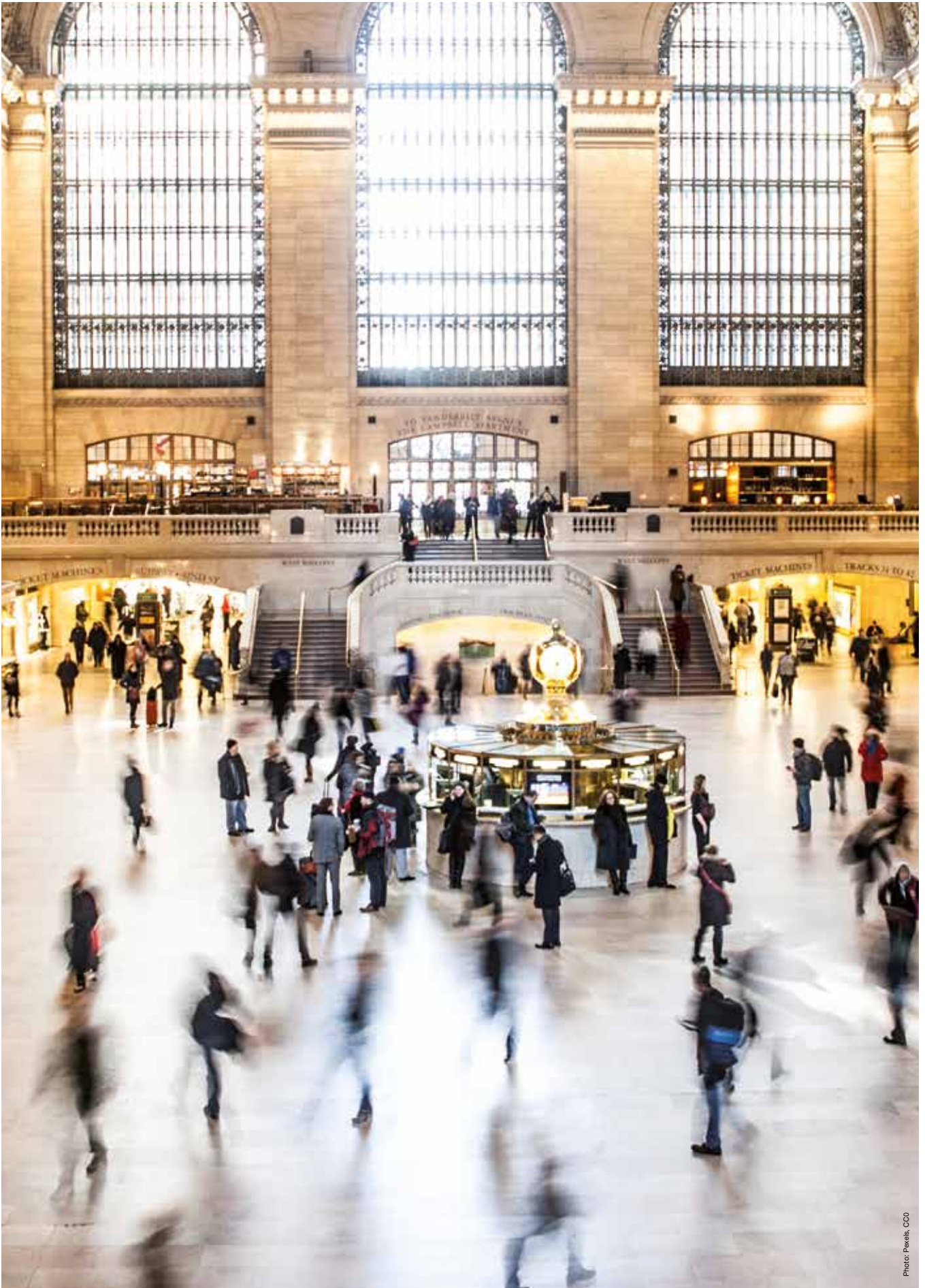

Photo: Pixels, CCO

# Changing Demographics

How is our society fundamentally changing as we move further into the 21st century? As we face the challenges of a new era, how do we address the demographic changes not just of an ageing society, but in an increasingly female-dominated one in which there are ever more singles? What does this mean for how we and the next generation will live?

Demographics, water, food, energy, global health, women's empowerment - these issues are all intertwined. We cannot look at one strand in isolation. Instead, we must examine how these strands are woven together.  
**Ban Ki-moon, Secretary General of the United Nations**

Understanding the fundamentals of the big shifts in our society begins with looking at changing demographics. What for example are the influences of an ageing society on our daily life? How do the shifting gender roles change our working and living environment? Coupled with an increasing amount of single households, the two big megatrends Silver Society and Gender Shift are affecting not just the way we live, but where and how we live. Not only is life expectancy increasing worldwide, but we are becoming "older" much later and more reluctantly than our predecessors. Instead of retiring quietly, the new older generation - the so-called free-

agers - are more active - working longer, studying again, living with other generations and playing an increasingly active part in all walks of society. More highly qualified and higher-earning women in the workforce today will also be a challenge for many industries - not least the traditionally male-dominated world of architecture and construction. Furthermore, the so-called Generation Y - the millennials - are facing very different living challenges to those of their baby-boomer parents.

## From old-aging to pro-aging

You can knit a sweater by the fireside,  
 Sunday mornings, go for a ride.  
 Doing the garden, digging the weeds,  
 Who could ask for more?  
 Will you still need me, will you still feed me  
 When I'm sixty-four?

The generation that grew up with the Beatles song, "When im Sixty Four" lived in

## Becoming old, remaining healthy

Healthy years of life (men) compared to years of life with an age-related disability

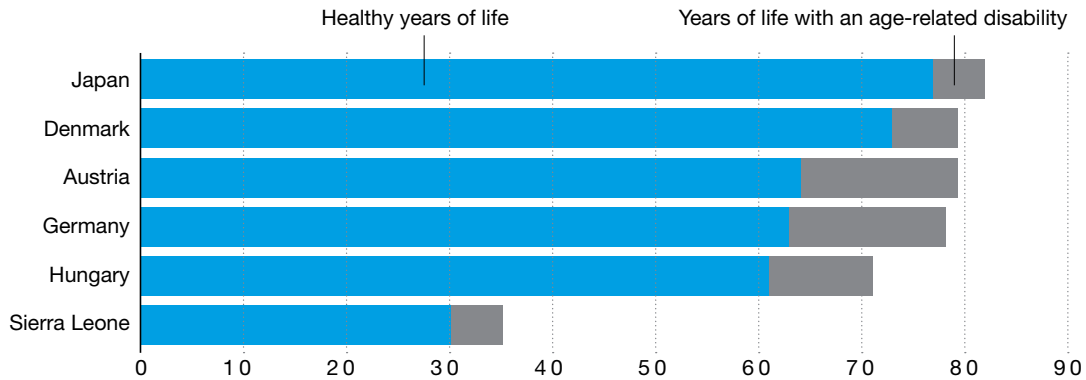

Source: Prof. Carol Jagger, The Lancet

expectation that, by that age, they would - just like their parents' generation - be retired and sitting knitting by the fireside. However, with a vitality that defies those predictions, they find themselves still working, still active, still attractive and still very much “needed” by society. As such we don't call it old-aging anymore - but pro-aging, reflecting the fact that the older generation have a vitality, the advantage of experience, and contribute uniquely to society.

The spike in birth rates during the postwar years means that the Boomer generation represents a disproportionate amount of the population and has been one of the biggest agents of social change. But as this group ages, what will its effect on our cities be and what will this generation need from the places they live as they get older?

This “revolution” in human longevity will impact our cities in many ways. Boomers have not moved, as expected exclusively to rural retirement communities, often preferring instead to remain for as long as they are able in their urban neighbourhoods—where they can continue to lead active lives and mix with other generations (see the chapter From Space to Place). Not only is this reflected in the WHO movement to promote age-friendly cities with a range of strategies from design to development, but in the rise of multi-generational housing complexes, age-mix shared living spaces and co-housing

schemes. Other interesting projects include those in the UK, for instance, where many older people who find themselves living in accommodation that is too large and unmanageable for them alone (following the children moving out or a partner leaving or dying) are renting spare rooms to younger people for a fair rent in return for help with shopping, organisation or simply just for the company. Interestingly, researchers found it was much more a win-win situation than anticipated, with the younger lodgers benefiting from the interaction with the free-agers.

One of the key discussion themes relating to the challenge of an ageing society and how we will live in our homes, is to what extent we will require so-called assisted living, or need to plan for it. Because we are living longer, we are also living with health handicaps for longer than our predecessors. In response, technology companies worldwide are busily engineering a future of electronic devices and robots that claim to offer smart healthcare for the elderly in their own homes. Floors with sensors that “notice” when someone falls and needs medical help, cuddly toys that remind you to take your tablets, robot butlers that can bring you your dinner, or so-called robo-coaches that accompany you during your morning exercises, as is the case in old people's homes in Singapore. But does this vision of smart care and smart houses really solve the problems we face? Do these high-



tech homes offer a place we want to get old, both in terms of design aesthetics, and emotional impact. Does the building industry push these solutions to the detriment of our emotional health?

Writer and researcher Evgeny Morozov is sceptical as to the real human benefits and brings us to think about the long-term implications of such technological utopianism. As he points out, “Wouldn’t it be ironic if technology companies, keen to make our lives longer, also end up making them more miserable? After all, could spending your last years in the company of a seemingly funny robot – it has a joke for every occasion! – be as gratifying as technology companies claim... Thus, while robots might one day make funnier jokes than their human caretakers, it’s clear that they do not in any reasonable way care about the patients they serve. And if they don’t really care, why call it “care” then? Why not call it cost-efficient and trouble-free bulk management of the elderly, for this is what it really is?”

This therefore brings us back to the real issues surrounding designing attractive homes, apartment and living spaces for an aging society. The traditional models for seniors hold little or no appeal to the baby boomers. As the sociologist Richard Sennett said in an interview with *Süddeutsche Magazine* about new forms of communal living, “For older people, communal living could represent a great achievement. There is an extensively discussed experiment where old people live together with students. I am interested in these types of communal living facilities because I am old myself. I do not wish to spend 15 years in an old folks’ home. I would like to have young people around me, smoking and keeping me supplied with cigarettes and everything else not generally available in a normal old folks’ home.”

For many architects and designers the challenge lies in creating so-called assisted-living or universal design that does not look institutional or ugly. Not everything for older people that assists with movement and agility in the home has to look as if it has been made for a hospital or hospice. It needs to be for a generation of design-conscious people - free-agers whose taste and design demands

are still determined by their “youth”. This, remember is also the first rock and roll generation who grew up with Woodstock, the Rolling Stones, the first big ecology and anti-nuclear movement. Their ideals are thus tied to the aesthetics that we associate with this period - natural materials such as wood and experimentation with design. The new appreciation of handwork, the trend towards building with wood and CLT (see the *Material World* chapter) is a testament to their taste and a hint of the potential for the future.

Joseph Coughlin, founder and director of MIT’s AgeLAB, points out, the vast majority of baby boomers want to age in place - they want homes for a lifetime not just a lifestyle. They should optimise not just physical but emotional well being and be profoundly flexible. Furthermore, according to Coughlin, the house of the future should be looked at “not just as an elegant structure in which to live well but also as an elegant platform to provide the services of the future... the design of those homes must remain profoundly adaptable to facilitate the service and home-care providers who will be coming in. Your house has to be designed for a modular, open experience that allows for a change of technology every five years and a change in your well-being even sooner.”

When the Who sang “I hope I die before I get old” in their song *My Generation* back in 1965, it was unlikely they thought that the lead singer Roger Daltrey would still be singing it today at the age of 72. The fact that he is, is testament to the vitality of that generation, and their need and determination to stay young at heart forever.

## Womanomics and gender shift

Gender equality is more than a goal in itself. It is a precondition for meeting the challenge of reducing poverty, promoting sustainable development and building good governance. **Kofi Annan**

Men, don’t panic yet, gender shift is nowadays not only about women earning more and being on average better educated



Photo: © PAUL ÖTT PHOTOGRAPHIERT

than men. It is also about women having more say and influence on how we will live in the future - both as employees in one of the many branches of the building industry and as end consumers (those home makers/owners who make the main financial decisions).

Clearly someone also got the message at toymakers Mattel. In 2011 they proudly launched the new Architect Barbie - their modern addition to their "Barbie I can Be" series. She wears trendy black-rimmed glasses, a dress with a skyline print, and carries a pink blueprint file. And she naturally has the legendary Barbie figure. So, are female architects (with a perfect figure) the future? Currently only around 20% of worldwide registered architects are women, though it is said that in the first year of architectural studies 50% of students are female, and that the high dropout rate is due to the working hours. However, you would have gained a different impression if you had visited to the annual meeting of women in the timber construction industry in Meran (South Tyrol). Here it was noticeable that, of the 150 or so female delegates, a few men who were

in attendance were busily employed outside the main conference room looking after the babies and children of the participants. Also surprising to some (men) is the fact that this conference, which is exclusively for women in the industry, has been going successfully for 13 years.

If women are the ones earning equal wages, they will also be the ones who are increasingly determining who builds or decorates the home - and how. Just as women are nowadays considered the key decision makers in the traditionally male-dominated field of car buying, we also know that they have more control over the household budget and spending than men (or than men like to think). The implications for marketing in the building and housing industry - in terms of the whole range from architectural materials, to design and furnishings - are as yet underestimated and ripe for a rethink. This potential becomes clear if you consider one of the big debates at the moment in the USA - one which is also heading here to Europe. It centres on the needs and demands of a rising and powerful demographic of young single women. The

The Peter Rosegger care home by Dietger Wissounig Architekten (interview on p. 63) is a passive house constructed of CLT.

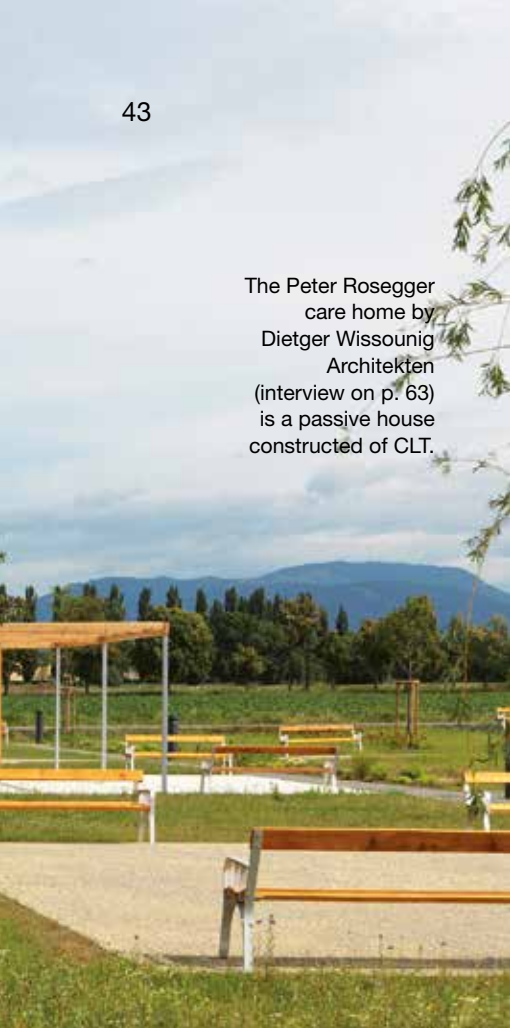

key demographic is that single adult women now outnumber married adult women in America. Overall, 53% of adult American women are now single.

So what do they want? Is it sex, career, power, clothes, money, friendship, husbands, children – perhaps all or even maybe none of the above? According to Rebecca Traister, author of *All the Single Ladies: Unmarried Women and the Rise of an Independent Nation* – what they really want is the freedom to shape their lives in ways they, society, and men, are only beginning to understand. New York author Rebecca Traister believes single women are a revolutionary force challenging social definitions, getting married later in life, or not at all, and changing “everything about the way the nation works” from politics, to work and housing. As she points out, singlehood is no longer as restrictive for women, “Independent women living outside marriage threaten all kinds of things about the way power is supposed to work.” Author of *Spinster* Kate Bolick says it’s not economic conditions that have changed but the numbers entering womanhood and setting forth. “The fact that women

are coming of age with a rich conversation on this topic is exciting. It bodes well for individuals and society as a whole.” She adds: “Marriage is not going away. It’s just that people are staying single longer. In a world where everything is permissive, it puts the onus on women to figure out what they want. But we know marriage is not the right option for a lot of people.” Just think of *Sex and the City*, which diverted feminist dialogue toward freedom through fashion and mate selection. When the series started 18 years ago it brought radical new visions of the lifestyle and interior style of single women, not least how they like to live – and not just in terms of building sexy shoe storage cupboards. Their potential and purchasing power in the housing market is all the more apparent if you consider a survey that showed single women bought 24% of the homes sold in the USA during 2008 and single men only 9%.

## Generation Y : millennials on the march



I don't want to be a part of the demographics. I want to be an individual.

John Carpenter, Film Director

Another key demographic group that is facing unique challenges of how to live are the millennials. This is a generation of young adults facing a combination of debt, joblessness, globalisation, and rising house prices. A recent investigation by the UK-based Guardian Newspaper showed how the falling incomes and prospects of millions of young people across the developed world is resulting in unprecedented inequality between generations.

The Guardian investigation into the prospects of this so-called Generation Y (or Generation “Why” as is often joked), born between 1980 and the mid-90s, has found they are increasingly missing out on the wealth generated in western societies. The newspaper discovered that in seven major economies in North America and Europe, the growth in income of the average young couple and families in their 20s has lagged dramatically behind national averages over the past 30 years. It calculated

that thirty years ago young adults used to earn more than national averages, whereas today in many countries their earnings have slumped to as much as 20% below their average compatriot. The free-agers have by comparison seen their income soar. It is said to be the first time in industrialised history (except for periods of war or natural disaster), that the incomes of young adults have fallen so far when compared with the rest of society. In summing up the study found that:

- Prosperity has plummeted for young adults in the rich world.
- In the US, under-30s are now poorer than retired people.
- In the UK, pensioner disposable income has grown three times as fast as the income of young people.
- Millennials have suffered real terms losses in wages in the US, Italy, France, Spain, Germany and Canada and in some countries this was underway even before the 2008 financial crisis.

So what are the implications for how and where we will live. Angel Gurría, Secretary-General of the the Organisation for Economic Cooperation and Development (OECD) says that the situation is tough for young people, “They were hit hard by the Great Recession, and their labour market situation has improved only little since. Reduced income means that independent living and getting onto the the property ladder will be slower and harder.” The trend towards innovative co-housing schemes, shared and smaller living spaces, and cheaper building solutions are just part of the solution. As one interviewee, Fiona Pattison, a 30-year-old accounts director pointed out, “My lifestyle has remained exactly the same [for six years]”. Pattison, works at a fundraising agency, and despite pay rises and promotions her lifestyle hadn’t changed in six years. “Everything I’ve made in terms of a pay rise has gone into living and saving,” she says, “My lifestyle has remained exactly the same. Any dent in employment or income would mean I’d have to go back to sharing again.” Similarly, Londoner Tanaka Mhishi, who works in a bookshop, says, “I definitely think in a lot of ways my parents’ generation

The Tietgen Residence Hall in Copenhagen (Lundgaard & Tranberg Arkitekter) has 30 accommodation units for communal living each with 12 single rooms sharing a common area, kitchen and terrace.



was luckier. They had a lot more freedom to do things younger: they were able to go straight from university and move to London and afford their own flat.”

This is the generation that was described by the New Yorker as “the most indulged young people in the history of the world”, but the new evidence would have it otherwise. Across Europe, the big issue centres around the lack of jobs and, as a consequence, the numbers of thirtysomethings still living with their parents (particularly high in countries such as Italy and Spain). This not only has implications for birth rates, but also for family formation in places where the demographics are already skewed towards elderly people. As Professor Diane Coyle, an economist and former UK Treasury adviser, points out, “We’ve never had, since the dawn of capitalism really, this situation of a population that is ageing so much and in some countries also shrinking, and we just don’t know whether we can continue growing the economy in the same way we once have.”



For singles the options are even more limited. The Guardian also reveals that singletons aged 25 to 29 in eight rich countries – the US, UK, Australia, Canada, Spain, Italy, France and Germany – have become poorer over the last 20 years compared with the average population, and many unattached young adults cannot afford to live alone. Coupled with an increase in the age of first marriage, more people were likely to live alone longer. Eric Klinenberg, author of "Going Solo: The Extraordinary Rise and Surprising Appeal of Living Alone" says "They're single, they're focusing on careers, and they are building an alternative support network of friends rather than having children, as their parents or grandparents did at that age."

Ashley Ball, 29, a legal secretary who lives in Portland, Oregon, also has had to face the fact that "I loved living alone in my own apartment, but my wallet didn't." She expected to be able to live the lifestyle she saw her parents living when she was growing up. "I found myself wanting two mutually exclusive things: great quality of life and financial comfort." Having lived for a while in shared accommodation she is now forsaking consumption to live independently. "I no longer indulge in fast fashion, I sold my car, I don't drink any more, I cook at home more than ever. I use the library instead of buying books. Some of these changes were hard. But the upside is, I can afford my own apartment again."

Apartment blocks, perhaps like The Rob Clark or The Marina Oakwood complex – just two of a series of singles-orientated apartment complexes in Los Angeles that offer small living units but extra amenities such as a billiard room, hot tubs, yoga classes, a screening room and free WiFi in public spaces. Most of the apartments have very small kitchens but large bathrooms – including, bizarrely, double sinks. As one resident of a particular single apartment block revealed, "I'm not supposed to have someone living with me but I should definitely show off the sinks (to my one-night stand) in the morning".

# Conclusion

**When we speak of demography, we should not forget that it concerns not only data but people, their longings and wishes, their lives and objectives. Individual stories do not describe exceptions, but the expectations of many generations.**

**Living relates increasingly more to the wider environment, the living space for all, and much less to "our own four walls". These changed, differentiated lifestyles therefore demand other strategies, flexible concepts and new technologies. Whether for new-build projects or the modernisation of existing buildings, we must take into account the requirements of new, diverse ways of living.**

**Ageless and universal design concepts ensure that residential buildings are designed to allow flexible, easy and intuitive use with a high tolerance for error – for all age groups. The principle of "co-housing", allowing for many different styles of community living, is another answer to the question, "How will we live in the future?"**

**All styles of living share the increasing need for a feeling of well-being in an ecological building – offering comfort, aesthetics and sustainability.**

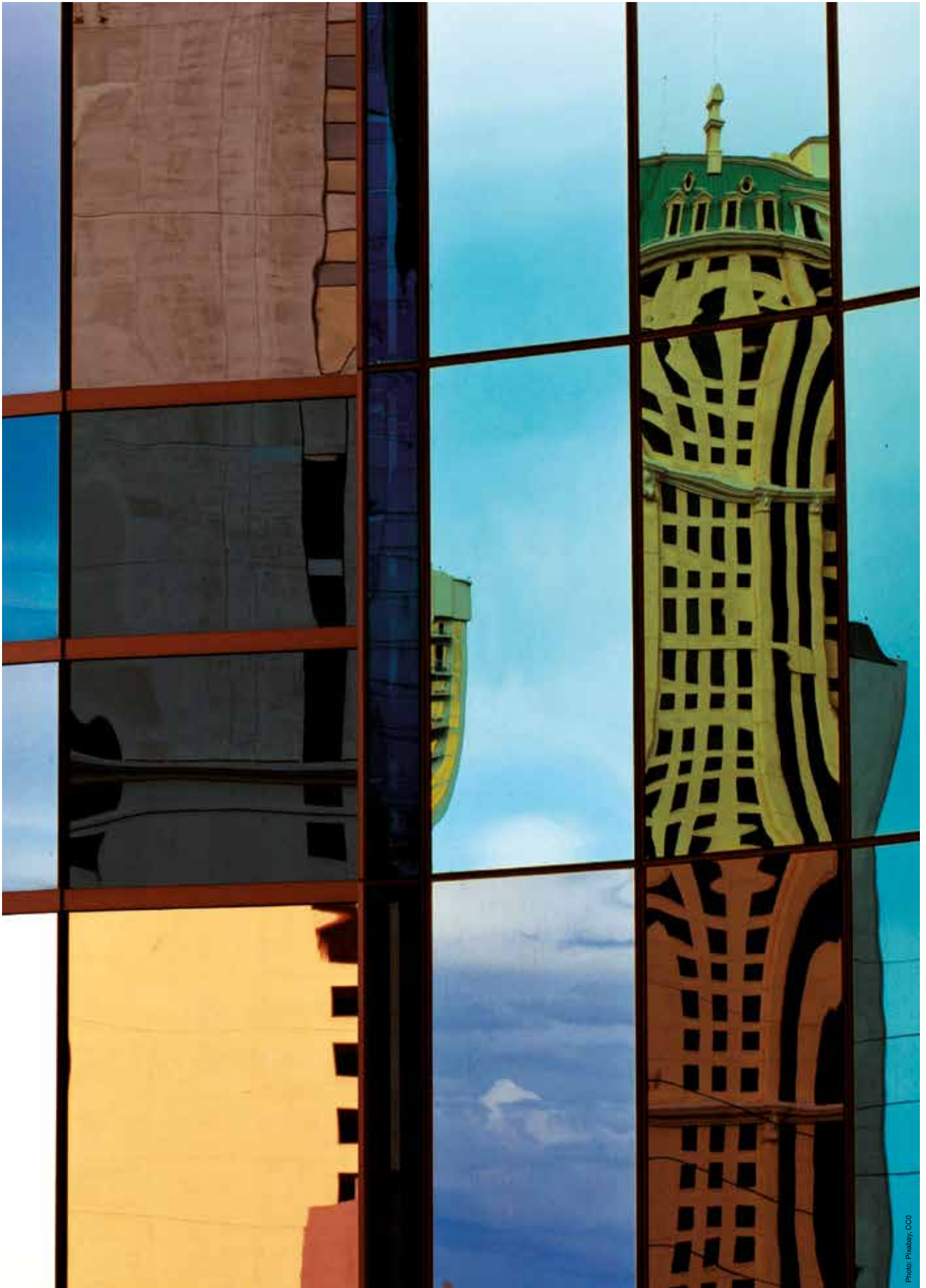

# How will we live in the Future?

Living cities, affordable homes, manageable and smart infrastructure in the context of diverse and flexible transport options (mixed ability) – the Urbanisation megatrend is a huge driver of new concepts designed to improve the quality of life in cities. Wood as a construction material opens up new possibilities – and will be requested much more by the customers of the future.

## Urban nomads, modular building and Slow Architecture

Increasing numbers of people will live in cities. A society of urban nomads has developed. There is a continuous flow of people. Consequently, there is a need for living concepts and furniture that can be adapted to suit this change. **Michael Michalsky, Designer**

Demographic change, complex relationship patterns, increasingly frequent change of jobs, of partners and therefore places of residence impose new demands on housing. At the same time, more people are looking to public areas to expand their living environment and seek more contact with the community, despite the increasing need for individuality and conscious striving for self-realisation. This gives rise to decentralised living cultures that build on a stronger sense of community. People do not necessarily have to own everything – service providers and collaborative arrangements can be the basis of flexible housing. A new form of

housing that precisely matches this lifestyle comes into play here: micro-houses (see below). Houses on wheels, on water (floating home), usually fully fitted-out with sleeping area, kitchenette, bathroom, living room and terrace. Micro-living further reflects the society of urban nomads and is also an expression of the "Collaborative Living" trend.



Photo: Wiki Commons, Guillaume Duthil, CC BY-SA

The target group varies and is interdependent upon the wide price range within which a micro-house can be built – namely between

EUR 15,000 and EUR 350,000. Whether as student accommodation, weekend home or business space – tiny houses are enjoying increased popularity.

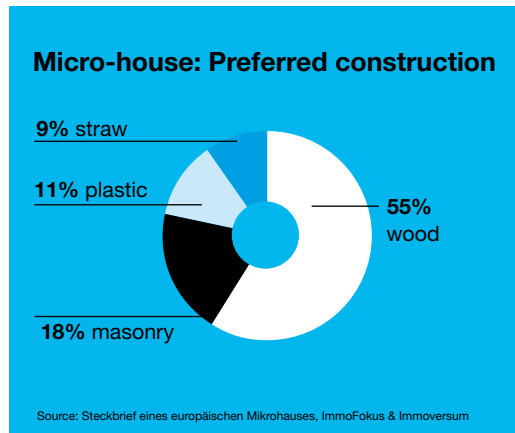

## Modular building with wood

Diverse lifestyles need a good mix. This is an elementary part of an open society – exclusion and ghetto building are the exact opposite. This is an urgent concern that requires rapid and resilient solutions because of the influx of refugees. Germany had over a million migrants in 2015, 442,000 of them have sought asylum. In the same year, Switzerland had 39,500 asylum applicants, in Austria the figure was 90,000.

An interesting question was raised in the media in this context: how can architecture respond responsibly to this? The cry "We must build more" is too one-dimensional; it is much more a matter of us building differently. Wood as a material is particularly suitable because it is not only visually such a refreshing contrast to steel containers, for example, but also offers outstanding functionality.

The architect Simon Speigner describes the reason why he considers modular building in wood to be a sensible option, particularly with regard to the refugee problem. "What often happens is that accommodation for refugees and other people in urgent need is substandard: it is just 'thrown up' and 'corners are cut'. Somewhere down the line, however, the refugees leave or are granted

asylum, which is why the accommodation should be built to a much higher standard in the first place. This would then allow it to be used for students or people who are not refugees. If, for example, I build refugee accommodation using modules and then this accommodation is no longer needed because all the residents have been granted permission to stay, I can, if I originally used smart modules, build a students' hall of residence out of them, or use the facility in any number of different ways." (See full interview on p. 66).

## Slow Architecture – the benefits of building "slowly"

The term Slow Architecture – like all other similar terms mentioned in this trend report – developed out of the slow food movement of the mid-1980s. The term refers to architecture that develops gradually and organically. Slow Architecture provides a counterpoint to buildings that are erected quickly and to designs for which no sustainable components were considered.

In addition to the use of natural materials such as wood or masonry, the basic idea of "generic architecture" also includes the integration of buildings into their own, individual surroundings. The architecture should ideally blend into the landscape, especially with the use of materials and architectural details typical of the region. The appeal of this approach is growing massively – particularly in societies where the vast majority of people live in cities and do not wish to dispense with the advantages of urban life. The extent of this yearning for the rural idyll and closeness to nature in combination with the modern zeitgeist is demonstrated in the uninterrupted success of magazines such as "Landlust".

Slow Architecture can also be taken literally, as quite deliberately "building slowly". One example of this is the monumental Sagrada Familia structure in Barcelona, which is yet to be finished. The foundation stone of this famous church designed by Antoni Gaudí was laid in 1882. Based on the current situation, completion is planned for 2026, which will be the centenary of



the famous Spanish architect's death. When questioned during his lifetime about the long construction time, Gaudí answered, "My client is not in a hurry." The complex structure still looks as if it is under construction and has become Barcelona's trademark.



## Slow Architecture and the power of globalisation

That people find increasing pleasure in the principle of Slow Architecture today, in these times of increasing complexity and the resulting questioning of the traditional economic model of industry, is no accident. As in many other industries, a change of values towards the rediscovery of quality and craftsmanship based on an increased awareness of our responsibilities can also be seen in architecture.

Although a key aspect of the Slow Architecture movement describes something that has always been self-evident in traditional craftsmanship – working with natural materials and traditional forms of building there will, in future, be much more at stake than (only) the building. The whole approach of Slow Architecture focuses on the following question: "Can Slow Architecture fashion a new relationship between city and landscape?" (Grohe 2014)

The difference to "earlier" is set out below – and on several levels. The ability to think

outside the box is no longer simply an option, it is a mandatory precondition for individual companies to remain in competition. The market has become global and the competition no longer comes only from the same country or region, but quite often from the other end of the world.

"Think global, act local" – the old motto of the environmental movement is also highly topical in global culture. What this guiding principle addresses is expressed socio-culturally by the term "glocalisation", in line with which society turns increasingly to the resources in its own regions, nearby areas and localities, but without losing touch with the rest of the world.

"Too great changes in only a few years have caused us to feel alienated. This is the topic of our times: people don't feel at home in the world they live in. In this, architecture plays a main part, because we live in houses, towns and landscapes," writes the author of the website **Slow-Architecture.com**. According to the architects, the reason is obvious: these massive social and economic changes have led to people becoming estranged in many ways from the world in which they live. Architecture has a crucial role to play to give them a home again in the future.

## Sensory branding: the identity of buildings, cities and regions

It is also important to appreciate the place where you live for what it is: a unique combination of nature, architecture and culture. Places influence individuals on three levels:

- **the location and its surroundings,**
- **the architecture,** which can showcase a place or destroy it,
- **the rituals** that are played out at a place.

Together, all three aspects of a place lead to or provide experiences. This underscores that in future everything relating to spatial planning and the architectural design of buildings will primarily revolve around issues



Thermal baths in Vals, Switzerland

Photo: Flickr, kres, CC BY-SA 3.0.

such as origin, authenticity, characteristics, diversity and, lastly, regionality. Slow Architecture successfully combines these very components. If they are combined with a globally networked view, the results are real, local and sensual experiential spaces. If the individuality of a region is conveyed through its buildings in a manner that engages the senses, then public awareness is as good as guaranteed. In marketing language, this focus is also described as the sensory branding of buildings, perhaps even cities or regions. Slow Architecture achieves this very successfully primarily through the use of natural and regional building materials.

## Materials of Slow Architecture

In addition to stone, two of the favourite building materials used in Slow Architecture are wood and loam.

→ **Stone:** One of the most famous examples of Slow Architecture is the thermal

baths in Vals, Switzerland, designed by architect Peter Zumthor, who is well known for his extraordinary buildings. He used gneiss from a nearby quarry for the Vals thermal baths and clad the existing hotel building with the same material, thus making reference to the quarry itself. The plain design fuses perfectly with the clear and cool aura of the 60,000 slabs of Vals stone, iridescent in all nuances of grey. Zumthor's thermal baths are right at the top of the visiting list of international architectural tourism and pays graceful homage to the archaic Vals valley in the Swiss canton of Graubünden.

[www.therme-vals.ch](http://www.therme-vals.ch)

→ **Loam:** An increasing number of architects and engineers see loam as a building material of the future, with many advantages over conventional alternatives. Most notably, loam creates a healthy climate by absorbing moisture in the air but then quickly giving it up again if the air becomes too dry. Loam stores heat, can be reused or disposed of without problem,



Photo: Wiki Commons, Tony Webster, CC BY-SA 4.0.

The Kapelle der Versöhnung (Chapel of Reconciliation) from a design by Berlin architects Peter Sassenroth and Rudolf Reitermann was built by Lehm Ton Erde Baukunst GmbH and is the first rammed loam building in Berlin.

absorbs pollutants without returning them to the air and the energy consumed during its preparation is unbelievably small. The ecological potential of loam as a building material is therefore enormous – because it is available in huge quantities in many locations. Moreover, the aesthetic appeal of unplastered rammed loam walls contributes significantly to the change of image.

→ Austrian architect Martin Rauch has researched and worked with rammed loam in many areas of construction for over 30 years. His immense store of experience makes him a renowned expert in building with this ancient and yet uncommon material. With his holistic approach to his work, which combines traditional craftsmanship, artistic design and the naturalness of the material with innovative technology and state-of-the-art design methods, Rauch has become one of the protagonists of Slow Architecture. His company seeks to develop effective construction methods and ways of living making optimum use of resources in

closed cycles based on the sustainability of loam construction, stepping away from ecologically inferior technologies and processes. “Loam, clay and earth are natural materials and are found in various proportions below the topsoil layer in all parts of the world,” writes Rauch on his website: “More than one third of the world's population live in houses that are completely or partially built out of loam. Up to 40 different techniques for building in loam are known to be in use. The techniques for building in loam are as different from one another as the local loam deposits themselves.”

**[www.lehmtonerde.at](http://www.lehmtonerde.at)**

→ **Wood:** Timber buildings have a particular association with nature. This fact is as simple as it is true. Huts and houses in rural regions immediately come to mind, but this is only part of the actual reality. City chic and wood will no longer be seen as contradictory in the future. This is despite the fact that urban life has always been equated with tightly packed collections of

## Sustainable buildings for cities that are fit for the future

Number of buildings and year with DGNB certificate for sustainable construction

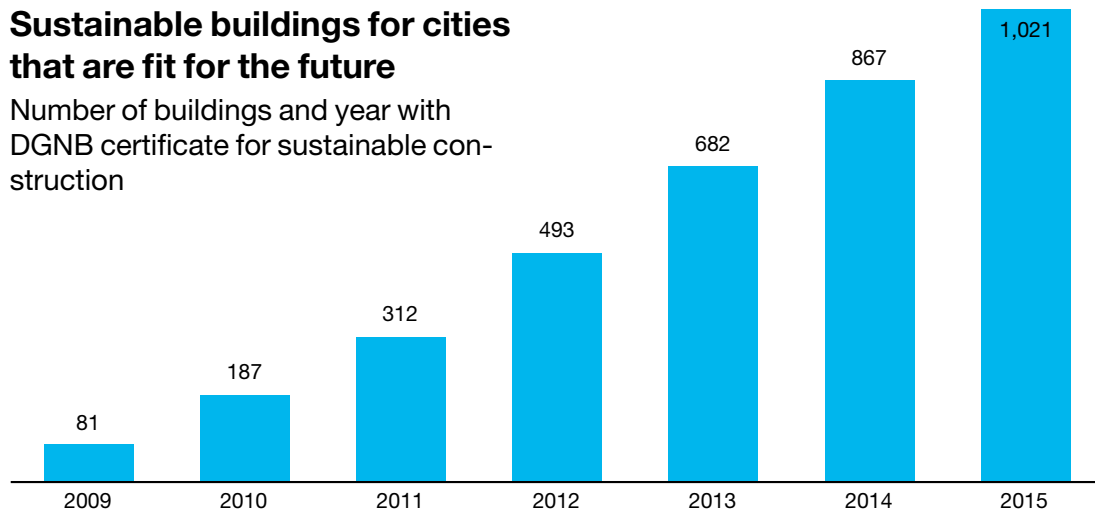

Source: DGNB

Date: September 2015

skyscrapers, street canyons between high-rises, convoys of cars standing in congested roads and the dominant materials of concrete, steel, glass and aluminium. The city of cities, New York City, provides the classic example. But all that is changing. An alternative to this image is on the rise principally in Europe, with a new quality-of-life, a vibrant mixture of tradition and innovation and the blurring of the erstwhile boundary between grey city and green countryside. The innovative use of wood as a building material has a crucial role to play here.

## Wood revolutionises building in the urban context

Wood as a building material is being (re-) discovered for a multitude of major projects, including those covered in this report. The models of the future are based on large centres of population with up to 24-storey towers with wood as the main construction material. These plans place conscious reliance on the positive properties of wood: it is lighter, is a better thermal insulator and is absolutely competitive with other materials. Modern timber architecture represents a new style of housing which is celebrated with demonstrable closeness to nature in our major cities. The renewable raw material will be used in future for creating urban landmark projects.

→ **Towers in timber:** Hubert Rhomberg, Head of Austria's Rhomberg Group, whose member company Cree designed the LifeCycle Tower, has this to say about the latest developments in his book, "Bauen 4.0 – Vom Ego- zum Lego-Prinzip" (Building 4.0 – From Ego- to Lego-principle): "Wood is on the way back as a construction material in the city." His innovative construction projects clearly demonstrate that timber buildings and towers do not have to be mutually exclusive. At the same time, this modular, industrially manufactured composite timber method of building makes it clear that this form of Slow Architecture is not in the literal sense about building slowly but, on the contrary, seeks to erect buildings quickly, cost effectively and above all in a resource-conserving manner. "Slow" in this context does not refer to low speed, but to achieving a higher social, ecological and efficient quality of buildings.

As paradoxical as it sounds, Slow Architecture like this can lead to a pioneering age of new, quick, systematic building which Rhomberg has in his sights; an age in which vertical hierarchies give way to flatter structures of cooperation, and collective intelligence takes decisions. "This has the potential to lead the building industry out of its crisis and into a new phase of growth," asserts the construction visionary.

[www.creebyrhomberg.com](http://www.creebyrhomberg.com)

## Sensitive architecture and empathetic building

Slow Architecture is an international phenomenon and its many guises include a new form of building which acts on a number of levels – real, emotional and moral. In Canada, for example, Slow Home Studios understands its work to be a critical answer to the unsatisfactory solutions offered by the mass-produced housing industry. “Our mission is to advocate for a more thoughtful approach to residential design that improves the quality of our daily lives and reduces our impact on the environment,” say the architects, describing their belief in and willing adoption of forward-looking building concepts ([www.slowhomestudio.com](http://www.slowhomestudio.com), Brown/North 2011).

Their objective: to build alternatives to the “fast homes” that they liken to fast food: a standardised, mass-produced commodity that at best excites short-term attention and arouses superficial desires. And finally they create nothing more than the illusion that they were made for people to live in. By ignoring the elementary rules of good design, “fast architecture” creates homes in which people can live only with difficulty and that have negative effects on the environment.

## Cooperative structures and collective intelligence

Collaborative principles are increasingly coming into play on building projects. Participative architecture is a logical continuation of the growing desire of people for coordinated self-organisation and the Slow Architecture approach. Participative building – or social architecture – functions in accordance with the credo: buildings are accepted and used ideally only if all stakeholders have been involved from the very beginning in the building process. At its heart – as with every participative process – is communication. Communication between planners and designers, clients and users, of course, but also between the local authority and the community.

# Conclusion

Those who build socially and ecologically must not overlook the joy of living, comfort and aesthetics, emphasises Danish architect Bjarke Ingels when describing himself and his work as “hedonistically sustainable”.

This concisely summarises what is special about the Slow Architecture trend. An “as well as” approach is becoming increasingly relevant and is leaving the familiar “either or” well behind. This form of architecture will in future continue to improve its position over the quick and “short-sighted” form of building and will become increasingly taken for granted. Thus new buildings and, over the long term, even whole city districts will be created that are not only economically efficient but also have special cultural and historic characteristics, and will, above all, function in a socially sustainable way. The ultimate effect on localities and regions will be that they gain their own individual charisma.



Photo: Flickr, Kevin Keaja, CC BY 2.0

# Wevolution – New Forms of Society and Cooperation

From I to we, from rivalry to rapport: any company wishing to survive on the market in times of globalisation should step away from the old idea of competition. This is no easy undertaking when it comes to the future agenda because more cooperation and collaboration with customers, suppliers, partners, and even competitors, will mean that we also need to become culturally aware.

It calls for nothing less than a paradigm shift. New forms of working together across borders demand a new level of openness and transparency. Yesterday's firmly defined boundaries and responsibilities will become permeable, after which will follow the first "fluid" organisations. Simply wishing for more "we" will not be enough: the conditions for cooperation must be carefully created and developed. This is just as true in society as it is in the competitive commercial environment. Only then can capable wes – and, in the end, true innovations – arise.

## From I to we in global culture

The rapidly increasing number of single-person households has long been seen as the indicator of an individualistic and egocentric society. The proportion of single households in Germany and Austria was

37% in 2014. In Switzerland this figure was 35% in 2013. However, the fear of cities becoming lonely places is exaggerated, because statistics do not take into account flexible lifestyles in society – single, mingle (singles in non-committed relationships), patchwork, living-apart-together relationships etc. Not everyone who lives alone is lonely. The pessimistic picture of egocentric and anonymous city dwellers is increasingly replaced by the image of a socially engaged urban population whose members are actively involved in their community. Social networks are the vehicle for initiating not-for-profit projects at which strangers meet and provide unremunerated services to the community. Public open ground may be cultivated as part of **urban gardening** initiatives, while **repair cafés** offer people the know-how to mend defective objects.



In Fablab Magdeburg



WikiHouse: a house built without any previous knowledge

The new urban we-feeling in connection with the refugees in Europe made a deep impression in 2015: new forms of organisation sprang up out of nothing, providing solid support to or even replacing public bodies or established NGOs. Initiatives such as the “Kleiderkammer” (“clothing store”) in the Hamburg exhibition halls, where volunteers sort clothes donated by Hamburg’s citizens and intended for refugees, are formed out of Facebook groups and organise their logistics, direct their donors and provide information about the areas of most need through websites. Helpers turned into organisers who, as a result of the population’s huge willingness to help, soon had to start distributing clothes according to actual requirements and to only accept donations that were acutely needed. Clever and professional logistics were the result.

Vienna's main railway station provided the focus for the “Train of Hope”, which sought to supply the refugees stranded there with food & drink, clothes, hygiene products and medicaments. What was first an unorganised social media event rapidly developed an organisational structure that was fully

independent of public bodies and initiated, organised and controlled the logistics for the collection and distribution of the donated items. The Connectivity and Urbanisation megatrends combined in these initiatives to create a functioning system.

→ The digital world reacts to this development with a multiplicity of new apps and platforms: **TaskRabbit** is a mobile online marketplace in which users can offer small jobs and tasks to people in their neighbourhood. Simply state the task you would like done, then the price. Once completed, just pay online. Community members can offer their services as taskers. Leah Busque set up the portal when she found she often lacked the time to buy dog food. The principle behind TaskRabbit is based on the traditional practice of helping your neighbour – except that it is mobile and online. Membership is subject to a criminal record check showing no previous convictions.

→ The **WikiHouse** grew out of the do-it-yourself principle and the idea of open innovation, i.e. the democratic and transparent access to specific processes.





Can a house be any more difficult to build than putting together an IKEA BILLY bookcase? Of course not, as long as it is a WikiHouse. This architectural concept is open innovation in pure form: the construction plans for the WikiHouse can be downloaded free of charge from the website in the form of an "open community construction set". The design is so simple that anyone can erect the building without any previous knowledge. It is even possible to use the Google SketchUp 3D modelling software to customise the design. The first WikiHouse, which was made from locally produced plywood, was built for the Gwangju Design Biennial 2011 ([www.wikihouse.cc](http://www.wikihouse.cc); [sketchup.google.com](http://sketchup.google.com)).

## The network principle will impact the future

The Connectivity megatrend promotes the principle of networking. The networked society marks a fundamental change in the course of social evolution. If we dare to briefly look back on earlier social structures, the archaic tribal society was followed by the traditional stratified society, while the modern

structural form of functional differentiation into clearly defined subsystems such as commerce, politics, science, law and art dominated into the late 20th century. This era of separate functional systems will now be superseded by new era of complex networks. "The structure of the next society will not be based on functional differentiation, but on networks," writes sociologist and systems researcher Dirk Baecker. This network society will generate a new model that "is as different from modern society as electricity is from mechanics".

” Co-working, co-living, co-gardening – new forms of social reciprocity, in which yesterday's I is being augmented by tomorrow's WE, are emerging everywhere in major cities. **Matthias Horx**

---

The possibilities offered by media and other forms of communication in digital networks today ensure – and will do so to a growing extent in the future – that systemic barriers will become more porous, and functional

attribution much more multilayered. This change in direction towards connectivity will lead to a huge increase in complexity. An abundance of new connective opportunities will open up at the new interfaces of formerly separate areas: for hybrid organisational forms and interdisciplinary alliances, for fulfilling objectives and needs in cooperation with others, for new types of communication systems – all operating in the "as well as" mode: individually as well as collaboratively, economically as well as ecologically, analogue as well as digital.

What does this mean for the timber construction industry? The same as it does for all other industries: the principle of networking is the order of the future. Without cooperation, without at least temporary, ad hoc relationships with partners, which make each partner's offers even more interesting, a company would be robbing its future-self of a crucial element: stability through flexibility. Moreover, good networking is always a catalyst for visibility and reach. The following questions need to be considered: What types of cooperation make sense for my company? What image would I like to communicate to whom? In what region should I be based and what should happen there?

### **Digital networking also leads to analogue networking: companies share and cooperate**

The currency of a future in which the world can be accessed as comprehensively and quickly as never before through the Internet, in which it is possible to communicate or do business with people who may live not in another city, but on another continent is simply trust. Nothing is more important and, at first glance, more difficult to communicate as trust when there is an abundance of choice. In times when we do not meet our business partners or potential customers face-to-face or know of them from a neighbouring town or city, nothing can mould our social relationships of the future any more effectively than trust.

In global culture, however, trust is established through earlier structures. It is no longer necessary to have known people for years in order to trust them. People whom you have never seen before, but who are part of the same "community" are credited with trust. This leads to "digital natives", young people who have grown up with the Internet, climbing into cars for a shared journey with complete strangers (**mitfahrgelegenheit.de**), travelling with a specific driver arranged by mobile phone instead of just hailing any available taxi (**uber.com**), letting others use their homes (**www.airbnb.com**) or spending the night on someone else's sofa (**couchsurfing.org**). Control is minimal and is achieved simply using the feedback functions in the online community in line with the converse of Lenin's quote, "control is good but trust is better".

Even successful companies do not operate in these structures as isolated organisations, but more as part of the networked "we-economy", which blurs the boundaries between different branches of industry. Companies will have to acquire new skills and expand their definition of success.

Working in networks cooperatively like this should, in an ideal situation, extend the competences of everyone involved. B2B-focused producers bring their manufacturing expertise honed for long-term performance and excellent operational reliability to the table, while B2C players know and are able to react quickly to the rapidly fluctuating preferences of the customer. The role of the gearbox, synchronising different speeds and integrating the various interests, can be played by bodies with knowledge of the regional economy to provide a platform for networking (B2B but also B2C). It is therefore all the more important for people to think beyond their own company boundaries and not to consider wealth-creation processes as a series of separate sections, but to take the logical step from I to we, from their own organisational unit to the collective. Naturally, this would also shift power and destroy structures and hierarchies – which should not cause companies to be anxious but rather encourage them to adopt innovative business models.

# Conclusion

In an economy that profits from having the least possible obstructions to the flow of information, company managers can no longer be allowed to think in terms of linear sequences in which one player's contribution to a project leads naturally onto the next, but should refocus their thoughts on interwoven networks.

Management's role tomorrow will not be limited to devising strategies in terms of the individual performance of one company, but to directing the drive to innovate and monetising the services of a cross-company network. Furthermore, the joint development of visions will be equally important as their cooperative implementation in the final products they bring to fruition together.

The first step in all this could be to take a differentiated view of the issue and be prepared to be inspired, disturbed or enlightened by different expert opinions.



---

Hybrid organisations can operate in the “as well as” mode: individually as much as collaboratively, while acting economically and ecologically.



In the we-economy, the boundaries between different branches of industry become blurred.



Innovations happen not through the efforts of individual players but in networks spanning all the industries involved.

# The Voices of Industry

Timber construction and the use of cross laminated timber constitute a diverse topic with a bright future. It was therefore necessary to provide a wide range of insights from a variety of perspectives for this trend study. To do justice to this expectation, several people were asked to contribute their thoughts: **Gernot Weiß**, CLT sales manager at Stora Enso, provided valuable insider information and sources; **Georg Guntschnig** acted as the contact person for the Zukunftsinstitut and added his knowledge about the innovative possibilities of CLT to the study (see page 78). The Zukunftsinstitut itself cast light on the subject following extensive research on both the quantitative as well as the qualitative sides through five expert interviews and a survey of architects, clients and structural engineers (see page 104).



## **Prof. Alexander Petutschnigg**

Prof. Alexander Petutschnigg has taught at the Kuchl Campus of the Salzburg University of Applied Sciences since 2001. He is Director of Studies for the Forest Products Technology & Timber Construction programs and departmental head of the Natural Sciences & Ecology and Economics & Projects programs.

The author of numerous scientific publications received the Christian Doppler Prize in the “Engineering sciences including environmental science” category in 2005.

The focus of Professor Petutschnigg’s research lies in the development of new products and processes involving biogenic raw materials, from the building industry to the furniture and wood products industries, and in the technological and economic optimisation of processes and products.

**1. Professor Petutschnigg, wood is becoming increasingly popular in our society and therefore will feature more highly as an appropriate material for future buildings. How do you see the development of wood and, in particular, its use in the building industry?**

The demand for unprocessed, raw wood in the form of boards, posts, rafters and purlins will remain the same in terms of economic significance and therefore the growth of this type of use will stagnate. On the other hand, wood-based materials will experience an increase in demand. These materials can be used more simply and more flexibly in construction because they allow structural components to be made that are longer and wider in comparison with the dimensions of the tree. It is also possible to match the properties of these construction materials to more closely suit their intended function with respect to building physics and structural design, and to achieve homogenisation of these properties.

**2. What makes a timber structure special in your view?**

What sets timber construction apart is the possibility of prefabrication. Its scope covers everything from high-quality prefabricated components right up to finished building systems with integrated functional and technical building services equipment. This makes timber construction rather special. There are also the material's ecological properties, which are particularly supportive of sustainability.

**3. How would you assess the cooperation between science and industry, with particular regard to ensuring the future viability of timber construction?**

What's happening at the moment is that new timber construction materials are being approved for use in building. This is based on the inclusion of these materials in the standards. What would be necessary for the future and for the future development of timber construction is, for example, for

science and industry to work together on the integration of technical building services equipment into timber construction products. It is not only the material that is important here. The customer would like a building, or perhaps functional solutions such as walls, in which electricity, water or other connections to services can be placed in predefined positions. The timber construction industry has to think about what these solutions would entail. It is not only a matter of creating a wall element out of wood and complying with the requirements of structural design and building physics, there are also building technical services questions to be answered. These often relate to the outside of the building, such as how photovoltaics could be integrated or how provisions could be made for the needs of electric vehicles. In the interior of buildings, there are questions of aesthetics, usage questions concerning water and power, as well as furnishings to be considered. Such issues need to be considered by both sides, by science and industry, in order to make the most of their potential in the future.

**4. What changes have been most significant for you in the construction industry over recent years?**

For me, two points are significant and they have been very well documented. The first trend is that, in addition to traditional new buildings, the refurbishment of existing buildings and achieving greater density of development are gaining in importance. The second trend concerns better planning and the reduction of building costs through improved design. Fewer decisions will be taken on site, with the result that individual stages of production can take place earlier in the life of the project and the processes on site can be designed to involve less work. These trends represent general developments and have provided opportunities for timber construction, which the industry has exploited. I see timber construction as part of a very positive development and in order to play its full part, the timber construction industry must itself evolve.

” Clients should start to see their buildings as things that will not be there forever – and timber has a great advantage in the demolition phase

**5. What areas will provide the greatest challenges to the construction industry in future and what role can a material such as CLT play?**

I believe we are not yet using cross laminated timber in a sufficiently smart way. It works well as a material, but it still needs to be further developed in order to fulfil other functions in addition to providing strength and the enclosing room surfaces. Further developments need to take place, perhaps not in terms of the material itself, but in relation to the components. The way it is combined with many other building materials – for example, wood combined with concrete, metal or fibres – has scope for improvement. One challenge for the timber construction industry is the question of how we should handle such mixtures of materials and highlight their benefits for the demolition phase. Wood has a great advantage here, and one which is currently not sufficiently exploited. It could be argued that this advantage is not yet considered seriously enough by the end customer. In my opinion, if end customers were confronted with the facts, they would completely rethink their role in a throwaway society. Customers could then begin to see their buildings as something that would not be there forever. Demolition offers a potential that can be realised very effectively with high-quality timber construction design.

**6. What do you believe will change most drastically in your industry in the future? (New forms of cooperation between industries?)**

I believe that the construction industry, in a similar way to that experienced in other related branches of production, will become increasingly dominated by the provision of services. Services are contributing more and more to the total output of industry. What will become important in future will no longer be only the traditional building process as it was defined in the past, but the interface with the user or customer, including the whole subject of maintenance and the provision of advice and assistance. This will also offer some major financial opportunities. Other industries are already familiar with hybrid products. However, it's no longer just the product, but also the services associated with the product that will play a significant role.

**7. The future does not happen all by itself – we help to form it in the present. What must happen now so that we do not fall behind in a globalised future?**

The construction process is associated with very large volumes and huge movements of bulky materials. It is important for regional providers to position themselves in the market and make the most of their core strengths and their potential for success. Only in this way will they be able to survive global competition. Local actors have the big advantage that these large volumes do not need to be moved over quite such long distances, their logistics are flexible enough to be optimised and their employees with the necessary knowledge are already on the spot.

**8. Would you like to add anything? Have we covered everything adequately?**

I would like to raise the question of the increasing technical nature of components and buildings. The proportion of turnover contributed by services is continuously increasing and this potential should be fully exploited and extended. It is important, however, that buildings remain viable for the users for longer, with the result that "low-tech" solutions are often the better option in the medium to long term. Research must therefore take place, not only in the attention-grabbing high-tech area, but also in the development of alternatives for reducing complexity for clients, contractors and users.



Photo: Dietger Wissounig Architekten zt gmbh

### **Dietger Wissounig, Architect**

Dietger Wissounig studied architecture at Graz University of Technology (TU Graz) after graduating in structural engineering from technical college. After a final-year thesis on a project in the Klang Valley in Malaysia, he founded his own practice “Dietger Wissounig Architekten zt gmbh” in Graz. For several years, he was a visiting lecturer at TU Graz and a member of the architectural advisory board of the Südsteirisches Weinland and Wels nature park.

Dietger Wissounig Architekten has been responsible for some outstanding and award-winning buildings which were designed for sustainability and to be erected very quickly: the Peter Rosegger care home is a prefabricated timber structure designed to meet passive house standards and built in cross laminated timber.

”

Today, wood is seen as an expression of a contemporary attitude to life.

### **1. Wood is becoming increasingly popular in our society and therefore will feature increasingly highly as an appropriate material for future buildings. How do you see the development of wood and, in particular, its use in the building industry?**

There is much to say in favour of wood. In addition to the obvious positives, such as sustainability and ecology, other aspects also favour wood, especially those relating to indoor climate and the proven occupant health benefits of the material in building construction. To this can be added psychological aspects, such as those that can occur through the use of Swiss pine. That wood is able to position itself to be an expression of a contemporary attitude to life today is thanks to the high architectural quality of timber buildings erected over recent years.

### **2. What areas will provide the greatest challenges to the construction industry in future and what role can a material such as CLT play?**

The advantages of cross laminated timber lie in the possibilities offered by prefabrication, reuse and recycling of the material. Equally positive are the use of modules, the shorter construction times, and the wider coverage by standards and codes of practice.

### **3. Do the existing construction standards and legislation governing timber construction require amendment in order to keep pace with changes within the construction industry, or are they simply obsolete?**

In general, construction standards and legislation are rather more centred on solid wall construction. In future, construction component testing should be further developed so that appropriate and suitable construction options are available for every situation. I believe, for example, in having a practical external wall design that can fulfil fire protection requirements such as REI 60 without having to use a de facto unprotectable gypsum fibreboard as the outer surface of a framed wall.



Photo: STUDIO/WG3

### **Christian Reschreiter, Architect**

Christian Reschreiter studied at the Graz University of Technology (TU Graz) after completing an apprenticeship in carpentry and attending a furniture design college. Working with Matthias Gumhalter during his time at TU Graz, the graduate architect developed the Hypercubus – a modular housing unit that can be cost-effectively manufactured and transported from one place to another. In the course of his studies, Christian Reschreiter and three colleagues also founded the group “WG3”, which still meets today. WG3 focuses on architecture and in particular on multifunctional furniture that can fulfil a wide range of purposes by simply arranging and connecting the elements together in various ways.

”

In terms of its accuracy, timber construction is simply much better than masonry or concrete.

### **1. Mr Reschreiter, the mindset in our society with respect to greater awareness of ecological and healthy materials is much more pronounced than ever before. How and in which form do you notice this in your daily business?**

We are building something in wood right now, and we have recently finished constructing a mobile hotel room with Bernd Troppmann, who works for Stora Enso. The degree of prefabrication and the ecological credentials of timber construction are seen as providing great advantages, particularly during manufacture. In our practice, we value this prefabrication and precision because, as carpenters, we have a practical background and found ourselves involved with wood again while studying architecture. We believe that the advantages of timber construction lie in this prefabrication and accuracy.

### **2. What makes a timber structure special in your view?**

In terms of its accuracy, timber construction is simply much better than, for example, masonry or concrete. Prefabrication is naturally an advantage because the work is sheltered from the weather and other environmental influences. I deliver my components to site and then all that needs to be done is to ensure they do not get wet or exposed to other effects of the environment. That's actually all there is to it.

In my opinion, wood is extremely advantageous on multistorey buildings, for example, during a refurbishment project. Its light weight and strength are perfect when converting the roof space. When it comes to speed, wood also wins, because timber construction does not require time to cure or dry out and can be used immediately. Wood is also highly beneficial to room climate.

One small disadvantage of timber construction relates to heating and noise, for which solutions have already been found and proven to be very effective. The design of top floors needs to be handled carefully from a building physics perspective.





### 3. How do you see the development of wood and, in particular, its use in the building industry?

The use of timber for constructing detached houses is still likely to increase further, even though it is already widely used in that sector. In my opinion, wood will make further inroads into housing construction, basically because a great many buildings are now being refurbished. Instead of being replaced by new builds, they may well have extra floors added. Private houses are being renovated, not least because the younger generation prefer to stay in their home areas and upgrade existing buildings. Wood can be used to good effect here, particularly in the upper storeys.

### 4. What areas will provide the greatest challenges to the construction industry in future and what role can a material such as CLT play?

The greatest challenge for us in our practice at the moment is the huge range of different products released onto the market by a large building industry. The building industry,

of course, plays an enormous part in the preparation of standards, because having the relevant statutory provisions and continually updated standards in place is so important. There is still much work to do on official standards and regulations. They will have to be made more practical and simpler, because the complexity of planning legislation has increased over the last five to ten years and has had an immense effect in raising building costs. Cross laminated timber is already being used successfully and has experienced an upward trend over recent years. It has been greatly improved, particularly in terms of structural engineering and building physics. There are, however, some regulatory requirements affecting CLT, for example the energy level and other highly complex considerations, and work is progressing on these in the background.

I am a fan of wood, otherwise I would never have become a carpenter. It is tremendously important for us as designers to find the right material for each project, therefore we consider almost any material fit for use, as long as it can be used correctly.

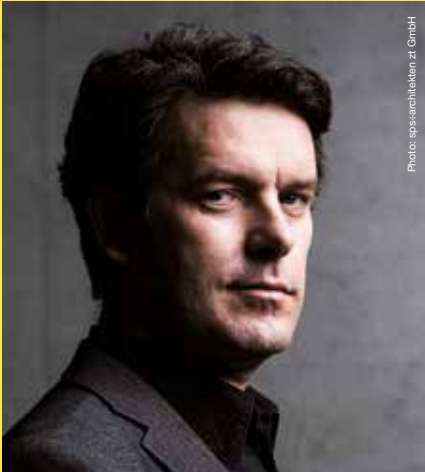

### **Simon Speigner, Architect**

Simon Speigner studied architecture at the Universities of Technology in Graz (TU Graz) and Vienna (TU Wien) and founded the sps-architekten zt gmbh architectural practice, which is currently based in the passive house building oh456 in Thalgau. He lectures at the technical university and the BAU-Akademie Lehrbauhof in Salzburg and is a member of the extended board of the platform for architectural policies and building culture.

The sps-architekten practice has received multiple awards for its timber buildings: two of its residential buildings in Salzburg were nominated for the Salzburg 2015 Holzbaupreis (timber construction award) and the Hallein retirement home project received a commendation.

### **1. Mr Speigner, you have already completed several temporary buildings and modular structures. What do you see as special about this type of building?**

Modular construction is special because it is mobile. At some point in the future, the modules can simply be picked up and moved to another place. I can erect them relatively quickly, use them several times and combine them in different ways.

The greatest advantage of modular construction is that the final structure is not permanently connected to the ground, therefore it can be taken somewhere else. This fact is not only an immense advantage in matters of construction law, but also if the land is subject to a loan for use agreement or precarium. The building owner does not necessarily have to own the ground because he can simply return it again later. In addition, I can resite the building many times because I can lift the whole thing up in modules.

Another advantage, when seen from the aspect of series production, is that modules can be prefabricated to unbelievable precision and most of the production is supervised in-house. For the site supervisory staff, this means fewer inspections and a better finished result. Production operatives are protected from the weather. Modular construction has some minor limitations, such as maximum weight or size limits for transport and the necessary preparatory work on site has to be completed in time.

### **2. Our lives are much more fragmented in today's society, we are generally more mobile and may move our base to different places. How important is or will temporary construction become?**

We have developed a concept in which a house may grow or shrink. When a couple want to move in together, she has one module, he has another. They decide to start a family and have a child. So they add a small module, possibly followed by a fourth or fifth, depending on how the family grows and their financial means. At some point, they decide to separate. The two go their separate ways and take their modules with them.

” Wood delivers better quality than conventional masonry construction and its reusability provides savings on the overall cost.

### **3. Do you think the rental prices of these types of dwellings are likely to change?**

It is difficult to say, land prices could always be cheaper. What I have certainly noticed with timber construction and what perhaps will have some effect on prices is that it delivers a better quality of product than conventional masonry or concrete construction. On top of this, timber construction should produce a saving on overall costs because of its reusability. Modules can be set up anywhere and later separated from the plot, resold or combined with other modules. The module can be simply reused, added to another module or dismantled into its individual boards, which could then be reused. If I then have no more need for the boards, I can shred or thermally recycle them, providing the appropriate adhesives were used.

When whole lifecycle costs are considered, timber construction represents the most cost-effective option.

### **4. Have temporary buildings a role to play in the present refugee problem?**

Yes, we have designed a project in solid wood construction for this purpose. This form of construction is perfect for the refugees because buildings can be erected quickly and, as explained above, they can be used to accommodate other people or for a different purpose. I can build something from the types of board available today that will be better than any kind of tent. The project was originally intended for emergency accommodation. What often happens is that accommodation for refugees and other people in urgent need is substandard, just “thrown up” and “corners cut”. Somewhere down the line, however, the refugees leave or are granted asylum, which is why the accommodation should be built to a much higher standard in the first place. This would then allow it to be used for students or people who are not refugees. If, for example, I build refugee accommodation using modules and then this accommodation is no longer needed because all the residents have been granted permission to stay, I can, if I originally used smart modules, build a students' hall of residence out of them, or use the facility in any number of different ways. The initial procurement costs may be more, but the building can be used for different purposes later, thus making the extrapolated cost lower. I would have to upgrade the substandard buildings, or expensively dispose of them. Modular construction can also be used for schools and classrooms by fitting together several open-sided modules.

Modular construction provides one option, but it is not the solution for all tasks because the demands of architecture can be many and varied.

### **5. Do cultural differences exist in the context of temporary buildings? In Japan, for example, buildings are designed for a much shorter life than in Austria, where buildings are expected to last for several decades.**

There are probably differences in requirements, with respect to temperature behaviour, size and construction

” We no longer have to think linearly in terms of columns, beams, struts etc. Now we can suddenly start thinking in terms of sheets and panels.



The Hallein retirement home by sps architekten was built using the timber cell construction method with a high degree of prefabrication.

requirements (earthquake resistance, fire protection, construction regulations etc.). Timber modules have the great advantage of being relatively light, which means I can place them on top of existing buildings. Flat-roofed buildings can thus be made much more interesting. I can, for example, build quite a few homes on top of commercial or industrial premises. In addition, I can design them to make use of the waste heat from supermarkets, which generate plenty of heat from their refrigeration equipment. This is an opportunity to use heat in a much smarter way than before.

#### 6. What makes a timber structure special in your view?

The atmosphere and comfort, because exterior shell of the building cannot radiate cold. Wood is a poor thermal conductor.

You can feel this in buildings when you walk from a solid-walled section into a timber section. Other aspects, such as sound and thermal storage also have roles to play. One disadvantage of timber construction relates to fire safety, which once was something to worry about. Since those times, designing to achieve fire safety has become completely standard practice. Wood is also a renewable raw material and naturally performs better in this respect than masonry, plastics or other artificial construction materials. Nowadays, a wide range of different wood-based materials is available, and wood can act as insulation as well as a loadbearing component.

#### 7. In your opinion, what role does cross laminated timber play in the construction industry and do you see its use changing in future?



CLT is an Austrian invention that has prompted a revolution in housing construction. We no longer have to think linearly in terms of columns, beams, struts etc. With timber construction, we can suddenly start thinking in terms of sheets and panels. From the structural analysis perspective, this represents a huge advantage and is an innovative feature.

The material was used only in Austria at first, but since then the market has broadened and now CLT is exported all around the world. When we use CLT in our buildings, it is remarkable how much interest they attract from abroad. I believe that there is a great future for these buildings and many more will be coming our way. When I was at university, it was only the beginning, today there is now much more potential.

## **8. What do you believe will change most drastically in your industry in the future?**

Lifecycle thinking is making its entrance. Today, we no longer speak purely about building costs, we are now speaking about lifecycle costs. The ecological approach, now widely accepted, plays a role in this and has handed wood as a material a great advantage. Satisfying the regulatory fire protection requirements for wood was an almost insoluble problem for a long time. This has become a non-issue again today and there are ways to get around it. Building ecology and lifecycle thinking are becoming increasingly important in our industry – which is grist to the mill for the renewable building material. This will gradually lead to a rethink within the construction material industry.



### **Günter Lagler, Architect**

Günter Lagler studied architecture at the Vienna University of Technology (TU Wien). Today, he is the co-founder of the Baukult architectural practice in Vienna, which works in the fields of refurbishment management and consultancy.

Baukult won the Lower Austria Timber Construction Prize 2012 for its “Knofeleben” project, which used local wood types appropriate to the site with a high degree of prefabrication and has achieved an excellent aesthetic result.

### **1. Mr Lagler, have you planned or completed construction projects in which wood was used as a loadbearing component?**

We did just that in a project for a mountain cabin. This ambitious project won the Norwegian Timber Construction Prize 2012.

### **2. What makes a timber structure special in your view?**

Prefabrication makes wood especially suitable for quick, dry construction. Prefabrication can be scheduled to help reduce completion times and minimise cost risks. Speed of construction is an important competitive factor, particularly on exposed sites and in densely built-up areas. Left exposed to view, the surface looks warm to touch and is more acceptable to building users.

### **3. How do you see the development of wood and, in particular, its use in the building industry?**

The use of wood is subject to the applicable construction regulations, which can frequently thwart our plans, depending on the specific federal state involved. Almost as relevant here are the higher production costs, which could be optimised in the future, depending on the degree of penetration in the industry. Compared with the car, another mass-produced article, where just-in-time, individually designed vehicle series can be manufactured cost effectively, the construction industry is nowhere near to operating similarly high-tech production lines. In our view, fabrication is lagging behind because the industry produces only industrialised, semi-finished products. Modular construction, of course, is part of the timber construction industry and creates a lot of wealth locally, although there are too few companies offering it at the moment. This lack of competition makes the technique less competitive. Carpentry firms are, unfortunately, much too small to drive this innovation forward. The small numbers of units produced by the prefabricated house industry and the numbers of companies filing for bankruptcy emphatically underline the difficult starting position.



I can only share my knowledge of timber construction by conveying a reflection of it. In other words, I have to inhabit, live with and understand a wooden house myself.

#### **4. What areas will provide the greatest challenges to the construction industry in future and what role can a material such as CLT play?**

In the area of sound insulation, we are continually encountering limits in the use of CLT. The same applies to leaving wood exposed to view. If I use wood and it has to be clad to satisfy fire protection requirements or obscured with a suspended ceiling to optimise sound insulation, then wood as a building material becomes less interesting. Exposed wood is very well accepted by users and the material does not have to be immediately associated with farmhouse style decor. Unfortunately, restrictive building regulations are often an obstacle to the appropriate use of wood. In Vienna, for example, internal firewalls cannot be built on external firewalls and the industry cannot offer any usable solutions to this problem. The low weight of CLT, on the other hand, means it is popular for adding roof storeys.

CLT would be used much more often if the industry could provide technically mature solutions to shorten the protracted path to satisfying the building authorities. In tower blocks, wood is used with concrete in hybrid construction materials but that is not yet the final word. CLT will only become more widely used when designers are able to act with more certainty. With clients, we have the following dilemma: “If we provide sound insulation, will the price still be OK?” However, we can certainly deliver speed of construction! However, usability would be guaranteed if we did not have to worry about a potential tier of clients that associates timber construction with barracks or old-style houses; in other words, buildings that have been constructed cheaply.

How can you build quality? CLT works incredibly well as a solution for housing migrants, but there is always the danger that it will pick up an image of cheapness, because savings have to be made on these buildings and the emotive pressure from the politicians is “It has to be a barracks.” This is completely counter-productive, but CLT per se would be a brilliant product.

What we need here are several showcase projects in which the client can be reassured, people can visit and experience a timber building for themselves. For example, by renting out a timber hotel room and staying the night there. After all, there are some buildings that have been constructed so cheaply that they are very likely to conjure up the familiar negative image of noisy neighbours. This quality of building makes a very poor example.

Some housing projects have been built that could not be reasonably described as working well. Every project built by Stora Enso is occupied and therefore cannot be put to the test by potential clients, nor can I modify these buildings to tempt further clients. I can only share my knowledge of timber construction by conveying a reflection of it. In other words, I have to inhabit, live with and understand a wooden house myself. People in general cannot relate to technical parameters in isolation. They have to experience the feel-good factor and set foot in these buildings.



The restaurant in the Naturfreundehaus Knofeleben

”

The job of the industry is to foster technical innovations. Only the industry is in a position to do this.

The industry needs a go-between, a supportive mentor – a role that we building designers would be glad to assume.

**5. How would you assess the cooperation between science and industry, with particular regard to making timber construction viable for the future?**

Carpentry firms are too small to make a meaningful contribution. The industry, on the other hand, is too remote from the end customer. The levels between are unfortunately too ineffective. In my opinion, the architect is quick to adopt proven system solutions. The job of the industry is to foster technical innovations. It should ensure they have a sound regulatory footing by engaging in targeted lobbying and publishing test reports.





Photo: Bauwelt

Only the industry is in a position to do this. But when new building legislation restricts the use of wood-based materials, such as in Upper Austria, then obviously someone has been asleep during these political developments, which I completely fail to understand. In our less satisfying general contractor projects, we often encounter construction firms that win the contract and immediately want to change the building system, because they are not as comfortable as they would like with timber construction. Therefore we need general contractor carpentry firms, which are few and far between on the home market. The larger firms are organised in separate departments, which limits them acting together. Basically, timber construction wins only because the client would like to have it, which is, however, little consolation.

## **6. Would you like to comment on anything we have not covered adequately?**

I see an opportunity for CLT now that industrialisation is able to deliver more individualised products. Rectilinear shapes should not be a priority objective of an economically efficient concept for the use of a timber construction system.

CLT must break out of spatially simple cubic building forms. The reason for this is that wood as a building material is best suited for three-dimensional shapes and should therefore not be relegated to a purely two-dimensional panel construction system. Therefore timber manufacturing technology needs a large injection of innovation.



**Georg Guntschnig** is a product manager with years of experience in building with wood. His focus is on the further development of CLT construction. He has already helped to get several ideas off the ground with innovative approaches and new ways of thinking. He acquired the requisite know-how at Campus02 in Graz, where he completed a part-time degree in innovation management. In his master's thesis, he took a look into the future of timber construction with the aim of identifying possible development potential in cross laminated timber (CLT) technology. Excerpts from the thesis are included in the study and were also the basis of a deeper discussion of this exciting and brand new subject.

# Technology and Innovation

## Wood – a construction material for the 21<sup>st</sup> century

Wood is one of the oldest materials used in construction. For a long time, this raw material was the most cost-effective and simplest method in our latitudes for building anything (house, utility building etc.). What was – and still is – the most common way of erecting a building was based on this universal, natural material. When we decide to build a structure out of wood today, it is, of course, essential to comply with the applicable general regulations (construction and safety requirements). However, we can also thoroughly explore the enormous technical and architectural range of possibilities that have been developed in timber construction over the past decades. At first sight, this might appear to be an onerous task, but the pressure comes only from the diversity of options that building in wood brings with it. Not surprising, this opens the way to individual concepts designed and constructed to meet the client's specific needs.

Wood is often deliberately used as a visually exposed element, where it usually makes a clear statement of the ecological, modern and energy-efficient credentials of a building. Accordingly, it can be argued that wood also actively contributes to climate protection because, as the natural material grows, it absorbs CO<sub>2</sub> from the atmosphere and locks it away. Wood is a sufficiently available and renewable resource that can be completely recycled or disposed of in an environmentally compatible manner.

Another of the material's strengths is that building with wood is a straightforward, dry process that requires little working space. Timber construction is characterised by its negligible weight compared with, for example, brick, masonry or concrete. In the same way, timber walls are thinner but provide the same building physics performance and a timber building takes next to no time to dry out. This advantage is a result of the high degree of prefabrication in the production facilities, where whole components or even structures can be produced to precise dimensions under controlled conditions and protected from the weather. They are then carefully delivered directly to site and installed in accordance with the standards.

In earlier times, it was not unusual for the danger of fire in timber buildings to make people feel unsafe and uneasy. Since then, the building codes of practice have changed immensely and the regulations governing building use and construction have been amended. As a result, living in a timber house is now considered completely safe. The same applies to the durability and structural stability of timber buildings, as long as the design and construction conforms with the applicable regulations and standards.

## Technologies in changing times

The advance of technology cannot be halted. New types of product and services are rapidly changing our activities and

## Technologies as drivers in the business model

This innovative industry model focuses on cross laminated timber technology and considers the wealth creation process on three different levels.

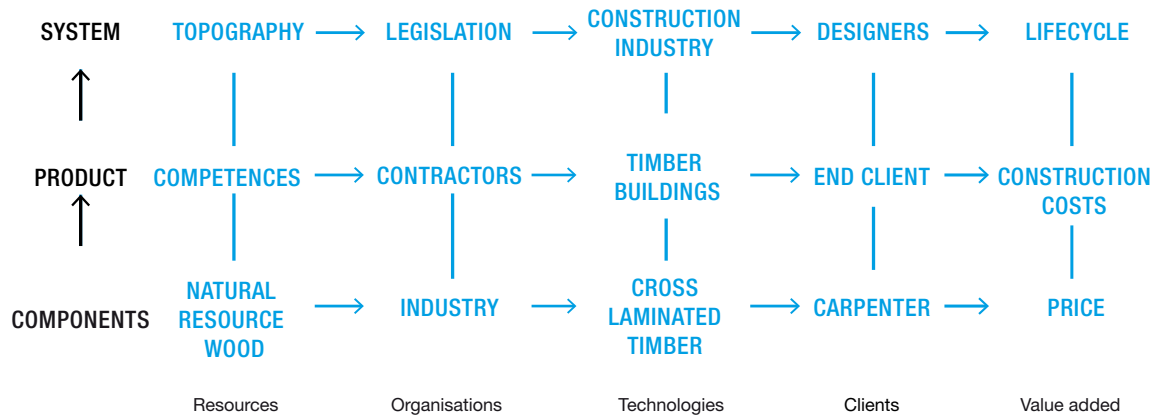

Source: Master's thesis "The future of timber construction", Georg Guntschnig, MA

also result from this interesting spiral of development. Companies are subject to enormous pressure from global competition. The present business model is usually short term and needs continuous adjustment in reaction to the need to fulfil constantly changing customer requirements. In addition to the necessary competencies and resources that form the basis of a successful business, it is even more necessary to keep abreast of the progress of new technologies and their possibilities, in order to judge the merits of future strategic fields of business. Continuous monitoring of the market and technology is seen as a key element in any strategy for the further development of the Stora Enso product range. Cross laminated timber (CLT) is, without doubt, one of the promising technologies in the timber construction segment of the wood industry. This technology has opened new doors to multistorey timber construction, which is reflected in the continually increasing market demand.

An outstanding example of the clever application of innovative technology at the highest level can be drawn from the work of the British consumer electronics company

**Dyson.** The company's consideration of air flows and how best to harness them has revolutionised fan technology and has led to a completely new product. By applying the principles of physics, Dyson developed and marketed a fan that fulfils the customer's requirement for a cooling airflow without the need for blades (see below).

This designer product, which uses less of our natural resources, has triggered customer enthusiasm and generated higher sales to boot. This unparalleled approach clearly relies on comprehensive knowledge of the market and technology.



Photo: Dyson

## Frame – post & beam – solid timber: Housing construction methods

Timber construction methods in housing and their possible combinations

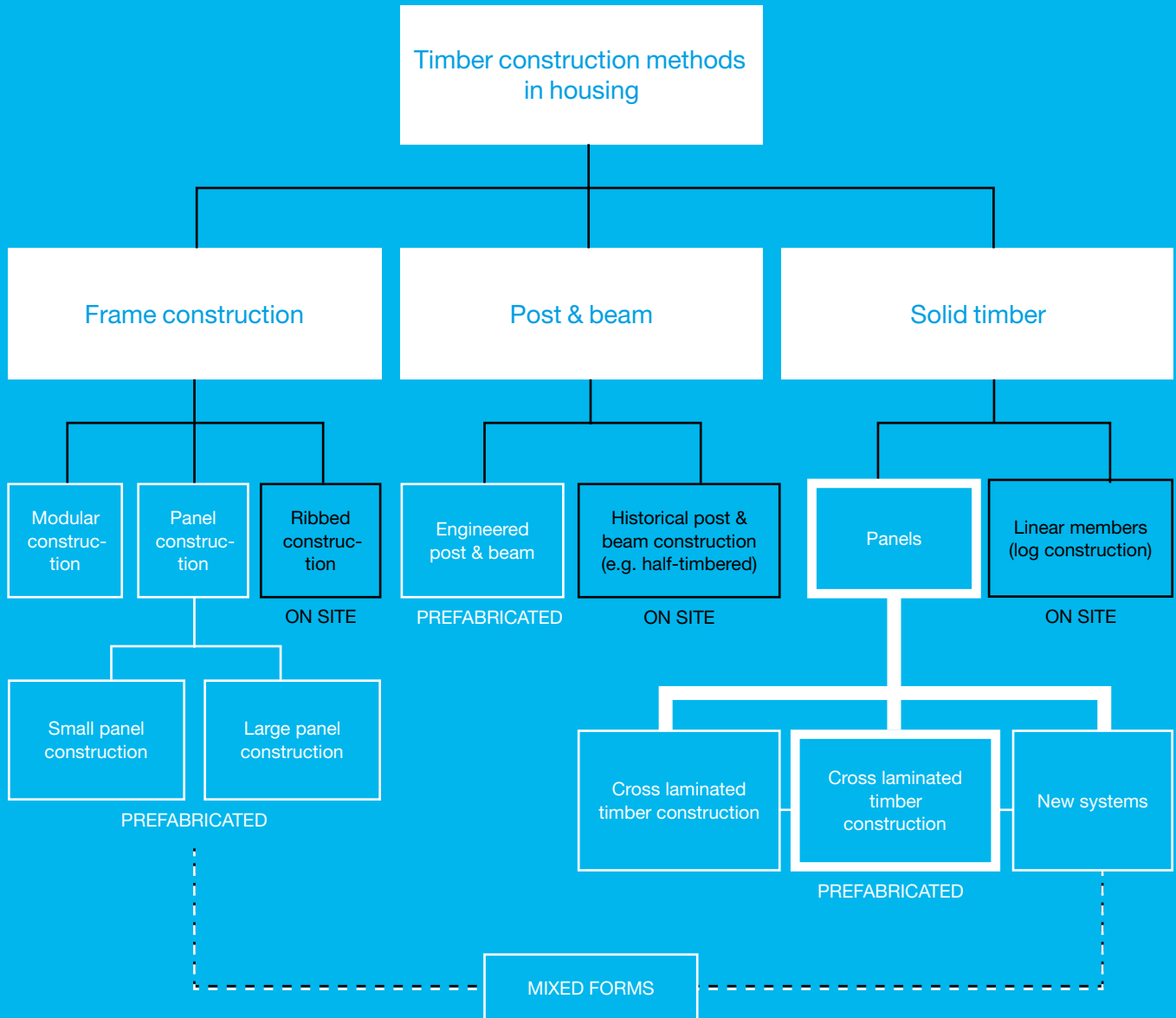

The various construction methods referred to in the building industry often take their names from the process by which the elements are put together to form a loadbearing structure. A major distinction is drawn between solid construction and lightweight construction. Very often, solid construction refers exclusively to masonry, brick or concrete. However, if these two major types

of construction are considered from a neutral perspective in terms of materials, then they could be combined with a wide range of materials, for example, a combination of solid brick construction and solid timber construction. A more detailed consideration of timber construction differentiates between three important technologies, namely frame, post & beam and solid timber.

# What's next?

## Timber construction's technology spiral

### Hybrid construction

In mixed construction with reinforced concrete, circulation cores containing the staircases and lifts are often built of reinforced concrete. Wood-concrete composite floors allow long spans and thinner floor depths in office buildings. They also have good sound insulation and fire protection properties.

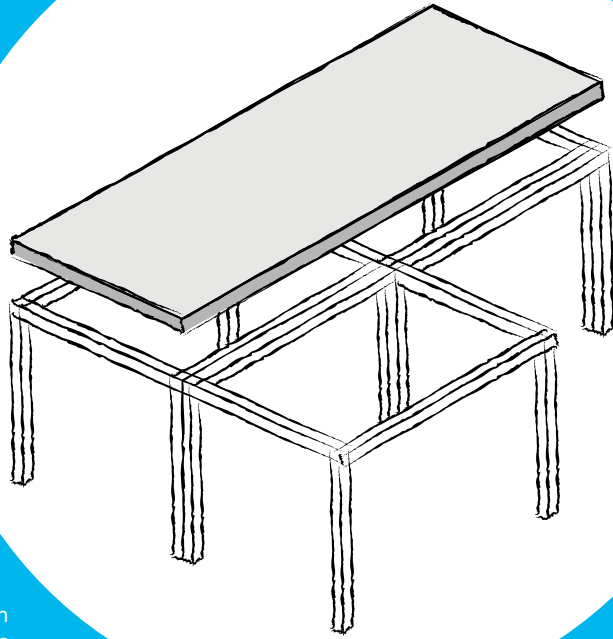

The building material wood and the various technologies in timber construction are currently experiencing a renaissance. Cross laminated timber technology opens new doors and possibilities never available before and not yet fully exploited. Looking at what Dyson has achieved, there is surely plenty of scope for timber construction to grow. How the approach to the new technologies is implemented by the companies involved in the industry will be crucial to its success. In setting their objectives, product development departments should focus on the following thought: "We do not wish to produce a special timber component, we would rather make a crucial contribution to creating sustainable, healthier and more affordable buildings."

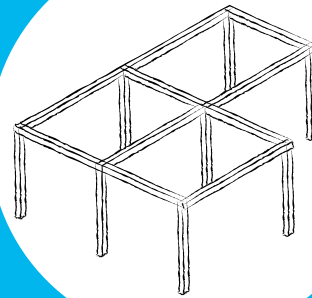

### Timber post & beam

The loadbearing structure is reduced to a minimum, which provides for maximum flexibility of floor layouts and freedom in the design and positioning of the façade openings. The insulation and loadbearing functions are separated. Replacement and demolition of components is made easier, while material use is minimised and the weight reduced.

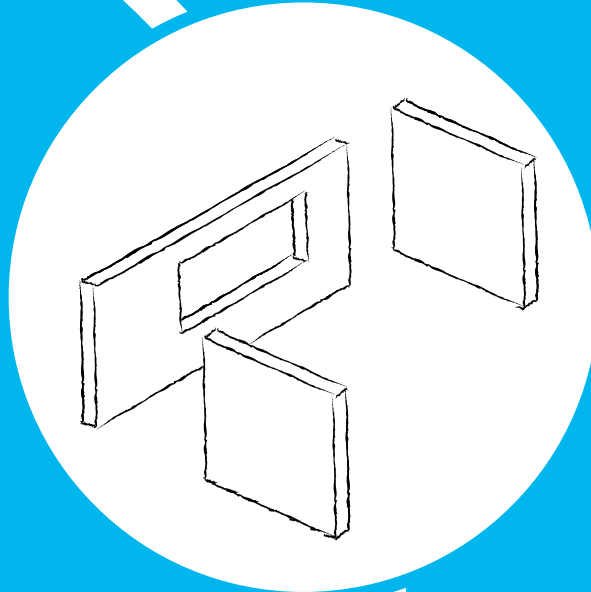

### Solid timber construction

The main systems in solid timber construction are cross laminated timber (CLT), dowel laminated timber (DLT) and log building construction. They are used mainly for walls and ceilings. The buildings have a high thermal storage capacity and monolithic members with very few individual layers. The load-bearing elements can be left open to view. The cavity-free construction has fire protection advantages.

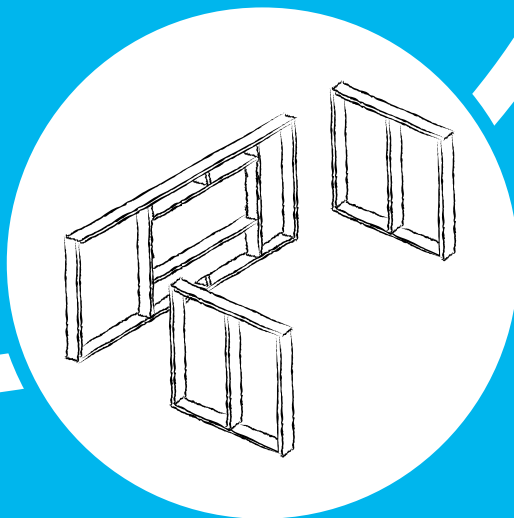

### Timber frame construction

The components provide a high standard of thermal insulation and are largely free of cold bridges. Extensive pre-fabrication results in shorter construction times and better build quality. Walls may be designed to be loadbearing or stiffening.

# Timber Construction's Future Radar

What trends, factors and technologies will affect the future development of timber construction?

Timber construction's future radar displays present and future fields from a wide range of different areas of timber construction and reveals that there is a lot of scope for strategic orientation.

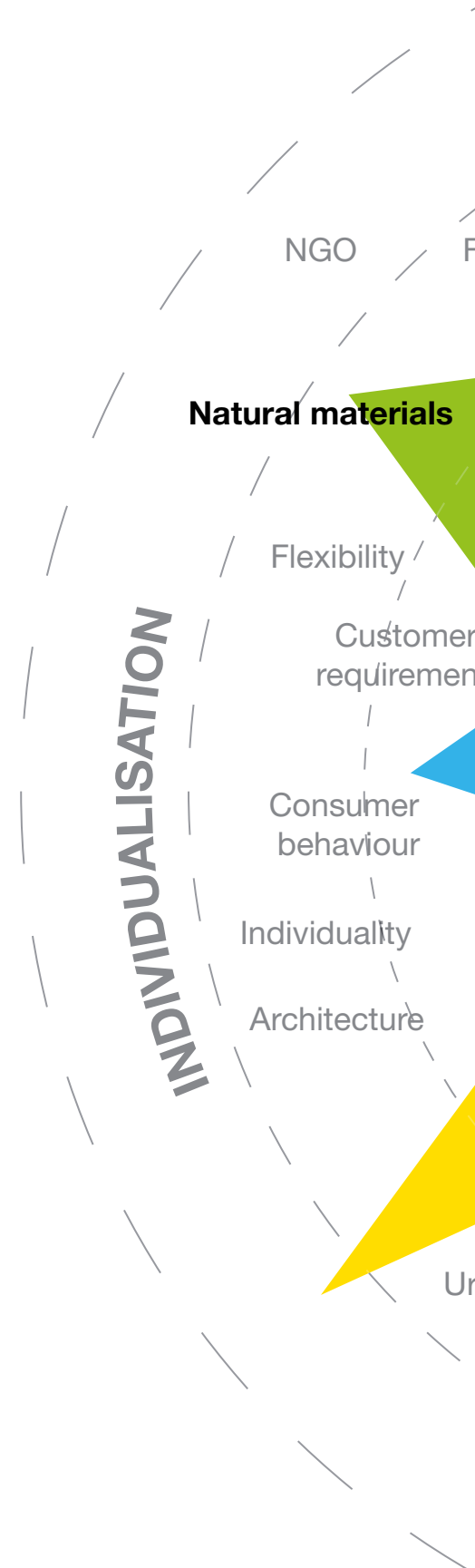



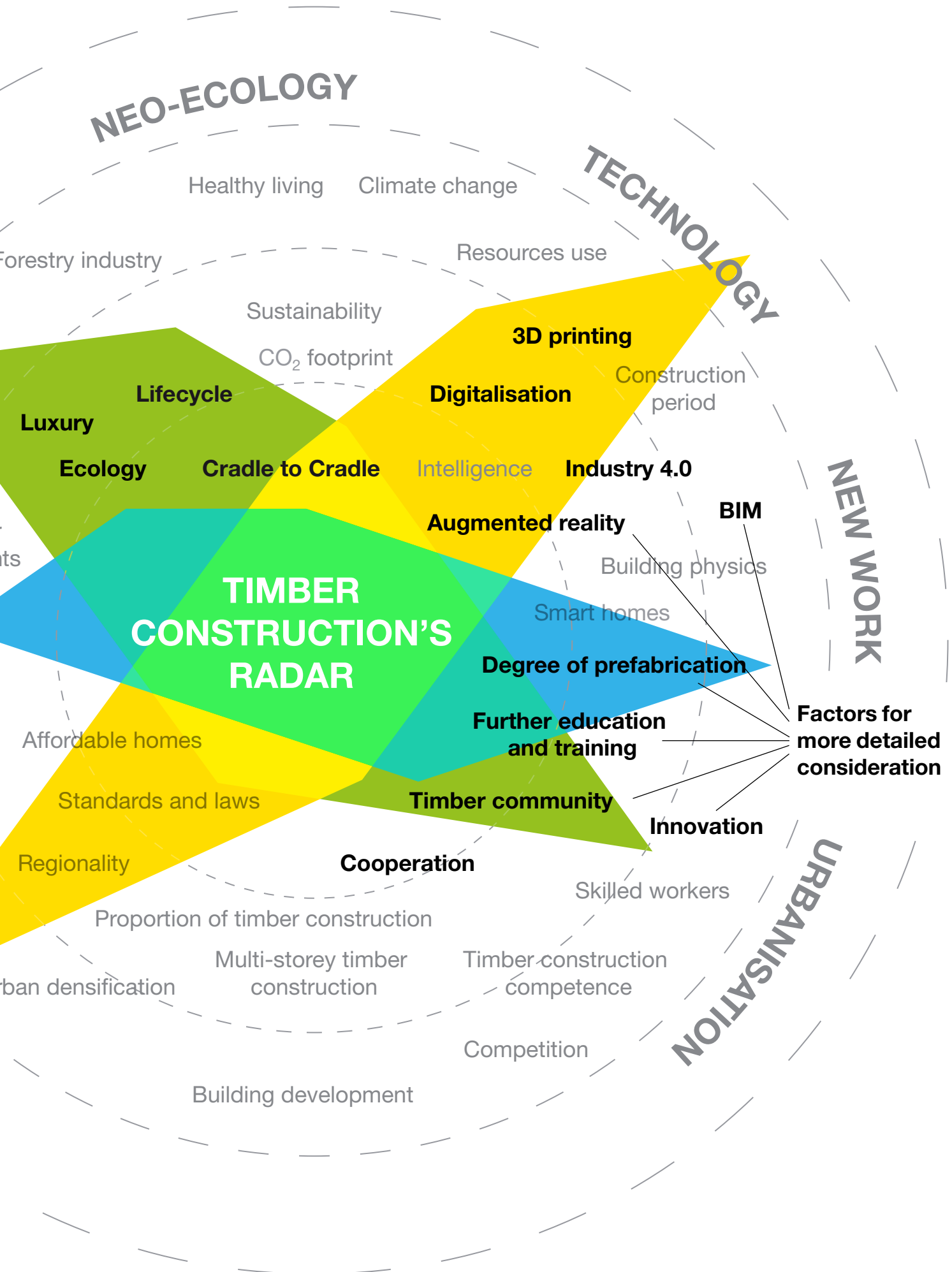

## The ecology factor: moving from green to blue

In his book “The Blue Economy”, Belgian entrepreneur and visionary thinker Gunter Pauli has put together a collection of his many thoughts on Blue Ecology. The following elements distinguish blue from green ecological thinking:

→ Abandonment of nature romanticism: Mother nature is neither “sensitive” nor “precarious”. She is a robust, resilient, adaptive system of which humankind and its activities are a part.

→ Surmounting the “green vs. evil” polarisation: The establishment of a “green counter-sector” does not go far enough. Bio products in the food, drink and clothing sectors remain available only for a small, rich elite and change nothing in the damaging overall system – and are unsuitable for fighting poverty. Transformation can be successful only if the “conventional” itself takes on a new logic.

→ Globalism: Radical globalisation profits only those regions in which living conditions have an established, stable base. Blue ecology therefore seeks to generate as many processes as possible using regionally available raw materials. Even regions with few raw material resources have many different opportunities in this scenario, because the possibilities of conversion are continuously increasing. For example, paper can now be made from stone, fuel from thistles or shoes from coffee fibres.

→ Evidence-based ecology: What is now standard in the medical sector, should also apply to the ecology debate – evidence-based thinking and analysis. When considering the goal of avoiding CO<sub>2</sub> emissions, it is helpful to remove some rather marginal effects. It is many times more efficient to preserve rainforests than it is to insulate old houses using environmentally

## Old “green” ecology

1.  
Resources and energy are scarce.

2.  
Nature is sensitive.

3.  
There are too many people.

4.  
The Earth is a closed system (space ship).

5.  
Change is driven by guilt.

6.  
Crises are signs of demise.



## New “blue” ecology

1.  
Resources and energy are basically infinite.
2.  
Nature is a resilient system.
3.  
People are wonderful.
4.  
The Earth is an open system. (Adaptive self-organisation).
5.  
Change is driven by possibilities.
6.  
Crises are self-corrections of systems.

harmful materials. Functioning CO<sub>2</sub> markets are more effective than switching off a modern coal-fired power plant.

→ Overcoming technophobia: Technophobic beliefs with ideological undertones often underlie ecological mindsets. But technology must not be “restricted”, it must be unleashed in other ways

→ Bio-genetic engineering: the most potentially explosive rift between green and blue ecology can be found in bioengineering. Cis-genetics (the Latin prefix “cis” means “on this side” – of the species barrier in this case) blurs the line between breeding and genetic engineering. Using this new process of precise gene editing (CRISPR), natural mutation processes can be radically accelerated. Tomatoes that both taste good and resist rot can now be “built” in the laboratory. The crucial aspect of cis-genetics is that it does not combine genes from different species to create “chimera” characteristics. Instead, only species-specific crosses are made – apples with apples, chickens with chickens, tomatoes with tomatoes – and optimised. Everything the technique produces could have come about randomly through natural evolution.

This method of controlled evolution demolishes the argument that all such processes are dangerous. However, cis-genetics exposes an ideological red line: for people who oppose genetic engineering, the primary issue is not one of danger but rather one of principle: “Man should not meddle with nature.” However, this is exactly what humankind has been doing naturally for thousands of years through farming and stock-breeding, vaccination, or purely by existing on Earth.

Saying farewell to scarcity logic is crucial to this new ecological modernism: we live in times of abundance, which we can utilise, magnify, moderate or improve (which does not mean that distribution problems can no longer arise). Scarcity comes about only in unintelligent design.

## The construction materials of tomorrow factor

The requirements of the materials of tomorrow are becoming increasingly complex. New discoveries in the fields of nano, bio and information technology play their part in driving the development of materials for future products that are not only customised but also smart. Packaging that decomposes in three weeks into biomass, which in turn can be used to provide heat or cooling depending on ambient temperature, or surfaces that are resistant to scratches and dirt are

but a few examples. The trend of using environmentally conscious materials is increasing just as fast as the desire for achieving low self-weight through the optimised use of materials, or to recycling and environmental compatibility.

The right choice of construction materials will become increasingly important because the energy used to create a building is approximately the same as the cost of heating a low-energy house for 50 years. Environmentally compatible construction therefore seeks to use the best possible thermal insulation, renewable energy carriers and ecological building materials. Choosing to use ecological materials reduces the pressure on the environment and our wallets in a sustainable way.

### Solid timber construction best protects the environment

Comparison of construction materials and their environmental effect, Eco Index 3 (OI3)

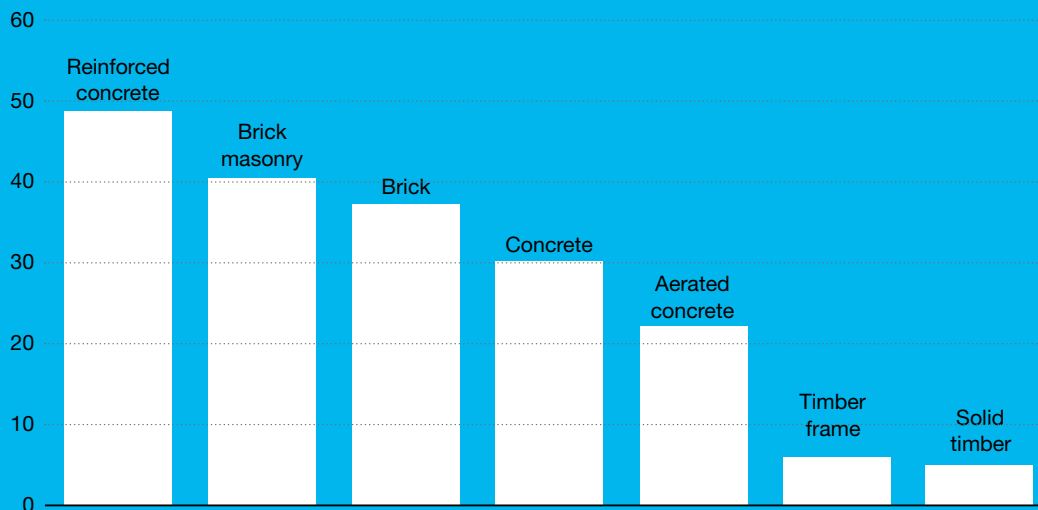

The chart shows  $\Delta$ OI3 values (Delta OI3) for typical thicknesses of some construction materials. The calculation relates to the manufacturing phase. The  $\Delta$ OI3 value indicates the value of the ecological Delta (i.e. the influence on the environment) of a single layer of the installed construction material.

Source: Ökoindex3, baubook.at

The chart shows that a typical thickness of concrete alone does not come off too badly in the OI3 system and that the reinforcement has a significant effect. The mortar in a brickwork wall attracts approximately three  $\Delta$ OI3 points. Aerated concrete used e.g. in walls and floors has a very good  $\Delta$ OI3 value. However, the best  $\Delta$ OI3 performance is recorded by solid wood because of its high CO<sub>2</sub> storage capacity.

## The quantitative comparison of construction materials in accordance with OI3

Energy is used in the manufacture of building materials. Greenhouse gases and pollutants are released, for example from chimneys. The objective is to use building materials with the least possible environmental effects. The Austrian Institute for Healthy and Ecological Building (IBO) focuses on this issue and offers advice and assistance in the selection and comparison of an extensive range of materials. An important indicator, Environmental Indicator 3 (OI3), evaluates the ecological quality of all materials in the building shell (façade, roof etc.) based on three important environmental criteria:

- **Primary energy input (PEI<sub>ne</sub>)** – Non-renewable primary energy for manufacture
- **Global warming potential (GWP)** – Global warming by greenhouse gases
- **Acidification potential (AP)** – Local effects on soils, woodland, watercourses etc.

The base data is kept up-to-date in the "Baubook" (building book) ([www.baubook.at](http://www.baubook.at)), which lists and evaluates a multitude of materials from a wide range of companies. The evaluation process is described in the OI3 guidelines published by the IBO in Vienna. The choice of building materials should be based on products that require little energy for their manufacture. This means that materials requiring a great deal of energy to manufacture, such as metals, reinforced concrete, plastics, waterproofing membranes etc. should be reduced to a minimum or used only if their technical advantages are considerable and no other method of achieving the same result is available. Most construction materials made from renewable resources impose a particularly low ecological load. They can be used in the loadbearing structure, thermal insulation, façade, interior fitting out etc. Such materials include wood, reeds, straw, flax, hemp, sheep's wool etc. These building

materials are not only environmentally friendly, they also often contribute to a healthy indoor climate.

## Principles of choosing construction materials

If the following principles are followed when making the choice of construction materials, then their influence on the environment will generally be lower and the OI3 index optimised.

- Construction materials consisting of renewable or regenerative raw materials
- Construction materials consisting of recycled material
- Materials requiring low amounts of energy for their manufacture
- No products containing dangerous substances
- No products with pollutant emissions
- Long-lasting products
- Easily disposable (recyclable) products

## Lifecycle optimisation of buildings

The evaluation process described above can be used not only for evaluating the manufacture of construction materials, but also for a wide range of other applications. For example, it could be used to model the energy required to manufacture building services equipment, transport to the construction site, replacement of component layers, building use right through to the demolition and disposal of buildings.

This novel method is an important piece of the jigsaw in the quantification and comparison of materials. It is of enormous relevance not only for investors, but also for any required official certifications, such as for obtaining housing grants or various building certificates.

## The lifecycle of a building

Income and expenditure over the course of time

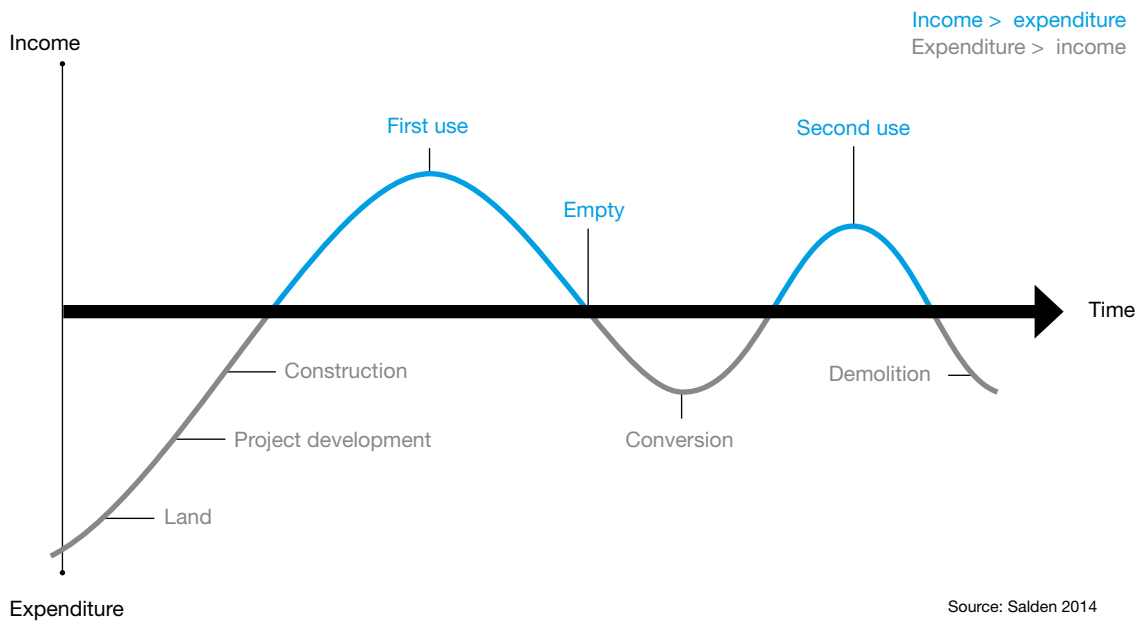

## The lifecycle of buildings factor

The economic analysis of buildings is not always easy to comprehend because the evaluation criteria are not transparent to people not directly involved. So that the economic value of buildings could be calculated and used to best effect, George Salden developed a dynamic method of building economic analysis that is diametrically opposed to conventional analysis models, which are based on static criteria and exclude market dynamics. The successful transactions manager was interviewed on this subject by the Zukunftsinstitut for the Immobilien Report 2016. George Salden is CEO of Arbireo Capital AG and has worked in the real estate sector for over 10 years.

The dynamic method for the economic analysis of buildings offers a way of evaluating a building in its entirety and its context, including its environment and social

developments. This method evaluates the building not in isolation, but within the overall context of everything that could affect it. Up to now, the industry mainly used evaluation methods based on the discounted cash flow (DCF) method. These consider the location of the building, including its lifecycle and rental income, to be an important factor in the calculation of the economic value of a building. The dynamic method, on the other hand, recognises that the people paying the rent are also a factor to be taken into account. People are subject to natural cycles, dynamics and fluctuations that cannot be simulated in static models. The market and the building are not evaluated at a fixed, specific time but modelled using big data in terms of the various cycles and their potential.

The cost calculations in the dynamic method combine various datasets and factors, which makes the results of the analysis completely transparent and justifiable. In addition to potential rent increases over the period of use, the costs of managing

## Useful life of different types of buildings

The more investment in the usage phase, the longer the useful life of the building

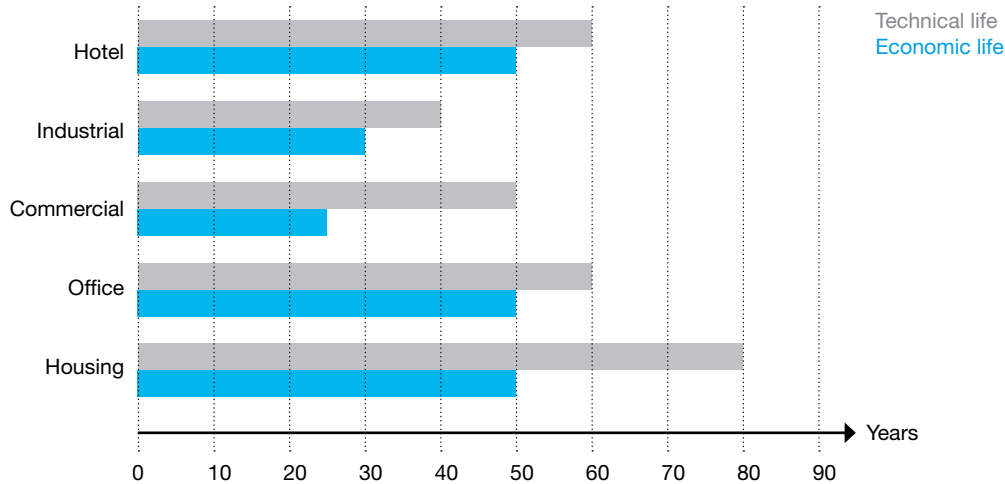

Source: Salden 2014

the building, the costs of increasing rental potential and the sale of the building are taken into account. The large quantities of data allow conclusions to be drawn about the cost per square metre to be set aside for maintenance. The costs of changes of residence, fluctuation rates, financing, asset management and insurance are measurable. A business plan with up to 80 parameters is prepared. It is based, as far as possible, on verifiable figures and is therefore very low risk. Big data allows the user to identify realistic opportunities and new markets because the method shows the position of the building in the market or where it deviates from the norm. The large quantities of data, market analyses and automatic calculation procedures provide insight into the best possible capital cycles.

This microcyclic analysis uses tools that other industries have exploited for many years: the Internet, intelligence and automatic linking to a wide range of datasets. Qualitative factors such as urbanisation, centrality, degree of

natural surroundings and the status of the location are also taken into account. Using algorithms, it is possible to calculate the point at which rental income is optimum because the method takes into account the actual rental cycle applicable to the building. The possibilities of increasing these cash flows are modified to suit the legal position and market rents. Algorithms can also access the stored cycle data pool to calculate cycles from past and present data. Prognoses of the future dynamic value of the building can be made from these trends. They are not only transparent and realistic but also identify any possible potential.

George Salden recommends counter-cyclic investment in buildings that have come to the end of their usage cycle and can therefore be redeveloped and institutionalised. The investors start with not only a value at a point in time and presumed improving gross returns, but also dynamic trends. Once the positive and negative trends become apparent, investors can adjust their actions accordingly.

## The BIM (Building Information Modelling) factor

The age of digitalisation has been with us for some time and many different industries have already structured their business around it. The building industry is also undergoing change and has recognised that creating the building is no longer the main factor. In future, taking the whole lifecycle of a building into consideration will be far more relevant. The collection of information and project data – starting at the preliminary design stage, continuing through construction and use, right up to conversion and demolition – presents new challenges for the industry. The use and integration of existing digital technologies, such as those already adopted in other sectors, is the key to success, and will initiate new patterns of thinking in the building industry.

Building information modelling (BIM) is a technology that has become enormously important in the building sector because of the digitalisation trend. In addition to taking the purely physical properties of the building into consideration, BIM creates a digital model, which accompanies the building over its complete lifecycle. The model could be described as the building's "brain" in which all the building's information is stored or recorded and can be recalled at any time.

When considering the value of BIM, it is important to realise the usefulness of not only all the information and data from the design process, but also the opportunities and possibilities it offers during the usage phase and for the demolition of the building. Which components are structurally necessary in a conversion? When is the next maintenance of the component due? What is the energy consumption of the building? What natural resources are stored in the building fabric? These are some of the questions that can be answered if a building project has been completed using BIM technology. The degree of detail adopted in the application of BIM has an influence on the answers. A total of six levels in a building information model can be queried,

depending on the information they hold and the consistency of application. There are a number of types of BIM (maturity levels):

- 3D BIM: Three-dimensional representation of the building project
- 4D BIM: Integration of the construction scheduling into the 3D model
- 5D BIM: Cost planning and cost management of construction work or the whole project
- 6D BIM: Information for the maintenance and operation of the building

Many innovative architectural offices or large construction firms are already working with BIM technology. The international picture sees countries such as Singapore, Finland, the USA, Australia and the UK as pioneers in the introduction of BIM technology. The state or various public bodies are the main drivers of the introduction of BIM in these countries. For example, the British government has set itself the target of cutting building costs by 15% to 20% and reducing CO<sub>2</sub> emissions by 50% through the use of BIM technology.

### BIM and timber construction

After a more detailed consideration of the methods used in designing and building timber structures and linking this knowledge with the basic principles of BIM, it soon becomes apparent that some aspects of timber construction are already an integral part of this technology.

Many architectural offices and timber construction companies are completely familiar with handling three-dimensional building data. Automatic determination of quantities and bid preparation or the further processing of digital data on CNC joinery machines are already everyday routines. The cross laminated timber industry is so far developed that, for example, data can be taken directly from external design offices, prepared and input straight into automated production plants and the finished components delivered to the building site.



**Building Information Modelling: from design to demolition**

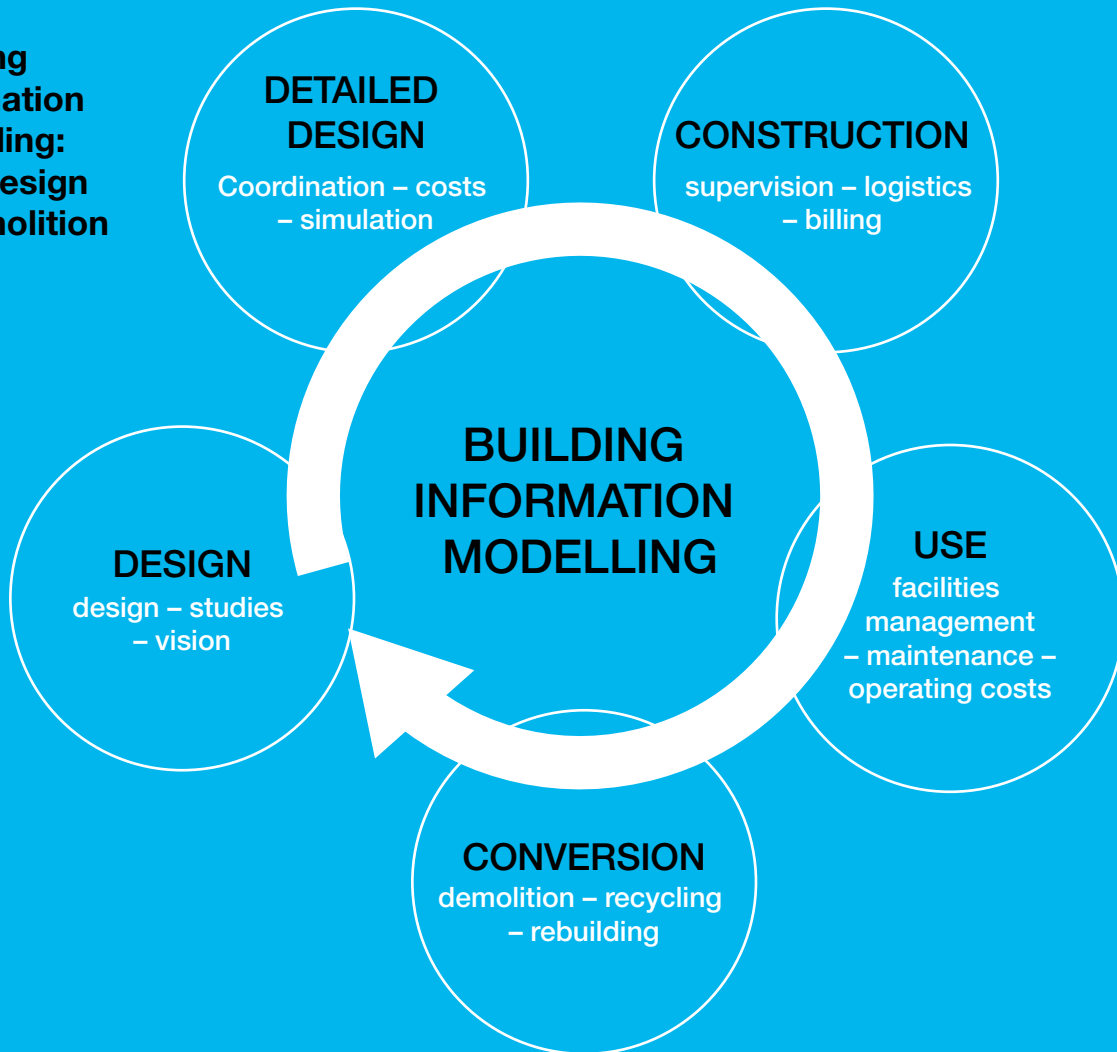

<b>Concept design</b>	<b>Detailed design</b>	<b>Use</b>	<b>Conversion</b>
<p>The basic idea for the proposed construction project is drawn up and used for creating one of the first digital models. This enables the designers to check that individual buildings or parts of buildings do not interfere with each other and allows interdisciplinary cooperation between the architect and client from the start of the project, irrespective of where they are based. Work begins on a model at a very early stage and therefore avoids the costs of later changes in plan.</p>	<p>The more advanced digital model opens the way to simulations to determine heating requirements, lighting scenarios and the structural engineering design of individual components. This precise quantity survey is of advantage in cost estimates and for the later preparation of specifications for the tender.</p> <p><b>Construction</b> The digital building model allows tenderers to calculate costs more precisely and submit more accurate bids based on a much more detailed picture of the work involved. Being able to look at building components like this and consider the time window available for manufacture creates advantages in the coordination of work on site. It also contributes to more effective site supervision and defect management.</p>	<p>Handing over a digital model to the client or investor with detailed construction records provides a valuable link to the future facilities management of the building and gives important information for its operational phase. Information about room sizes, electrical and building services connections, and the maintenance and warranty conditions of the components used help to prolong the useful life of the building.</p>	<p>Converting buildings to make them suitable for a change of use is much simpler to accomplish following a procedure based on the BIM model and the higher quality information it makes available about the building. The demolition and environmentally compatible recycling or reuse of components at the end of the building's life is much easier when based on knowledge of the materials used in the construction of the building contained in the BIM.</p>

Source: Building Information Modeling, Technologische Grundlagen und industrielle Praxis, VDI

Working with 3D data is well established in the timber construction industry. This knowledge and the use of experience in the integration of BIM technology must be seen as an opportunity for timber construction. Producing a 3D model of a structure alone is not enough for the company to call itself a BIM user. Not only must working methods and processes to be modified accordingly, but solutions also need to be further refined in terms of data exchange and cross-platform software capability. It will be critical for the industry that the companies involved become completely familiar with BIM technology in detail and commit the appropriate resources. Companies such as PORR AG, Hilti and Strabag SE can justifiably claim to be showpiece enterprises in this field. The commitment of all parties in the construction process and effective interdisciplinary cooperation in projects are the ultimate benchmarks that are driving the future success of BIM technology.

When all the factors discussed here relating to this new form of technology are considered together, it can be said with certainty that the sort of building projects for the digital world we find ourselves in today are hardly imaginable without BIM. The level of detail is decided based on the project requirements. In order to assume an important role as a project partner in building the construction projects of the future and adequately fulfil the wishes of the investors, it is essential for an organisation to integrate BIM technology into its own value-added process, a requirement which is also crucially relevant for its future business.

## The Industry 4.0 factor

The age of digitalisation and the intense pressure of global competition demand a complete rethinking of the manufacturing processes of products and services. They present companies with completely new challenges, but also offer enormous potential opportunities and confront management with the need to introduce further actions sooner rather than later. The networked communication of resources, information, projects and people is no longer stoppable. A new era has begun and its effects at the industry level will be like those of the Industrial Revolution. Industry 4.0 sets the smart factory at its heart and surrounds it with new services. Everything will be smart and connect the Internet of Things with the Internet of Services so that products will contact the factory direct from home in future.

### The technological drivers of Industry 4.0

- **Cyber-physical (production) systems:** Systems composed of networked devices, machines and mobile objects that, for example, communicate over the Internet.
- **Big data and data flows:** Networked communication gives rise to data flows of unimaginable size, which it needs in order to work. The networking and analysis of the data forms the basis for the development of new data and the foundation for the sustainable handling of resources.
- **Cloud technologies:** Allow access to the centrally stored data, which are available at any time and from anywhere.
- **Additive manufacturing processes:** 3D visualisation and 3D printing play a central role here. These technologies allow complete individualisation of products and are tailor-made to the needs of customers.

## Industry 4.0 in Europe

Digitalisation will change processes, production, products and services enormously – also for industry. According to a study published by PWC AG and the German Federal Ministry for Economic Affairs and Energy (BMWi), the 17 most important industrial countries in Europe could add around EUR 1,250 billion to the value added to the goods and services they produce by 2025 if companies have organised themselves to be innovative and agile, can rely on appropriate infrastructure and conduct their business in a favourable digital environment. If digitalisation develops positively, Industry 4.0 should add an additional growth potential of EUR 200–425 billion by 2025 in Germany alone. But this leap forward cannot be taken for granted. If Europe is not successful in using digitalisation to its advantage, then for industry alone about EUR 600 billion of gross value added could be at stake. This is the equivalent of a good 10% of Europe's industrial base. The European Union's target of increasing the proportion of industrial output in Europe to 20% by 2020 would therefore be out of reach.

## Industry 4.0 and the timber industry

The most worthwhile place to find a smart factory of the future would be in a sawmill, even though researchers would perhaps state it differently. The vision is clear: the trunk is scanned, for example using computer tomography, after which the sawing and subsequent processing of the wood can be optimised. The data is further processed for the virtual cut timber store, which then opens the door to precise production planning to suit the quality of the available wood and the demand. Another possible application is the precise display of drying data, which could make a direct contribution to production monitoring and quality assurance of the timber products.

## Industry 4.0: History

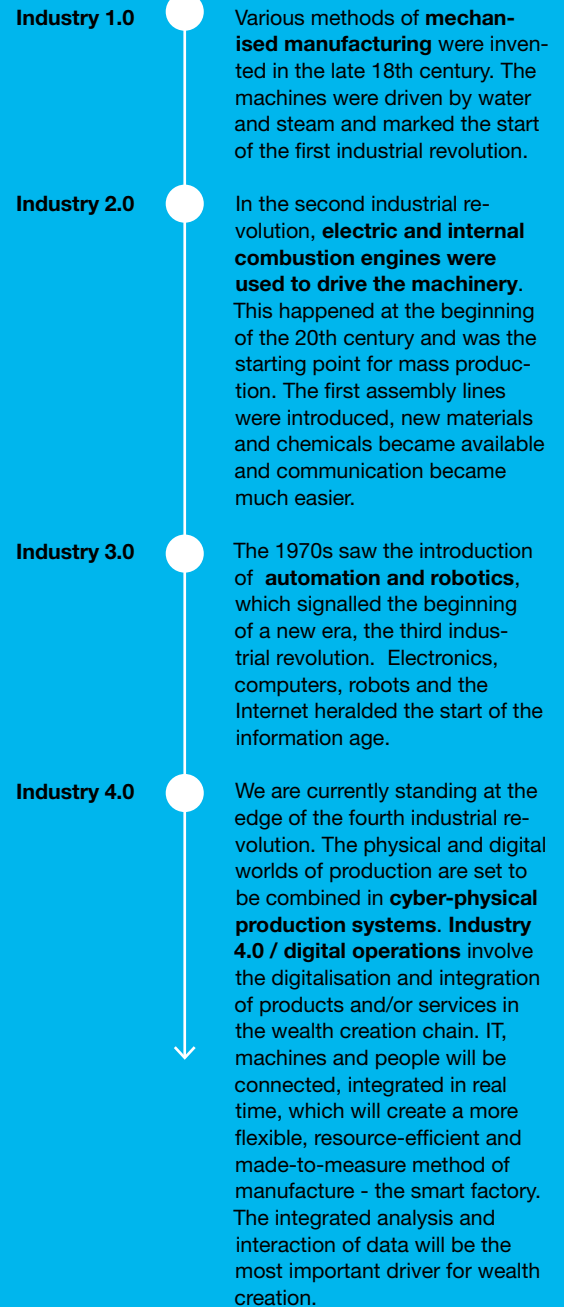

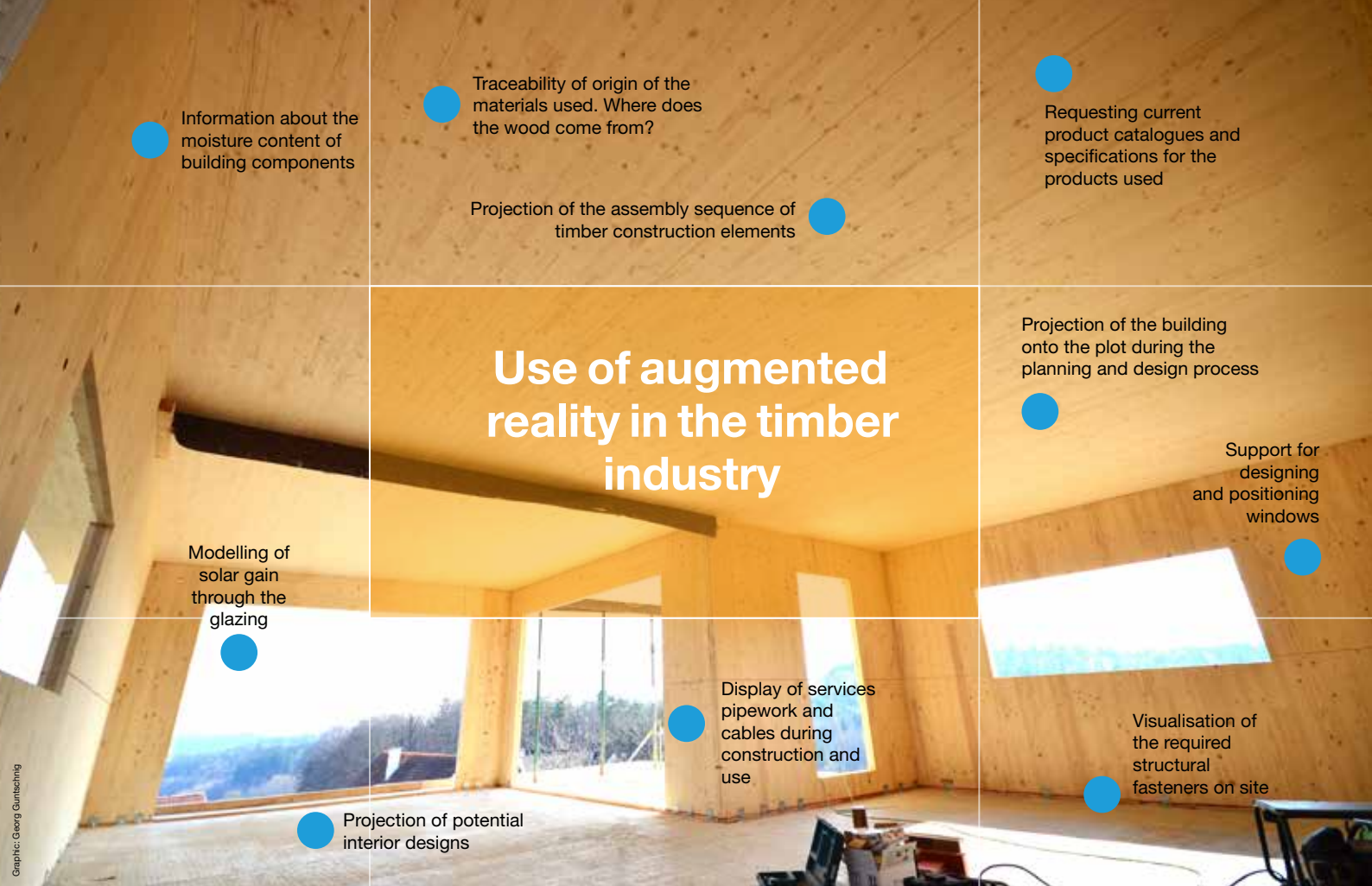

## Use of augmented reality in the timber industry

## The augmented reality & virtual reality factor

In augmented reality (AR), additional virtual elements are superimposed on the real world with the result that people's perception is augmented by additional information. AR applications require three main components: the user, the real physical environment and a display, which superimposes virtual elements onto the real environment. The use of AR is already very popular.

IKEA has used this technology for many years to offer customers the chance to project pieces of furniture in the setting of their own four walls before they make their decision to buy. It is the ideal technology for supporting marketing and presenting the product in unique settings.

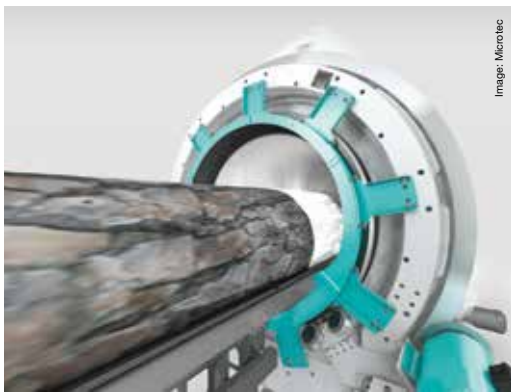

**Microtec CT Log**

A further promising development field for industry 4.0 could be production processes for highly complex, customised articles, which are already in demand today. Best practice examples would include parquet floor manufacturers, window producers and the prefabricated building sector, which can also be envisaged as future target groups for networked communications.

The challenge for companies that wish to use AR lies in the programming of the AR apps and making them palatable to the end customer. "The greatest challenge for the future of this technology will be conforming with the customers' self-image and fulfilling their expectations that they should, or indeed must, have access to information at any time, in specific places or in specific situations," says Dr Georg Binder, research department manager and expert in smart glasses and augmented reality at Evolaris next Level GmbH in Graz.

When considering digital technologies, it is important to be aware of the main differences between VR and AR technologies. Virtual reality (VR) differs from AR technology in that it replaces the real world completely with a virtual world. This allows graphical simulations of a wide range of applications. Microsoft is playing a crucial part in the further development of this technology. Microsoft's HoloLens smart glasses (see below) set new standards in the projection of virtual elements and allows users to immerse themselves in a digital world. The glasses merge the real and virtual worlds. Microsoft uses the term "mixed reality". This technology offers new options in the development of complex projects and for exchanging ideas within teams ([www.microsoft.com/microsoft-hololens](http://www.microsoft.com/microsoft-hololens)).



Photo: Flickr, Microsoft Sweden, CC BY

## Practical application of augmented & virtual reality

The merging of the digital world and our physical surroundings will also be adopted enthusiastically in architecture. Information can be attached directly on the components

or on site by means of highly compact QR codes and then queried and further processed in real time using a wide range of control devices. On the one hand, this would be of interest to sales staff selling property, providing them with a means of taking end customers around buildings on a virtual tour. On the other hand, this technology will also be an important tool in the design and construction of buildings.

Adherence to quality standards on site and the avoidance of errors during construction can be guaranteed in virtual space. A building designed and built in accordance with the BIM principle and created in digital space will coalesce before the user's eyes with this technology, which offers so much potential. In timber construction, for example, installation guidelines and the proper fasteners to use to satisfy structural engineering requirements, cable and pipework layouts for technical building services as well as general information about the building can be called up at any time by the tradesmen on site. The added value delivered by this technology has a direct effect on the quality of buildings, while simultaneously saving time and cost for the investor.

### Possible application scenarios:

- Projection of fasteners and connections for assembly
- Display of cable and pipeline layouts according to the drawings
- Virtual display of installed layouts for re-use
- Querying stored information during the building use phase (source of components, integrated building sensors etc.)
- Projection of the assembly sequence of timber construction elements

## The 3D printing factor

Today, you can manufacture almost anything yourself using a 3D printer – even complete buildings. Should this process eventually become suitable for use by anyone, then we are standing at the threshold of a real industrial revolution. Building a house using a 3D printer requires no input from tradesmen whatsoever. Only a CAD model of the building is required and this is then printed out layer-by-layer by the D-Shape printer. Moreover, the required basic construction materials, sand and water, are usually available locally, thus saving material and transport costs. Looking even further into the future, the environmental aspects could contribute to the success of this concept: the material used could be a mixture of demolition wastes. The waste from demolished buildings pollutes the environment, but this method could return it into the materials cycle.

FutureLAB of Architecture, an interdisciplinary research institute supported by the multi-technology company 3M has completed the first house built with a 3D printer. It may not be a house with conventional dimensions, as it offers a living space reduced to the bare minimum floor area and has a height of around 3 metres, but the building is a well-designed and complete unit: kitchen, bathroom, bed, shelving – everything is constructed in a single printing process, layer-by-layer. Even the building services equipment is integrated into walls, floors and ceilings, including electrical cabling and water pipes, and printed in the same operation.

### 3D printing in wood

The 3D printing service provider i.materialise offers the first 3D printing service for objects manufactured from a wood-based material. The company uses selective laser sintering technology (SLS) to manufacture 3D objects out of a very fine, granular powder based on wood chips. This gives the surface a sandy, granular look which is slightly porous. This combination of new wood-based materials

and SLS technology can realise even complex components with interdependent and moving parts that cannot be made of wood-based materials using conventional manufacturing processes. (<https://i.materialise.com/3d-printing-materials/wood>).



i.materialise: 3D printing in wood

A closer look at the development of 3D printing reveals that quality and efficiency are improving at a rapid pace. Costs will fall as demand increases and new materials for a wide range of applications will continue to be found. This could yield one of the greatest potentials for this technology: if we can mix and prepare materials like those used by i.materialise, then whole buildings could be printed out of naturally renewable materials, which would also present new challenges to the timber construction industry.

Merging this technology with others offers huge opportunities. For example, the technology for the precise, highly automated prefabrication of timber construction elements appears open to adapting 3D printing to integrate building services elements into products, in a similar way to that mentioned in the 3M project. The development of the technology is unstoppable and will certainly find niches where its advantages can be exploited.

## The innovation & cooperation factor

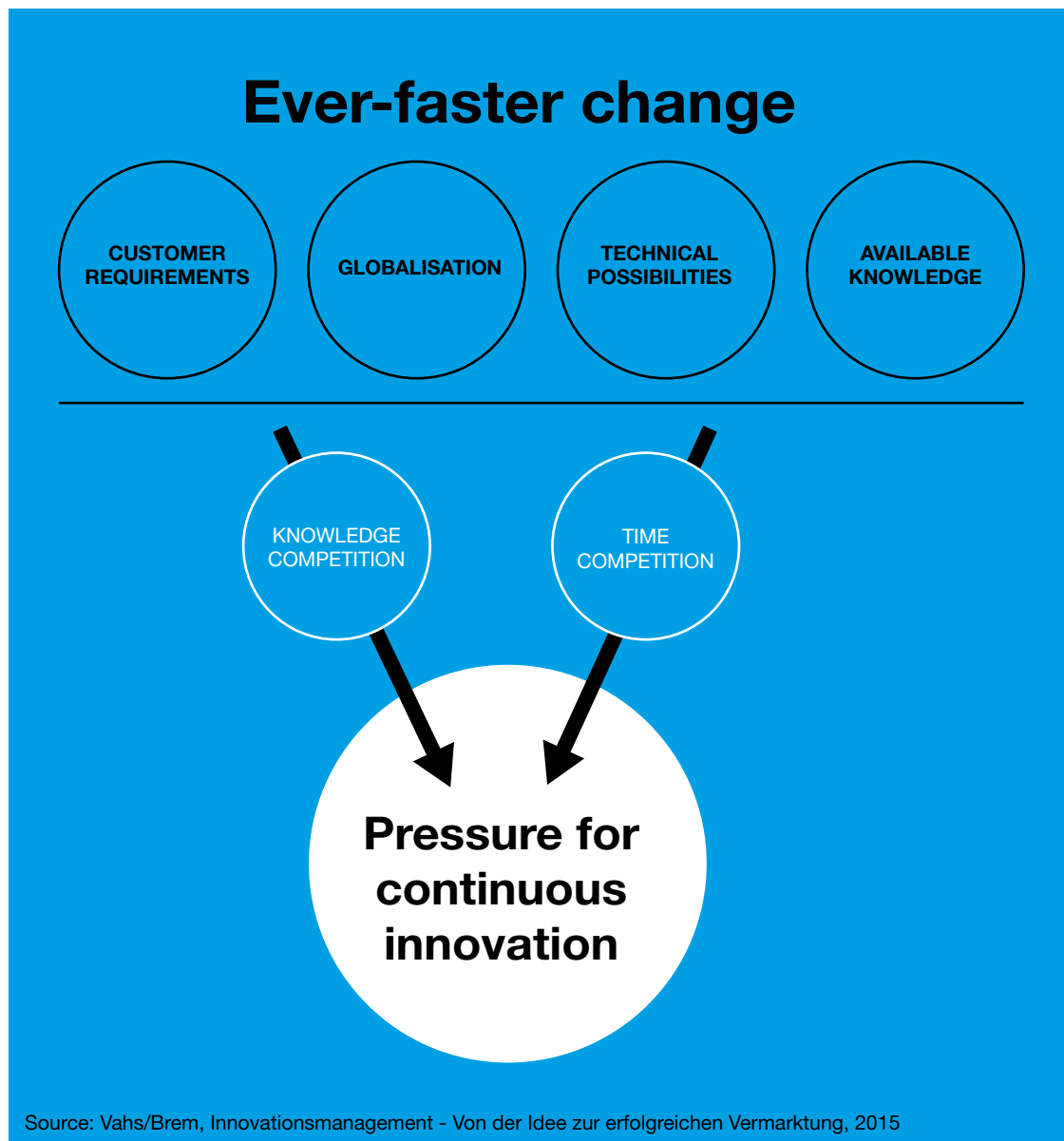

It is currently evident in the international construction industry that, especially in the new-build sector, exciting developments have taken place and that wood has taken on the role of an indispensable material in our society. Construction has reinvented itself because of the high value attached to ecological principles and the global consciousness of how we should take care of our resources. Research and development has delivered an important contribution with respect to specifications

and practical aspects of building in wood. Industrial fabrication provides a lot of scope for the form and architecture of future buildings. One of the oldest and most trusted materials is therefore making an essential contribution to resource-conscious building methods and be recognised as a hallmark of forward-looking construction. Building on this knowledge of market requirements, together with current and future technological developments, these signals must be transformed into economic

success and new products, ideas and processes brought to market. Here, it should be noted that economic development and all its factors are subject to rapid change. The speed with which developments are taking place from a technological perspective, the accumulation of available knowledge and the demands and wishes of customers are increasing rapidly. Globalisation also contributes to stronger competition in all industries, while the community of idea and innovation generators is becoming larger and more active. It is no longer enough to bring a single idea to market and expect to derive economic benefits from it over a long period. Increasing competition for knowledge and time makes it imperative to become more closely involved with innovation in general and continuously establish innovations on the market.



#### **The definition of innovation**

Innovation is the economically successful translation of an idea into a new product, service, process, marketing concept, application or business model that adds significant value to your company and its customers.

**Allied Consultants Europe, 2005**

---

Innovations can be categorised into different types based on their many and varied features. There are four principal criteria for differentiating between innovations: subject area, trigger, degree of novelty and scope of change.

### **Innovation requires a strategy**

Dealing professionally with the issue of innovation and integrating innovation management into the company can provide an indispensable contribution to preparing the way adequately for future changes and being able to react to the future needs of customers. It is therefore all the more important to establish innovation as a permanent feature of companies and to incorporate it as a crucial part of the further development of corporate strategy. As a

first step, the focus can be placed on the collective preparation of an innovation strategy with the aim of creating a basis for an innovative spirit within the company. The readiness to communicate and establish a clear position for innovation in the company are important characteristics for this to succeed.

Behind the innovation strategy runs a continuous development process that is in harmony with other sub-strategies and highlights the creation of something “new” in accordance with clearly defined aims and framework conditions for the field of business. Because anything “new” is burdened with a high uncertainty factor, it is very often necessary to make assumptions concerning its technological feasibility, market development and the continually changing behaviour of customers. Thus an innovation strategy is faced with special challenges and should therefore be viewed as a long-term learning process within a company, the success of which will attract interest through a series of realised ideas. Finally, it is a matter of turning the innovation strategy into a meaningful competitive advantage, bearing in mind that it concentrates on a single area of the value-added process and defines an early increase in value within this area, thereby differing from the corporate strategy.

### **The future of innovation: everyone develops together**

Considering all the types of innovation and possible strategies for how innovations may be positioned on the market, it can prove important in attaining this goal for innovation to become a constituent part of the culture of an organisation. The open innovation approach is without doubt one of the most promising tools for use in the development of new ideas. It is basically a simple way of working with other organisations or companies on the development of ideas and allowing them to take part in the process. For example, it would allow customers, suppliers, research institutions and universities to work together on generating innovations. Core competencies can be combined with external ways of



thinking, which helps companies keep their strategies on the right course. According to the European Union's "Innovation Futures" project, the trend is moving in the direction of allowing companies to create innovations openly, easily and jointly with others. Creative development processes will be outsourced, the Internet searched automatically for ideas and our society will become an open source society.

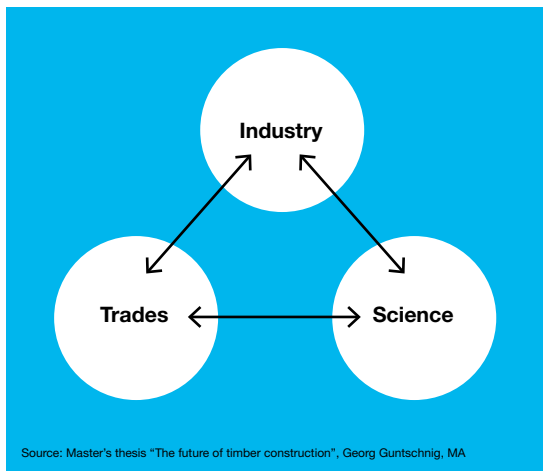

Cooperation and sharing the common path will lead to the exploitation of the full potential of an innovation and help sustain timber construction in its development vis-à-vis other forms of construction.

“ The development of timber construction is progressing well at the moment. Its future development will depend upon how successful we are in networking science, industry and the trade. **Georg Guntschnig, 2015**

## Open innovation – a cultural challenge

10 essential elements for the success of open innovation

1. Choose people within the organisation who are capable of building and managing relationships with customers and partners.
2. A readiness to accept that ideas could come from outside the organisation and that these ideas may be integrated into the organisation's business model.
3. An understanding that innovations can also fail and that the causes and errors are a learning experience and a chance for something new to emerge.
4. A readiness to support employees in the acquisition of knowledge and understanding of how ideas or technologies can be transformed into a profitable business model.
5. An acceptance that innovation does not always have to be developed inside a company's own organisation but may be bought from an external source.
6. A readiness to endeavour to achieve a balance between internal and external research and development.
7. Establishment of a readiness to accept a certain amount of risk and be generally non-risk averse.
8. An acceptance that open innovation makes a contribution to increasing intellectual property and to achieving the commercial goals of the company.
9. An understanding that open innovation is open communication and requires a certain amount of trust in employees.
10. The patience not to always be the first on the market with an idea but to develop better business models than the competition.

# Conclusion

## **New technologies as the driving force of industry dynamics in timber construction**

The building industry, in particular that part of the industry which focuses on the use of wood, is characterised by a traditional mindset that has been shaped over many generations. This provides a good foundation and ensures the stability and security of the industry. It cannot in any way be compared with the dynamism of the automobile or IT industries, but has been able to display striking progress in the last decade. This progress has not only been the result of short-lived trends or changes in the needs of society, but also through technological developments and new possibilities surrounding the use of wood as a construction material. In addition to the current digital changes taking place in the industry, the new material cross laminated timber (CLT) provides a tangible example of a development that has opened new, previously unattainable dimensions for the wider, and also “higher” use of timber in buildings. This easily formed building material has also played an important part in ensuring that wood will see increasing use as a structural material in future. It is clear that traditional timber construction is presently enjoying a revival, not just within the industry but also among architects, structural engineers and investors. The strengths and the use of wood in this refined form, together with the fulfilment of economic and ecological requirements relating to future buildings, indicate that there is still enormous potential for the material and provide hope for the future.

## **New media promotes attractiveness and networks the generations**

Our readiness to make a contribution to climate protection and the end customer’s rising acceptance of timber as a building material are now widely acknowledged as fact throughout society. The possible use of wood in buildings would benefit from still greater and more targeted communication as well as more effort on a wide range of levels, both regionally and nationally. Global showcase projects built of wood, completed or currently under way, are positive signs of a real awareness of the traditional building material in our society. The present opportunities offered by digitalisation for propagating information all over the world in next to no time are not yet fully exploited and could still be put to greater use. This would trigger a number of different effects: on the one hand, the attractiveness of the material would become more widely known and its strengths and possibilities positioned more purposefully in order to achieve this goal. On the other hand, and much more important for the development of timber construction, it would deliver an early message to the members of every generation who will influence our future choices and actions in the commercial world. The combination of years of experience with innovative, modern ways of thinking and new technologies would allow many companies to bring themselves up to date, adopt state-of-the-art technologies and prepare for future challenges.

## Stagnation is a breeding ground for substitute technologies

If CLT is viewed in terms of the phases of its product lifecycle, then it can be assumed with certainty that the material is at the beginning of an era of growth. This assumption is underlined by the prediction of many different experts who estimate that the worldwide market volume of CLT will reach 2.5 to 3.0 million cubic metres within a decade. An ambitious target, but one which can certainly be considered realistic if the development of markets beyond Europe is taken into account. The key to success, however, is not to focus only on the product and its generic market expansion.

On the contrary, the producing companies, in particular in Central Europe, will need to develop integrated solutions for the timber buildings of the future, in which CLT must play a significant part. To fail to realise this forward-looking development would provide an ideal breeding ground for other, substitute technologies. It would, for instance, be perfectly conceivable for a company from a completely different industry to move into the gap, as the electrical vehicle manufacturer Tesla did in the automotive industry, and – in the case of timber buildings – combine smart home technologies from the digital revolution with sustainable construction technologies and bring the results to market. The focus is no longer on a single, apparently unimpeachable technology, but on the merging of technologies into a new, integrated whole that accords with the spirit of the age, initiates enthusiasm with investors and finally leads to the desire to purchase.

## Cooperation creates sustainable advantages

Our ability to harness present and future technological developments and bring new products and services to the market will depend very much on our preparedness to integrate previous unknowns into our companies. The challenge is in the hands of timber construction organisations that recognise the signs of the times and introduce the necessary measures to meet the above objectives. To achieve this, it will often be necessary to strike off in new directions, encourage innovations and seek cooperation with others. Researchers, the industry and the trade have never been so united in a common will to further develop wood as a building material. A change in direction towards the open innovation approach could prove to be the key to success and give the desired boost to the renewable building material, wood.

Georg Guntschnig, MA  
Wolfsberg, 20.02.2016



# Timber construction today

To get a feel for the industry, the Zukunftsinstitut asked a number of different experts about "Timber construction today and in the future". The result paints a multifaceted picture.

## The experts who took part in this online survey:

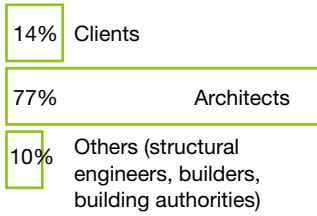

**93%**

believe that wood will advance to become a competitive building product

**77%**

are of the opinion that lawmakers should prescribe the use of environmentally friendly products

## Ecology, short construction time, comfort:

are the most important advantages of wood

## Ecological and comfortable: the advantages of wood

Which advantages of wood do architects and clients rate particularly highly (Agreement in %)

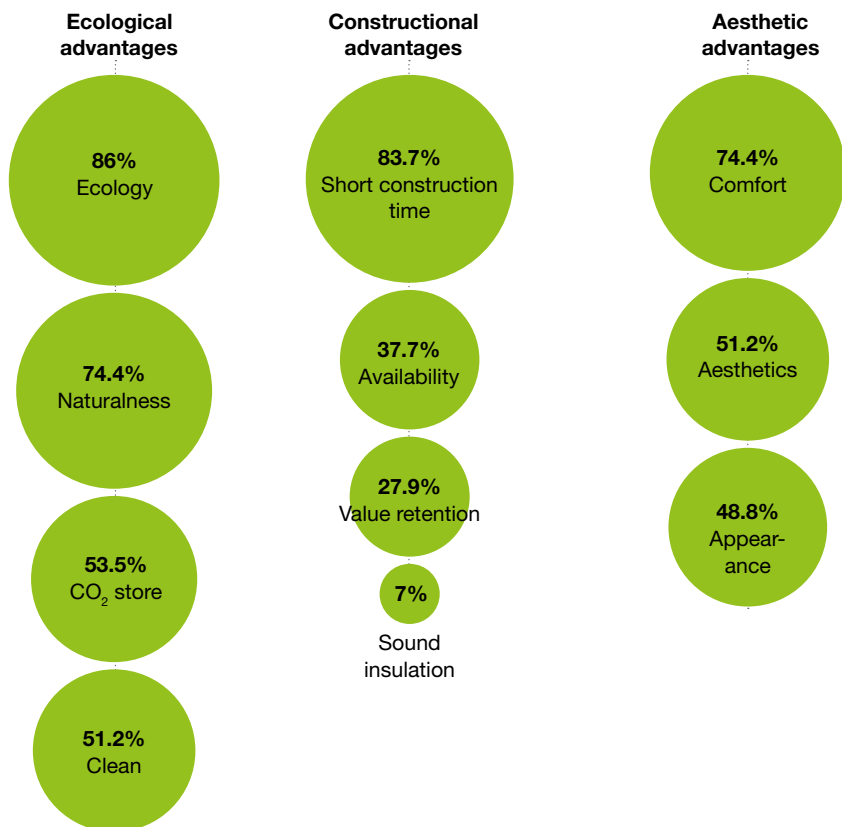

## Steel is the material most compatible with wood

Which construction material is the ideal partner for cross laminated timber? (Agreement in %)

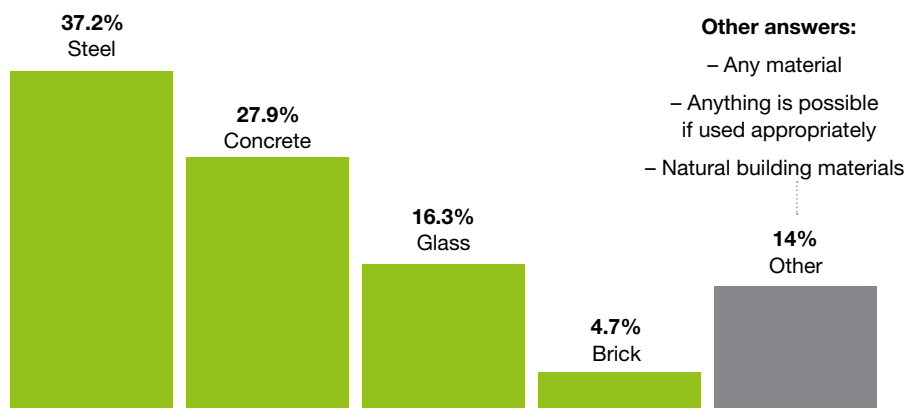

### Environmentally friendly products should be prescribed by law

Views of architects and clients on various questions about the timber construction industry (Agreement in %)

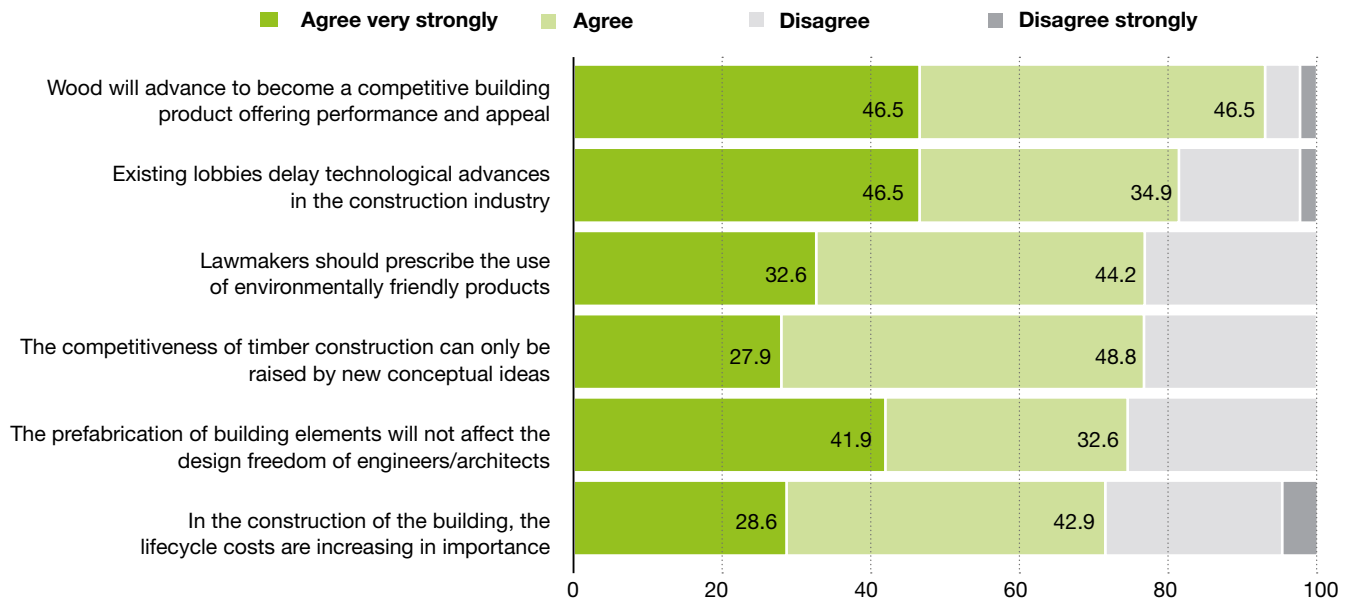

### Know-how is the biggest deficit

What are the most important reasons why wood is not more frequently used as a structural element in buildings?

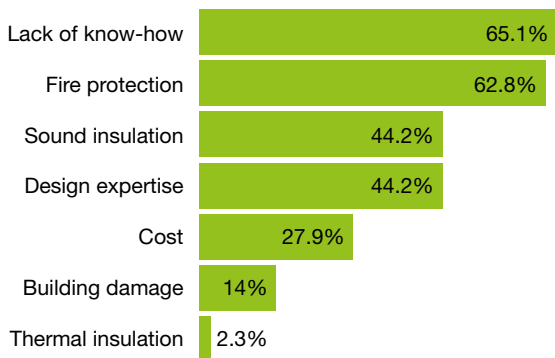

Is the industry doing enough educational work to highlight what can be achieved with timber construction?

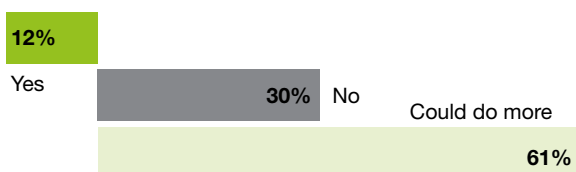

### Fire protection remains the greatest challenge

In your opinion, what are the greatest challenges in constructing multi-storey residential buildings in wood

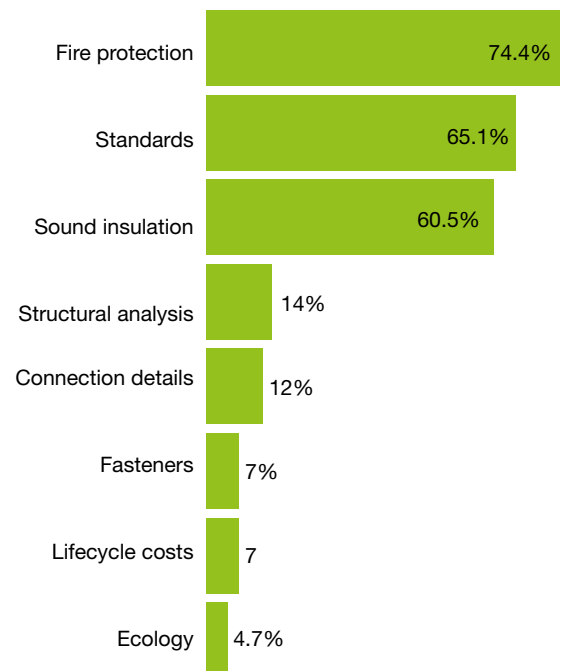

# Timber construction tomorrow

The requirements for **energy efficiency (43%)** and **flexibility (28%)** will have most influence on buildings in future

**61%**

believe that the majority of skilled workers will not be present on site

**The lack of skilled workers on site is an indicator of the investment made to achieve a higher degree of prefabrication**

**65%**

see carpentry firms as partners of architects, clients and general contractors - only 35% as installers

**Land (81%) and technical building services (74%)** will be by far the greatest cost drivers for buildings in the future

## Energy efficiency will be the critical factor

What social aspects will influence buildings in the future?

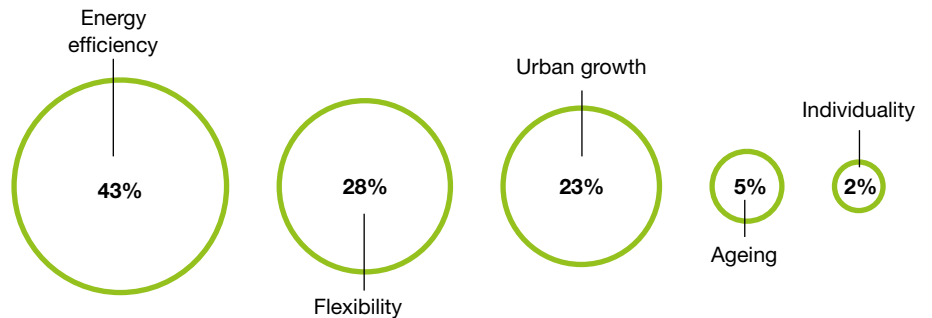

## Land will constitute the greatest cost

In your opinion, what factors will be the greatest cost drivers for buildings in the future (agreement in %)

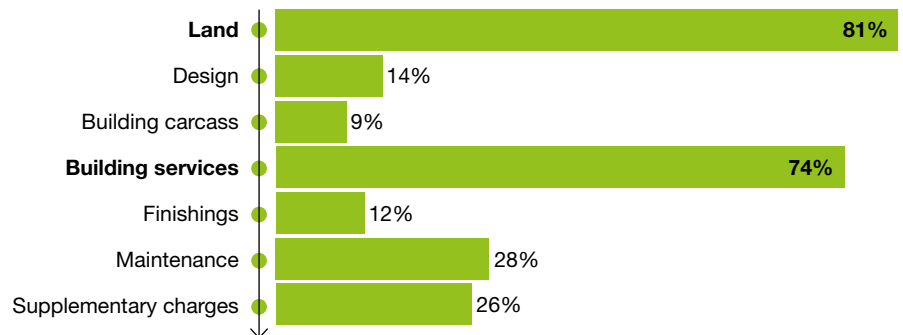

## Suitable expertise is in short supply on site

At what point in the value-added chain will there be the fewest skilled workers in future? (Agreement in %)

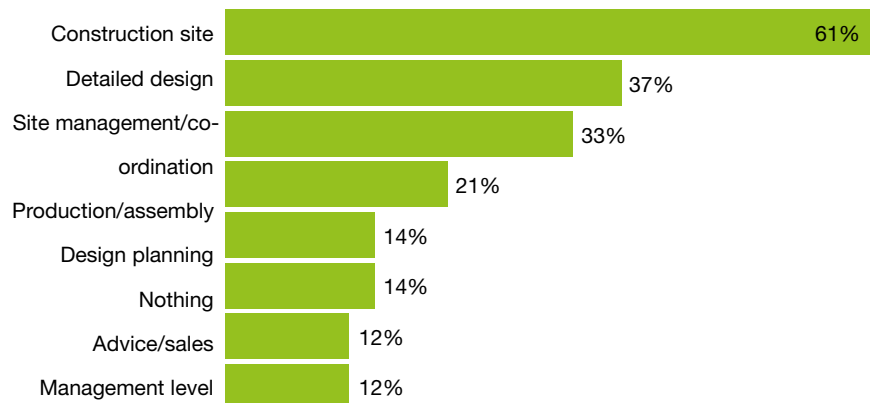

### Further development and extensions instead of new builds

Views on various aspects of timber construction today (agreement in %)

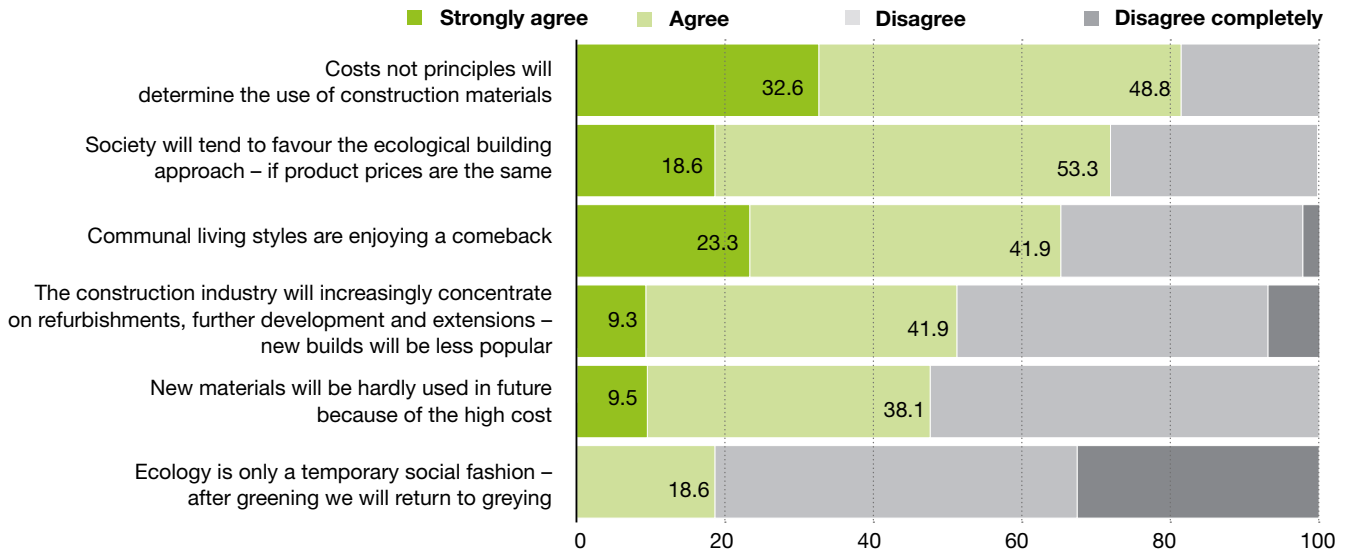

### Carpentry firms remain relevant

How do you see the future role of carpentry firms in the use of CLT?

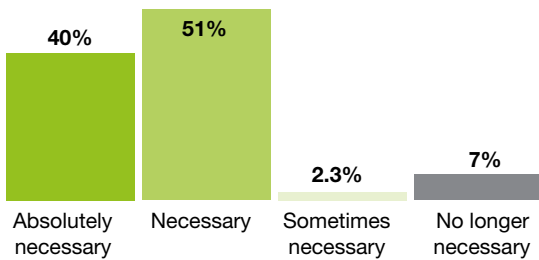

### Prefabrication still capable of development

In your view, where is the greatest technological development potential for CLT in future?

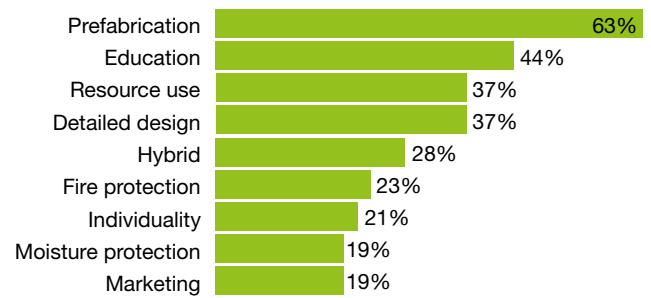

### Carpentry firms: more than installers

How do you see the future role of the traditional carpentry firm in multi-storey timber housing construction?

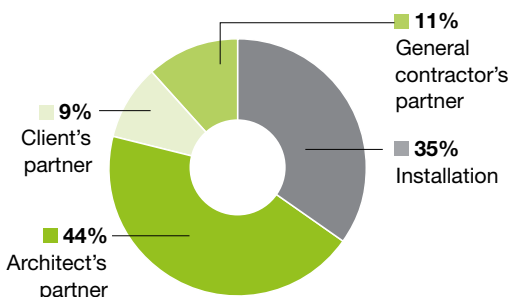

### Challenging, but necessary

Digitalisation is penetrating the construction industry and demands a rethink of the complete construction process. What is your view of this?

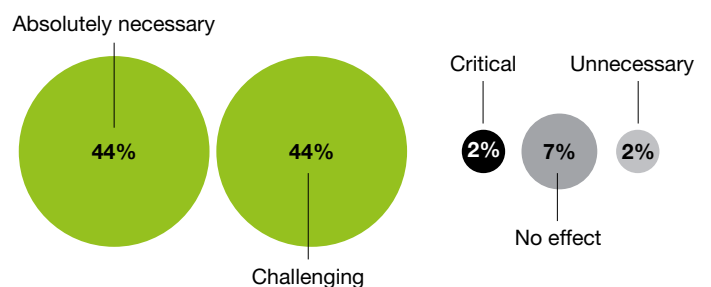

# **Trends that will do the most damage to the timber industry**

Top 3 according to the survey participants

- Lobbying by the masonry and concrete construction industry**
- Advantages over timber construction**
- Too many standards and regulations**



# Trends that will drive the timber industry most

– Ecology

– Short construction times

– Flexibility

- Allied Consultants Europe (Ed.) (2012):** A comprehensive guide to “Efficient Open Innovation”, Benefits and challenges – A European perspective. In: <http://www.ace-openinnovation.com/media/publisher/report2012/files/assets/basic-html/page3.html>
- Aravena, Alejandro (2014):** TED Talk: My Architectural Philosophy? Bring the Community Into the Process. In: <http://www.archdaily.com/564819/ted-talk-my-architectural-philosophy-bring-the-community-into-the-process-alejandro-aravena>
- Arte (2015):** Häuser aus dem 3D-Drucker. In: <http://sites.arte.tv/futuremag/de/hauser-aus-dem-3d-drucker-futuremag> [Stand 11.03.2016]
- Barr, Caelainn, Malik, Shiv (2016):** Millennials: the trials of Generation Y. In: The Guardian, 07.03.2016, <https://www.theguardian.com/world/2016/mar/07/revealed-30-year-economic-betrayal-dragging-down-generation-y-income>
- Binder, Gerald; Hecke, Meral Akin; Röhler David (Eds.) (2015):** Das neue Arbeiten im Netz, Augmented Reality zeigt mehr, als sichtbar ist. In: <https://www.werdedigital.at/leitfaden/leitfaden-werdedigital-at/>
- Borrmann, A., König, M., Koch, C., Beetz, J. (Eds.) (2015):** Building Information Modelling, Technologische Grundlagen und industrielle Praxis, Springer Fachmedien, Wiesbaden
- Bundesministerium für Verkehr, Innovation und Technologie (Ed.) (2012):** Innovationsland Österreich, Ein Blick auf Österreichs Forschung und Innovation, without publisher, Vienna
- Burmeister, Klaus; Glockner, Holger (2009):** Handbuch der Zukunft 2010, Trends, Herausforderungen, Chancen, 1st edition, FOCUS Magazin Verlag GmbH, Munich
- Deezeen Magazin (2015):** Architects embrace „the beginning of the timber age.“ In: <http://www.dezeen.com/2015/11/09/cross-laminated-timber-construction-architecture-timber-age/> [Stand 15.05.2016]
- Fachverband der Holzindustrie Österreich (Ed.) (2013):** Die österreichische Holzindustrie – Branchenbericht 2012/2013, ohne Verlagsangaben, Vienna
- Gatterer, Harry; Baumgartner, Michael; Seidel, Adeline; Varga, Christiane (2013):** Zukunft des Wohnens – Die zentralen Trends bis 2025, 1st edition, Zukunftsinstitut, Frankfurt am Main
- Gatterer, Harry (2016):** Pro Aging - Die Alten machen uns jung. Zukunftsinstitut, Vienna/FFM
- Gassmann, Oliver; Sutter, Philipp (2011):** Praxiswissen Innovationsmanagement, Von der Idee zum Markterfolg, 2nd edition, Carl Hanser Verlag GmbH & Co. KG, Munich
- Gassmann, Oliver (2013):** Keine halben Sachen. In: Harvard Business Manager, Vol. 2/2013, P. 32-33
- Green, Michael (2013):** Why we should build wooden skyscrapers. In: [https://www.ted.com/talks/michael\\_green\\_why\\_we\\_should\\_build\\_wooden\\_skyscrapers/transcript](https://www.ted.com/talks/michael_green_why_we_should_build_wooden_skyscrapers/transcript)
- Grohe (Ed.) (2014):** Lässt sich mit Slow Architecture ein neuer Umgang mit Stadt und Landschaft erreichen? In: [http://www.grohe.com/application/filebrowser/library/de/architektur/Slow-Architecture\\_25-09-2014\\_Duesseldorf.pdf](http://www.grohe.com/application/filebrowser/library/de/architektur/Slow-Architecture_25-09-2014_Duesseldorf.pdf)
- Gronalt, M.; Teischinger A.; Holztechnologie (Eds.) (2015):** Industrie 4.0 – die Produktion in der Holzwirtschaft von morgen? In: Holztechnologie 56, 3rd edition, Dresden
- Guntschnig, Georg (2011):** Massivholzelemente – intelligenter, vielseitiger, ökologischer. Without publisher, Graz
- Guntschnig, Georg (2012):** Produktentwicklung und Produktpositionierung mit Design - Innovationskriterium für Unternehmen in der gegenwärtigen und zukünftigen Markt- bzw. Wettbewerbssituation, without publisher, Graz
- Guntschnig, Georg (2013):** Foresight im Holzbau – Strategische Zukunftsbetrachtung der Entwicklung im Holzbau zur Ableitung von Ideen für den zukünftigen Einsatz der Brettsperrholztechnologie, without publisher, Graz
- Guttman, Eva (2008):** Brettsperrholz – Produktportrait, in: Zuschnitt 2008, Vol. 31, P. 13
- Holzforschung Austria (Ed.):** Einteilung der Holzbauweisen im Wohnbau. In: <http://www.infoholz.at/katalog/eintrag/holzhausbauweisen-definition.htm>
- Horx, Matthias (Ed.) (2015):** Zukunftsreport 2016. Zukunftsinstitut, Vienna/FFM
- IBO – Österreichisches Institut für Baubiologie und Bauökologie (Ed.):** Baubook Ökoindex. In: <http://www.baubook.at/oekoindex/> [date 15.03.2016]
- Kaufmann, Hermann; Nerdinger, Winfried (Ed.) (2013):** Bauen mit Holz, Wege in die Zukunft, Prestel Verlag, Munich

- Linde, Hansjürgen; Herr, Gunther; (2009):** WOIS – Weltwettbewerb der Innovationsstrategien, without publisher, Coburg
- Lindegaard, Stefan; (2010):** The Open Innovation Revolution: Essentials, Roadblocks and Leadership Skills, Wiley
- Materialise nv (2016):** 3d Printing Materials in Wood. In: <https://i.materialise.com/3d-printing-materials/wood> [Stand 01.03.2016]
- Meissner, Jens (2011):** Einführung in das systematische Innovationsmanagement, 1st edition, Carl-Auer Verlag, Heidelberg
- Mintzberg, Henry (1987):** The Strategy Concept 1, Five Ps For Strategy. In: California Management Review, Vol. 30, P. 11-24
- Mintzberg, Henry; Ahlstrand, Bruce; Lampel, Joseph (1999):** Strategy Safari, Eine Reise durch die Wildnis des strategischen Managements, Wirtschaftsverlag Carl Ueberreuter, Vienna/Frankfurt
- Morozov, Evgeny (2015):** Why growing old the Silicon Valley way is a prescription for loneliness. In: The Guardian, 24.10.2015, <https://www.theguardian.com/commentisfree/2015/oct/24/growing-old-silicon-valley-prescription-for-misery>
- Pauli, Gunter (2010):** The Blue Economy. Paradigm Publishers, Taos, New Mexico, USA.
- Plackner, Hannes (2013a):** Ein Produkt mit Reifeprüfung. In: Holzkurier
- Porter, Michael (1996):** What is Strategy? In: Harvard Business Review, edition 96608, P. 61-78
- proHolz Austria (2011a):** Holzhäuser. Wohnen mit Holz – zeitlos schön. In: <http://www.proholz.at/holzistgenial/2007/holz-haus-1.htm>
- PwC (2015):** Industry 4.0 Self Assessment. In: <https://i40-self-assessment.pwc.de/i40/landing/> [date 10.03.2016]
- Rauch, Christian (2016):** Slow Business, Wie aus Achtsamkeit eine neue Wertschöpfung entsteht. Zukunftsinstitut, Vienna/FFM
- Schickhofer, Gerhard; Bogensperger, Thomas; Moosbrugger, Thomas (2010):** BSPhandbuch. Holz-Massivbauweise in Brettsperrholz, Nachweise auf Basis des neuen europäischen Normenkonzepts, 2nd edition, Verlag der Technischen Universität Graz, Graz
- Schumpeter, Joseph (1964):** Theorie der wirtschaftlichen Entwicklung, 6. Auflage, Duncker & Humboldt, Berlin
- Schober, K. P. et al. (2002):** Mehrgeschoßiger Holzbau in Österreich - Holzskelett- und Holzmassivbauweise. proHolz Austria, Vienna.
- Stora Enso (Ed.) (2009):** CLT Wand- und Deckenelemente. In: <http://www.massivholzsystem.at/cms/index.php/2012-02-20-13-10-10/allgemeines-2> [Stand 10.11.2013]
- Stora Enso (Ed.) (2013b):** Technische Daten zu Brettsperrholz. In: <http://www.clt.info/media-downloads/broschueren/broschueren/> [date 15.06.2016]
- Studiengemeinschaft Holzleimbau (Ed.) (2010):** Planen und Bauen mit Brettsperrholz - Bauprodukt Brettsperrholz. In: Bauen mit Brettsperrholz 2010, 2nd edition, P. 6-34
- Studiengemeinschaft Holzleimbau (Ed.):** Brettsperrholz – Holzarten. In: [http://www.brettsperrholz.org/brettsperrholz-bsp-x-lam/eigenschaften-allgemein/holzarten/mn\\_45183](http://www.brettsperrholz.org/brettsperrholz-bsp-x-lam/eigenschaften-allgemein/holzarten/mn_45183) [Stand 10.11.2013]
- Teibinger, Martin; Matzinger, Irmgard; Holzforschung Austria (Ed.) (2013):** Bauen mit Brettsperrholz im Geschossbau, Fokus Bauphysik, without publisher, Vienna
- Thoma, Erwin (2016):** Die geheime Sprache der Bäume: Und wie die Wissenschaft sie entschlüsselt. 1st edition, Benevento, Salzburg.
- Vahs, Dietmar; Brem, Alexander (2013):** Innovationsmanagement - Von der Idee zur erfolgreichen Vermarktung, 4th edition, Schäffer-Poeschl Verlag, Stuttgart
- Wilson, Edward (1984):** Biophilia. Harvard University Press, Harvard, USA.
- Zukunftsinstitut GmbH (Ed.) (2015):** Immobilien Report 2016. Communicating Architecture. Zukunftsinstitut, Vienna/FFM

