

Tambrite™ PE Green New

Fully coated folding boxboard

Tambrite PE Green is a renewable polyethylene-coated GC2 board. The board has chemical pulp layers on both sides and pressure groundwood in the middle layer. The top is white and the reverse is cream, coated with transparent LDPE Green. Tambrite PE Green is also available hard-sized (HS).

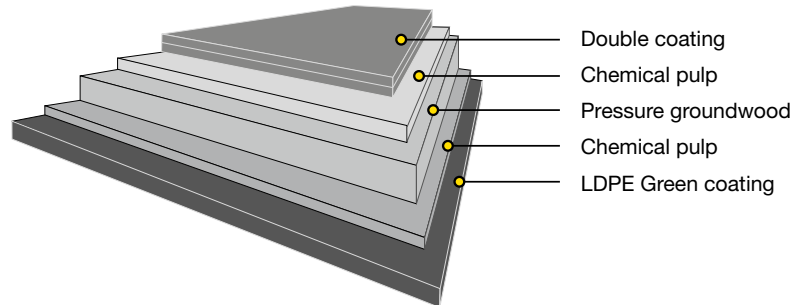

Issued: 11.2023
Cancels: -

Technical specification

Specification article		TB375	TB400	TB420	TB440	TB460	TB480	TB500	TB540	TB600	TB650	
Property/Unit	Tolerance	200+15	210+15	220+15	230+15	240+15	250+15	260+15	275+15	300+15	325+15	Standard
Polymer coated board:												
Grammage, g/m ²		215	225	235	245	255	265	275	290	315	340	ISO 536
Polymer reverse, g/m ²		15	15	15	15	15	15	15	15	15	15	Mill method
Thickness, µm		390	415	435	455	475	495	515	555	615	665	ISO 534
Baseboard:												
Thickness, µm	±4% or max. ±20µm	375	400	420	440	460	480	500	540	600	650	ISO 534
Grammage, g/m ²	±4%	200	210	220	230	240	250	260	275	300	325	ISO 536
Bending resistance L&W 15° MD, mN	-15%	221	257	296	335	375	424	476	571	735	905	ISO 2493-1
Bending resistance L&W 15° CD, mN	-15%	122	141	161	182	203	228	255	302	383	464	
Bending moment Taber 15° MD, mNm	-15%	10.7	12.4	14.3	16.2	18.1	20.5	23.0	27.6	35.5	43.7	
Bending moment Taber 15° CD, mNm	-15%	5.9	6.8	7.8	8.8	9.8	11.0	12.3	14.6	18.5	22.4	
Bending stiffness DIN 5° MD, mNm	-15%	21.3	24.7	28.5	32.2	36.1	40.9	45.9	55.1	70.8	87.2	
Bending stiffness DIN 5° CD, mNm	-15%	11.8	13.6	15.6	17.6	19.6	21.9	24.5	29.1	36.9	44.7	
Moisture, %	±1	8.0	8.0	8.0	8.0	8.0	8.0	8.0	8.5	8.5	9.0	ISO 287
ISO Brightness C/2°, %, Top	min. 84	86	86	86	86	86	86	86	86	86	86	ISO 2470-1
Surface Smoothness, PPS 10, µm, Top	max. 1.5	1.2	1.2	1.2	1.2	1.2	1.2	1.2	1.2	1.2	1.2	ISO 8791-4
Scott Bond, J/m ²	min. 100	130	130	130	130	130	130	130	130	130	130	TAPPI 569
Robinson chocolate test		max. 0.5 for one year storage in reels/pallet										EN 1230-2



Tambrite™ PE Green New

Fully coated folding boxboard

Certificates

- Quality management ISO 9001
- Environmental management ISO 14001
- Product safety FSC 22000
- Occupational health and safety ISO 45001
- Energy management ISO 50001



FSC and PEFC certified board available upon request.

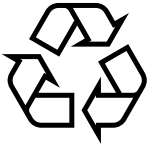

Paperboard can be recycled

Key characteristics and main enduses

Tambrite PE Green is a fully sustainable material that provides the same high level of protection and convertibility, but in a sustainable form. PE Green is a transparent coating made of renewable raw material. Tambrite PE Green offers excellent value, runnability and performance in applications that require protection against humidity. The continuous development of Tambrite has resulted in excellent stiffness and bulk attributes, and the board has a good visual appearance and performs well in printing and converting processes, including digital printing, laser and inkjet coding. Tambrite PE Green helps optimize package performance, ensures high visual quality and saves materials, thus helping to reduce food waste. In food packaging, Tambrite is the best choice when the package's tactile strength is to communicate quality.

Printing and finishing techniques

The product can be used with different printing techniques such as offset, flexo, rotogravure and digital printing. In digital printing, the product is suitable for several different sheet- or web-fed presses. Inkjet, dry or liquid toner technology can be used, although in some cases, pretreatment of the substrate might be required. The latest certification status can be verified on the press manufacturer's website or with local Stora Enso representatives. It is important to check the limitations of the equipment, particularly because of the exceptional difference in the thickness and stiffness of board compared with paper in the same grammages. When running thicker substrates, the press manufacturer's recommendations should be referred to for optimal grain direction. Essentially all of the same finishing processes apply to both digitally printed and offset printed work. Since a wide variety of digital printing equipment is available in the market, it is important that a new commercial print job is always preceded by a trial run, including all required printing and converting process phases. The product works very well with different finishing techniques, such as embossing, hot foil stamping and others. It is suitable for laser coding and ink jet marking. Certificates according to PTS-DF 105/2019 and PTS-DF 103/2022 are available upon request.

Storage recommendations

For optimal printing results, the moisture proof wrapping should not be removed until the board has reached the temperature of the press room.

Pallet/Reel Weight (kg)	Difference in temperature between board and press room (press room temp. approx. 20°C)		
	10°C	20°C	30°C
400 kg	2 days	2 days	3 days
800 kg	2 days	3 days	4 days
1200 kg	2 days	4 days	5 days

The product properties, according to the specifications, are guaranteed for 12 months after the production date. In order to ensure product safety, the product must be well wrapped and stored indoors, sheltered from rain and snow. The recommended storage conditions are 50–55% relative humidity and 20–23°C.

For the Corona treatment, we recommend using the board within 12 months of the production date; after this period, the treatment level should be tested before printing or gluing.