

Two-side coated graphical board

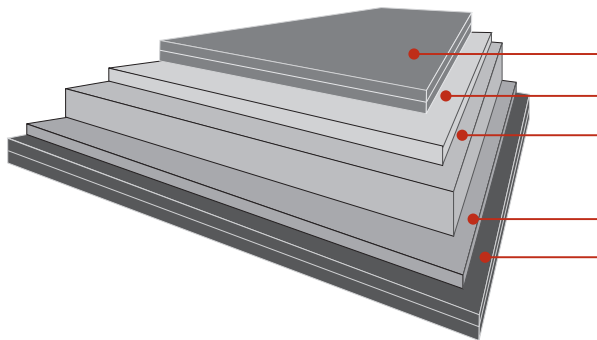

- Double coating
- Top-layer (bleached chemical pulp)
- Middle-layer
(bleached CTMP + bleached chemical pulp)
- Top-layer (bleached chemical pulp)
- Double coating



ISO 9001

Specifications for Performa 2S:

Property / Unit	Tolerance									Standards
Grammage, g/m ²	± 4 %	215	245	270	300	330	360	400		ISO 536
Thickness, µm	± 4 %	255	300	350	400	450	500	550		ISO 534
Bending moment Taber 15° MD, mNm		6.7	10.4	14.3	19.6	25.1	33.3	43.5		ISO 2493
Bending moment Taber 15° CD, mNm		3.3	5.1	7.1	9.3	11.8	15.2	19.3		
Bending resistance L&W 15° MD, mN		139	215	295	405	520	690	900		
Bending resistance L&W 15° CD, mN		68	105	147	192	245	315	400		
Moisture, %		6.5	6.5	6.5	6.5	6.5	6.5	6.5		ISO 287
ISO Brightness C/2°, %		93	93	93	93	93	93	93		ISO 2470
Brightness D65/10°		100	100	100	100	100	100	100		SCAN-P3
Surface Smoothness, PPS 10, µm		1.2	1.2	1.2	1.2	1.2	1.2	1.2		ISO 8791-4
Surface Smoothness, Bendtsen, ml/min		30	30	30	40	40	40	40		ISO 8791-2
Scott Bond, J/m ²		220	220	220	220	220	220	220		TAPPI 569 pm-00

All properties according to Imatra Mill measurements.

Test climate 23°C/50% RH (According to ISO 187). In order to verify, reel/pallet average shall be based on 5 single measurements randomly sampled within the reel/pallet. These averages will be for at least 19 of 20 reels/pallets within the specification limits.

Imatra Mills have certified FSC and PEFC Chain-of-Custody (CoC) systems as well as certified hygiene management system.

FSC: Certificate registration code SA-COC-001548 and SA-CW-001548
PEFC: Certificate registration no. 46786-2009-AE-FIN-FINAS

For more information contact your local sales office.

