



ETA-Danmark A/S
Göteborg Plads 1
DK-2150 Nordhavn
Tel. +45 72 24 59 00
Fax +45 72 24 59 04
Internet www.etadanmark.dk

Authorised and notified according
to Article 29 of the Regulation (EU)
No 305/2011 of the European
Parliament and of the Council of 9
March 2011

MEMBER OF EOTA



European Technical Assessment ETA-20/0893 of 2026/06/16

I General Part

Technical Assessment Body issuing the ETA and designated according to Article 29 of the Regulation (EU) No 305/2011: ETA-Danmark A/S

Trade name of the construction product:

Sylva™ CLT Rib by Stora Enso

Product family to which the above construction product belongs:

Prefabricated wood-based loadbearing stressed skin panels

Manufacturer:

Stora Enso Wood Products GmbH
Bahnhofstrasse 31
A-3370 Ybbs an der Donau
Internet www.storaenso.com

Manufacturing plant:

Stora Enso Wood Products

This European Technical Assessment contains:

27 pages including 4 annexes which form an integral part of the document

This European Technical Assessment is issued in accordance with Article 95(4) of Regulation (EU) 2024/3110, on the basis of:

EAD 140022-00-0304 for Pre-fabricated wood-based loadbearing stressed Skin Panels

This version replaces:

The ETA with the same number issued on 2023-10-13

Translations of this European Technical Assessment in other languages shall fully correspond to the original issued document and should be identified as such.

Communication of this European Technical Assessment, including transmission by electronic means, shall be in full (excepted the confidential Annex(es) referred to above). However, partial reproduction may be made, with the written consent of the issuing Technical Assessment Body. Any partial reproduction has to be identified as such.

II SPECIFIC PART OF THE EUROPEAN TECHNICAL ASSESSMENT

1 Technical description of product and intended use

Technical description of the product

Sylva™ CLT Rib elements are composite panel elements, made of Stora Enso Cross Laminated Timber panels (ETA-14/0349) and glued laminated beams according to (EN 14080). The adhesive shall conform to type I according to EN 15425 or EN 301. Sylva™ CLT Rib contain screws to create gluing pressure or to fix secondary construction elements, but they do not have an influence on the composite effect. Glued laminated timber, CLT and LVL may be used for blockings at supports. The materials, dimensions and tolerances are given in Annex 1.

Typical length of the product is 5 m to 16,5 m. The thickness of the CLT panel is 60 mm to 200 mm. The geometry of the glulam rib is rectangular; minimum cross section dimensions are depth 100 mm and width 60 mm. All other boundary conditions on shape and size are given in Annex 1.

Manufacturing

Gluing of CLT panels to ribs are performed in accordance with the provisions of this European technical assessment and according to the ETA holder's instructions.

The segments shall be bonded together to the required width of the laminated segment timber.

2 Specification of the intended use in accordance with the applicable European Assessment Document (hereinafter EAD)

Sylva™ CLT Rib elements are intended to be used as structural or non-structural elements in buildings. The panels shall have single span supported at the ends as described in Annex 1. The panels are intended to be used subject to static or quasi-static actions only.

In seismic areas the behavior factor of Sylva™ CLT Rib used for the design is limited to non-dissipative or low-dissipative structures ($q \leq 1,5$), defined according to Eurocode 8 (EN 1998-1:2004 clauses 1.5.2 and 8.1.3 b) and applicable national rules on construction works.

With regard to moisture behavior of the product, the product shall be used in service classes 1 and 2, according to EN 1995-1-1. The product shall not be used in use class 3 (3.1 exterior, above ground, protected; occasionally wet).

The provisions made in this European Technical Assessment are based on an assumed intended working life of the wood slab elements of 50 years.

The real working life may be, in normal conditions, considerably longer without major degradation affecting the essential requirements of the works.

The indications given on the working life cannot be interpreted as a guarantee given by the producer or Assessment Body but are to be regarded only as a means for choosing the right products in relation to the expected economically reasonable working life of the works.

3 Performance of the product and references to the methods used for its assessment

Characteristic	Assessment of characteristic
3.1 Mechanical resistance and stability (BWR1)	
Mechanical resistance and stiffness	Clause 3.1.1
Dimensional stability	Clause 3.1.2
Durability	Clause 3.1.3
3.2 Safety in case of fire (BWR2)	
Reaction to fire	Clause 3.2.1
Resistance to fire	Clause 3.2.2
External fire performance	No performance assessed
3.3 Hygiene, health and the environment (BWR 3)	
Water vapor permeability and moisture resistance	No performance assessed
Watertightness	No performance assessed
Content, emission and/or release of dangerous substances	Clause 3.3.1
3.4 Safety and accessibility in use (BWR 4)	
Impact resistance	No performance assessed
3.5 Protection against noise (BWR 5)	
Airborne sound insulation	Annex 3
Impact sound insulation	Annex 3
Sound absorption	No performance assessed
3.6 Energy economy and heat retention (BWR 6)	
Thermal resistance	Clause 3.5.1
Air permeability	Clause 3.5.2

3.1 Mechanical resistance and stability

3.1.1 Mechanical resistance and stiffness as well as serviceability

Mechanical resistance and deformations for Sylva™ CLT Rib is given by one of the following methods:

- Method 3a: Reference to design documents of the customer
- Method 3b: Reference to design documents produced and held by the manufacturer according to the order for the works

The structural performance of Sylva™ CLT Rib shall be considered in accordance with the limit state design principles specified in Eurocodes. Both ultimate limit state and serviceability limit state (comprising vibrations when relevant) shall be considered. Calculation methods shall follow EN 1995-1-1. Material properties to be used in design and some equations for the design are specified in Annex 2. Structural design shall be documented.

A detailed explanation on design methods can be found in Stora Enso Sylva™ CLT Rib design manual.

3.1.2 Dimensional stability

In normal conditions, harmful deformations due to moisture changes of the Sylva™ CLT Rib elements are not expected.

Product / wood species	Swelling and shrinkage coefficient (in percent per percent change of moisture content)	
	Perpendicular to grain or to the panel surface	Parallel to grain or in the plane of the panel
GLT (spruce, pine)	0.24	0.01
CLT (spruce, pine)	0.24	0.02 – 0.04

Table 1: Recommendation for swelling/shrinkage coefficients (acc. to EN 1995-1-1, NA of Austria)

Between production and completion of the structure, Sylva™ CLT Rib should not unnecessarily be exposed to climatic conditions, more severe than those, expected in the finished structure.

3.1.3 Durability

The adhesive of type I/II can be used in service classes 1, 2 and 3 but natural durability class of CLT is 5 according to EN 350-2. Thus, Sylva™ CLT Rib can be used in service classes 1 and 2 according to EN 1995-1-1.

Durability may be reduced by attack from insects such as long horn beetle, dry wood termites and anobium in regions where these may be found.

When necessary and required by the local authorities, Sylva™ CLT Rib may be treated against biological attack according to the rules valid within the region. Any adverse effects of the treatment on other properties shall be taken into account. These kinds of treatments are not covered by this ETA.

3.2 Safety in case of fire

3.2.1 Reaction to fire

Untreated products are classified to have reaction to fire class D-s2, d0 in accordance with EN 13501-1 and Commission Delegated Regulation 2016/364.

Sylva™ CLT Rib elements treated against fire are not covered by this ETA.

3.2.2 Resistance to fire

Fire design of Sylva™ CLT Rib shall be performed according to standards EN 1995-1-2:2004/AC:2009 and EN 1995-1-1:2004. National determined parameters valid in the relevant Member State shall be used.

Charring rate for CLT shall be applied as per ETA-14/0349.

Charring rate for the glued laminated ribs shall be taken from EN1995-1-2, table 3.1.

Results of fire classification reports per EN 13501-2:2016 are enclosed in the Annex 4.

3.3 Content, emission and/or release of dangerous substances

3.3.1 Dangerous substances

Based on the assessment of the Assessment Body, Sylva™ CLT Rib do not contain harmful or dangerous substances as defined in the EU database, with exception of formaldehyde. CLT glued with polyurethane adhesive according to EN 15425 does not contain any added formaldehyde. Glued laminated timber used in ribs is either classified to be of class E1 or to have no formaldehyde at all, if glued with polyurethane adhesive according to EN 15425. The adhesive used in gluing the CLT slabs to glulam ribs contains minor amounts of formaldehyde, so the overall class of the product is E1.

In addition to the specific clauses relating to dangerous substances contained in this European Technical Assessment, there may be other requirements applicable to the products falling within its scope (e.g. transposed European legislation and national laws, regulations and administrative provisions). In order to meet the provisions of the EU Construction Products Directive, these requirements need to also be complied with, when and where they apply.

3.4 Energy economy and heat retention

3.4.1 Thermal resistance

The thermal conductivity λ for the rib material is 0.13 W/(m K) according to EN ISO 10456.

The thermal conductivity λ for CLT material is 0.12 W/(m K) according to ETA-14/0349.

The natural density variation of the materials is taken into account in this value.

3.4.2 Air permeability

A construction with Sylva™ CLT Rib, including the joints between the elements, will provide adequate airtightness in relation to the intended use, taking into account both energy economy and heat retention, risk of cold draughts and risk of condensation within the construction. The joints of the panels shall be tightened with a gasket.

4 Assessment and verification of constancy of performance (hereinafter AVCP) system applied, with reference to its legal base

4.1 AVCP system

According to the Decision 2000/447/EC of the European Commission, the system of assessment and verification of constancy of performance (see Annex V to the regulation (EU) No 305/2011) is System 1.

5 Technical details necessary for the implementation of the AVCP system, as provided for in the applicable EAD

Technical details necessary for the implementation of the AVCP system are laid down in the control plan deposited at ETA-Danmark prior to CE marking

Issued in Copenhagen on 2026-06-16 by

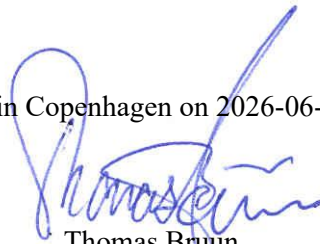

Thomas Bruun
Managing Director, ETA-Danmark

Annex 1
DESCRIPTION OF Sylva™ CLT Rib

1. Sylva™ CLT Rib sections and size

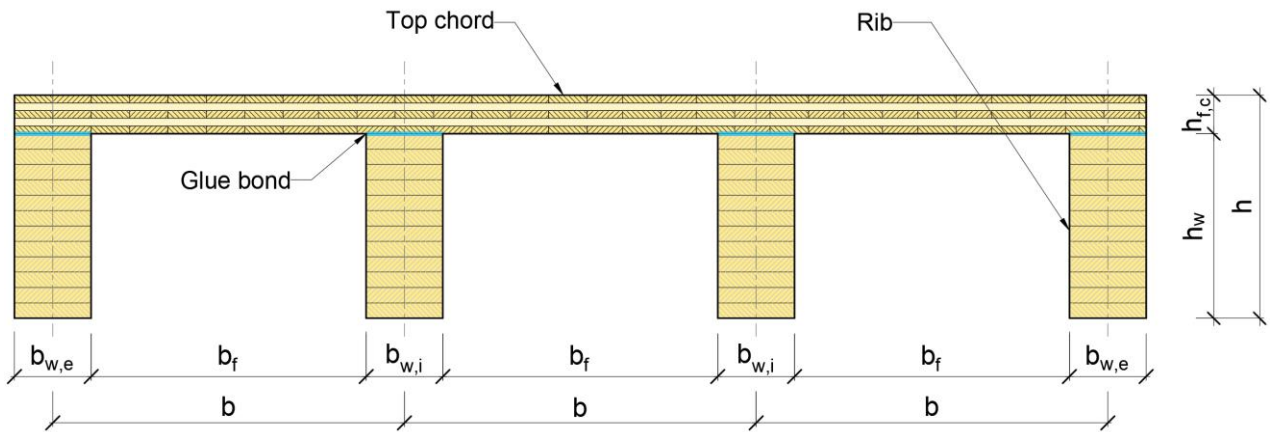

Figure 1: Sylva™ CLT Rib - Open, by Stora Enso

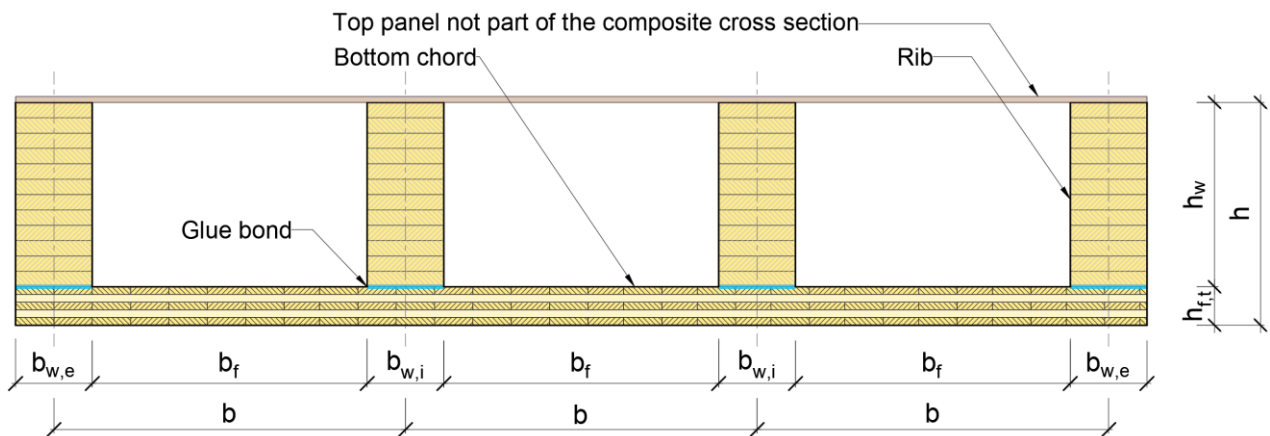

Figure 2: Sylva™ CLT Rib - Inverted, by Stora Enso

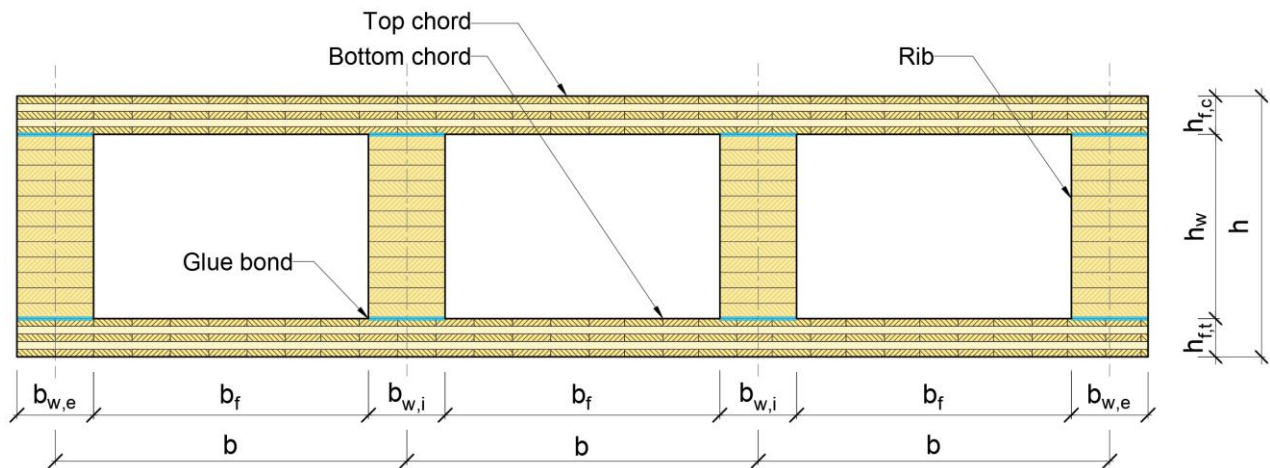

Figure 3: Sylva™ CLT Rib - Closed, by Stora Enso

Width top cord, $b_{f,t,tot}$ / width bottom cord, $b_{f,b,tot}$	< 3500 mm
Height top cord, $h_{f,t}$ / height bottom cord, $h_{f,b}$	60 – 200 mm
Material top/bottom cord ¹	C16, C24, C30
Depth rib, h_w	> 100 mm
Width rib, b_w	> 60 mm
Material rib ²	GL 20h – GL 32h and GL 20c – GL 32c
Rib spacing, b	variable

1 According to ETA-14/0349

2 According to EN 14080

2. Layout in plan view

All given layout recommendations are only valid for Sylva™ CLT Rib with ribs, oriented parallel to the direction of the CLT cover layer. Sylva™ CLT Rib may be used in all kinds of plan layouts. Still, they are usually used for rectangular layouts. If the axis between the longitudinal direction of skewed panels and the supporting line is $\alpha \geq 70^\circ$ (Fig. 1-2), the influence of the skewness can be neglected. The span of the system can be considered as the distance perpendicular to the supporting lines. In all other cases the influence of the supporting conditions shall be analyzed more detailed, by means of special methods (e. g. FEM).

For layouts with an irregular shape, the design shall be done using the longest distance between supporting lines as span. This shall be always measured parallel to the ribs (Fig. 1-3). As alternative, the design by means

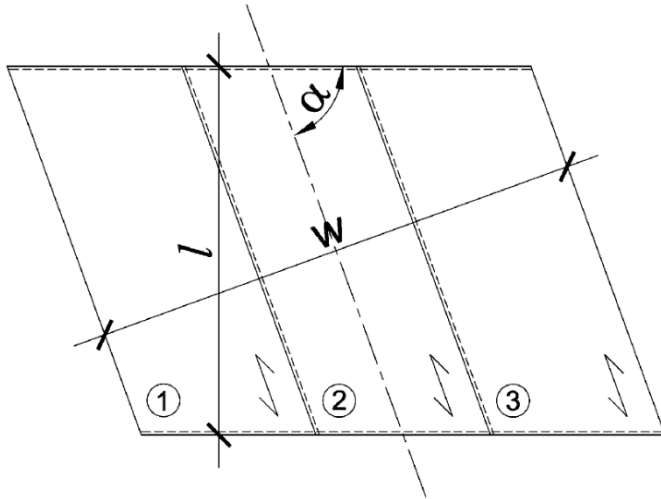

Figure 4: Sylva™ CLT Rib with skew cut layout in plan view

of special methods (e. g. FEM), is recommended.

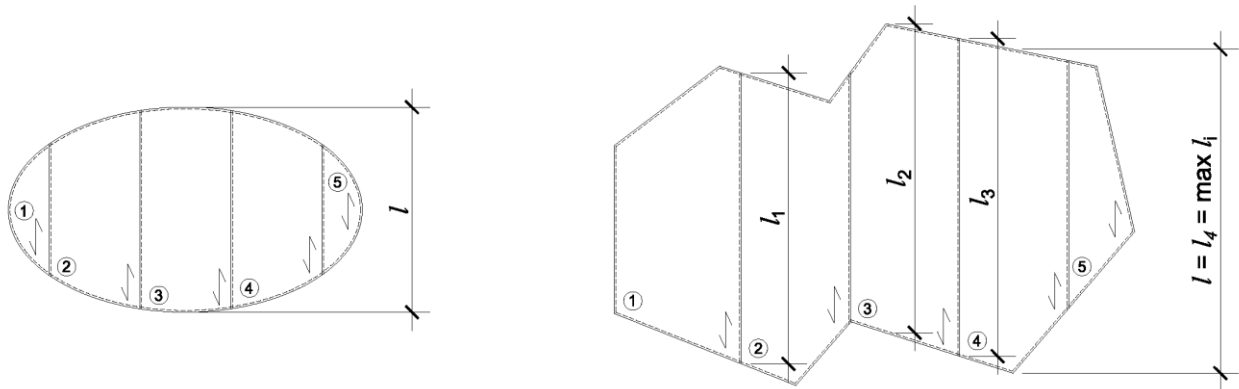

Figure 5: panels with elliptical (left) and irregular shape (right)

3. Tolerances of dimensions

Tolerances of dimensions at the reference moisture content of $10 \pm 2\%$ are presented in Table 2.

Dimension	Tolerance, mm or %
Depth $h_{\text{rib}} \leq 400\text{mm}$ $h_{\text{rib}} > 400\text{mm}$	-2 / +4 mm $-0.5\% \cdot h / +1\% \cdot h$
Width of the Sylva™ CLT Rib elements	-2 / +2 mm
Length of the Sylva™ CLT Rib elements	± 5 mm

Table 2: Tolerances of Sylva™ CLT Rib.

4. Specifications of components

CLT slabs:

CLT slabs are made of CLT by Stora Enso according to ETA-14/0349. The material properties and strength values according to ETA-14/0349 shall be used in design.

Glued laminated timber ribs:

Glued laminated timber according to EN 14080 may be made by any manufacturer. Glulam class is to be given in the design. The material properties and strength values according to EN 14080 shall be used in design.

Adhesive:

The adhesive used in manufacturing of Sylva™ CLT Rib to attach the rib to the CLT slab, is one component polyurethane adhesive as defined in EN 15425 or a MUF adhesive according to EN 301 and shall conform to type I according to EN 15425 or EN 301. The adhesive used shall be approved for gluing of load-bearing structures.

5. Typical support types

Some possible types of supports, where the Sylva™ CLT Rib elements is supported off the rib. This is considered the standard situation.

Open Sylva™ CLT Rib - Simple support

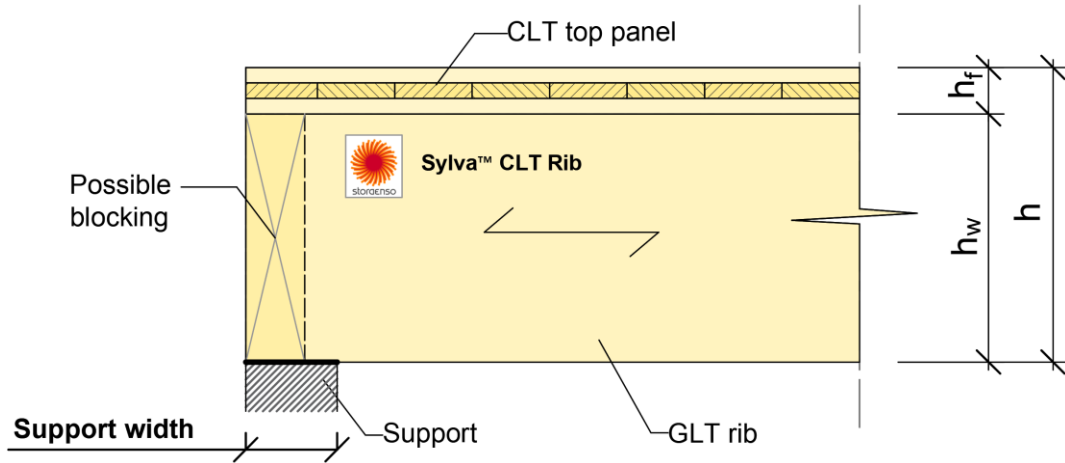

Inverted Sylva™ CLT Rib - Simple support

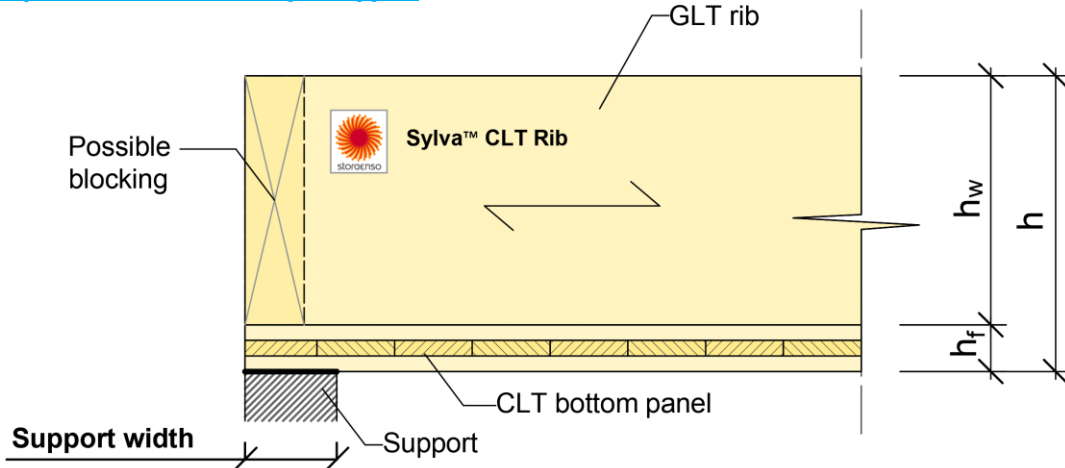

Closed Sylva™ CLT Rib - Simple support

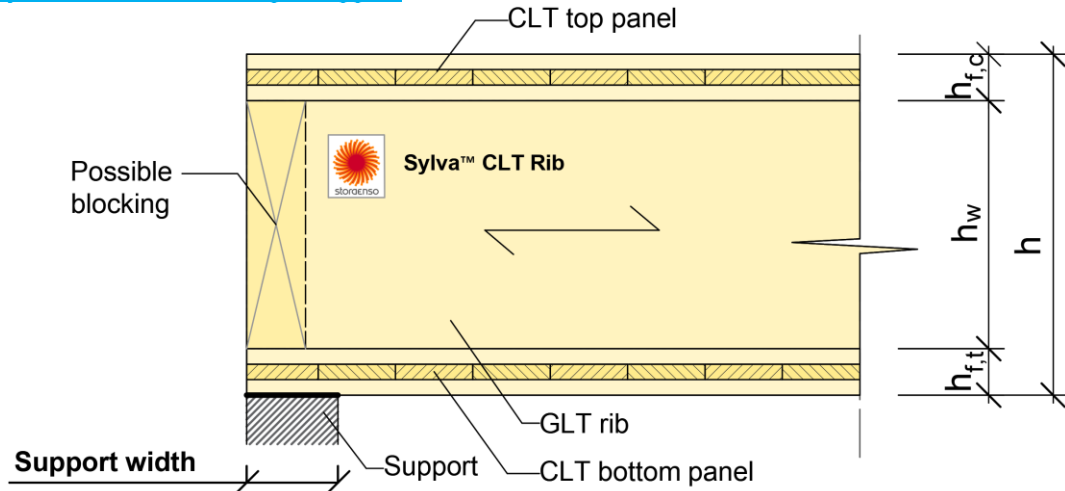
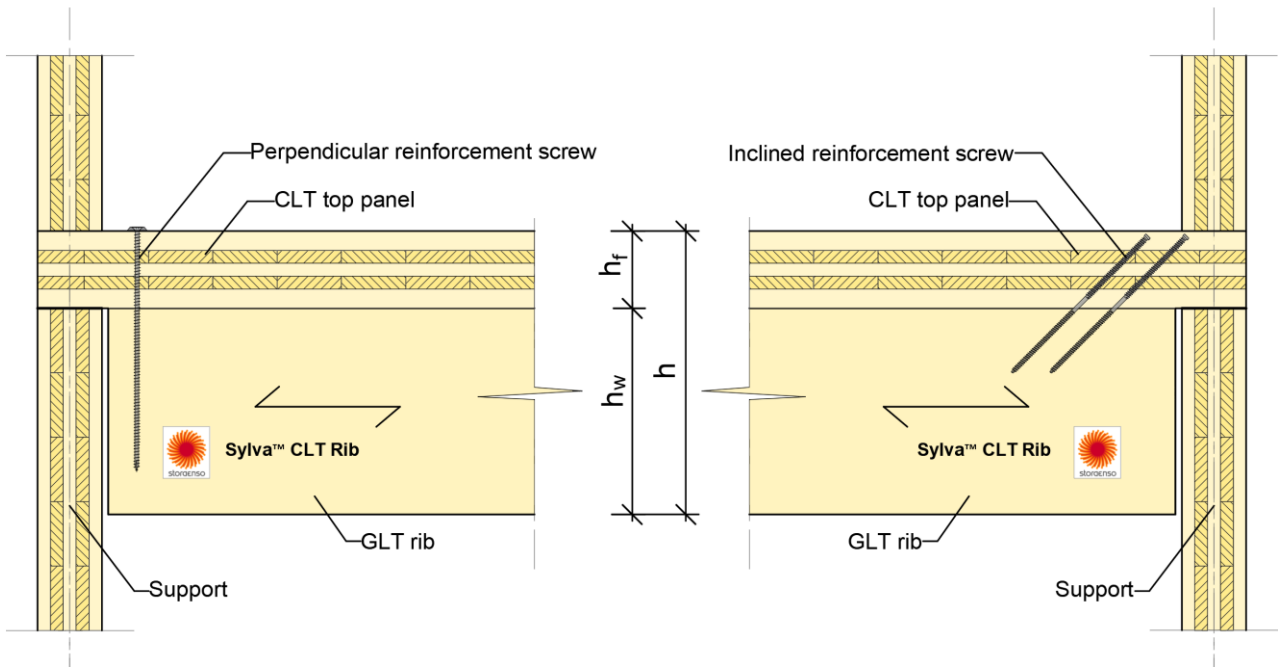

Figure 6: Simple support type

[Open Sylva™ CLT Rib - Support by the CLT top panel](#)



[Closed Sylva™ CLT Rib - Support by the CLT top panel](#)

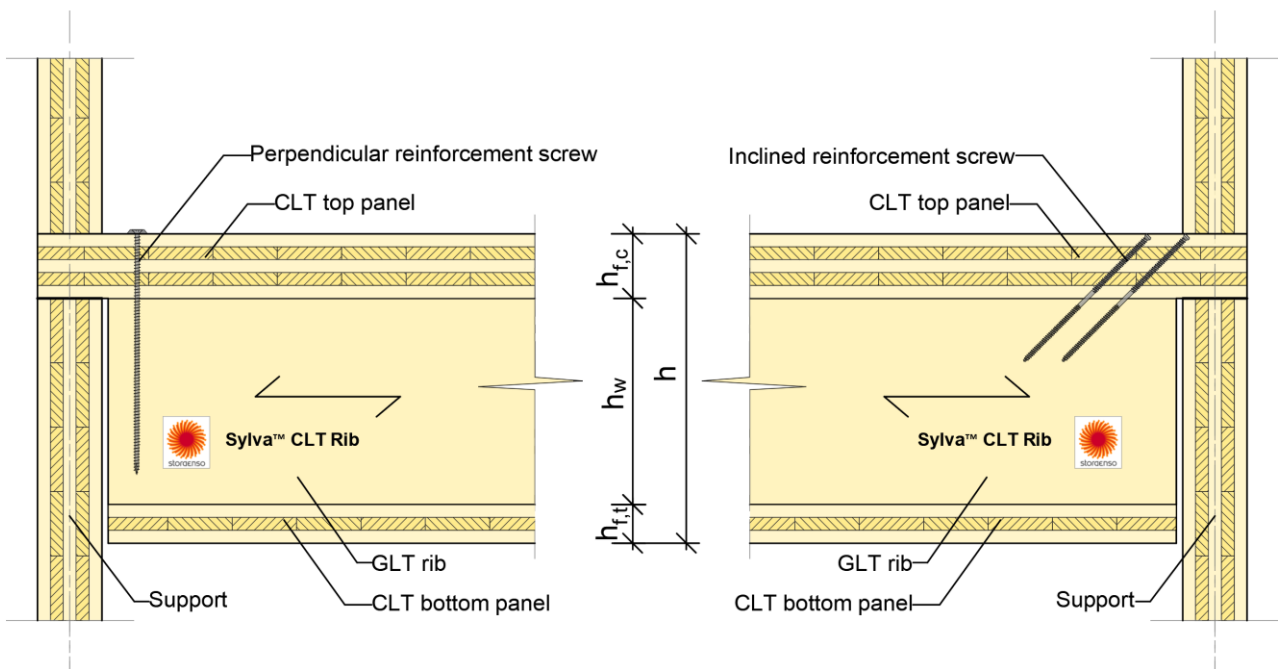
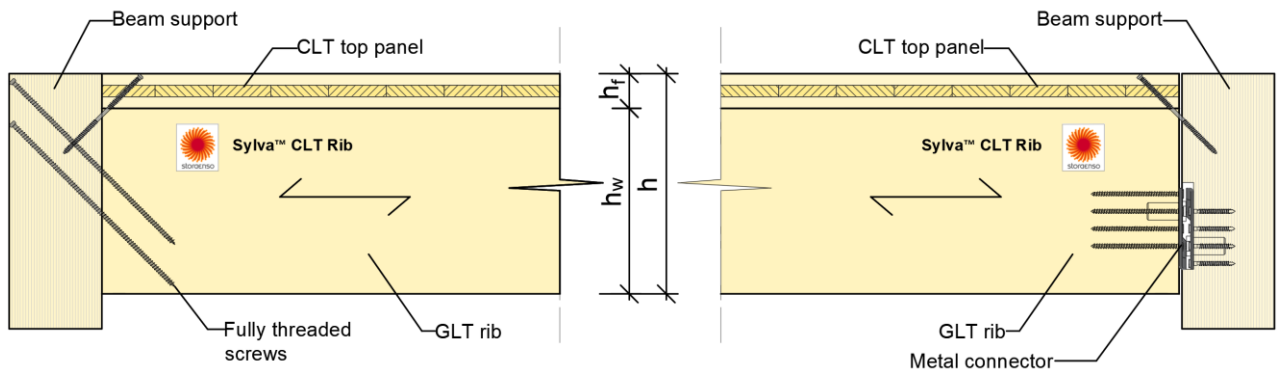

Figure 7: Supported by the top panel

[Open Sylva™ CLT Rib - End beam support with metal connectors](#)



[Open Sylva™ CLT Rib - End beam support with metal connectors](#)

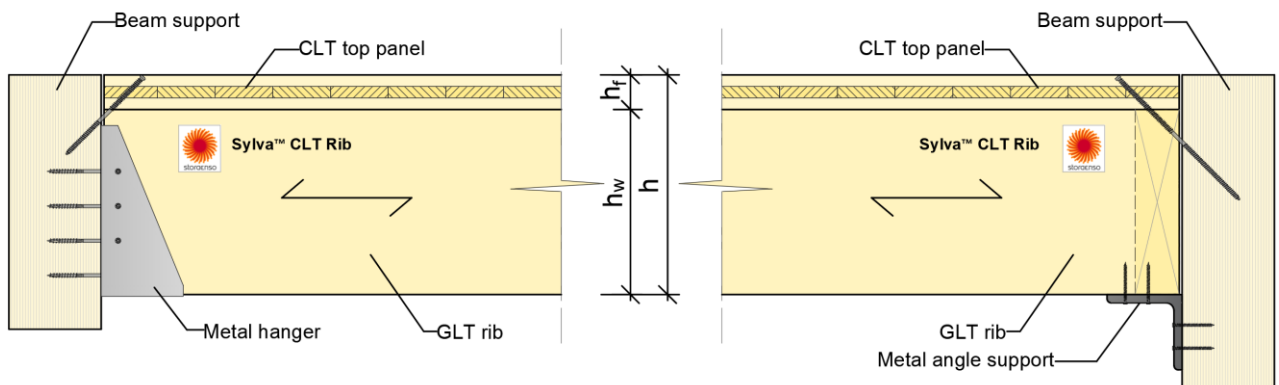
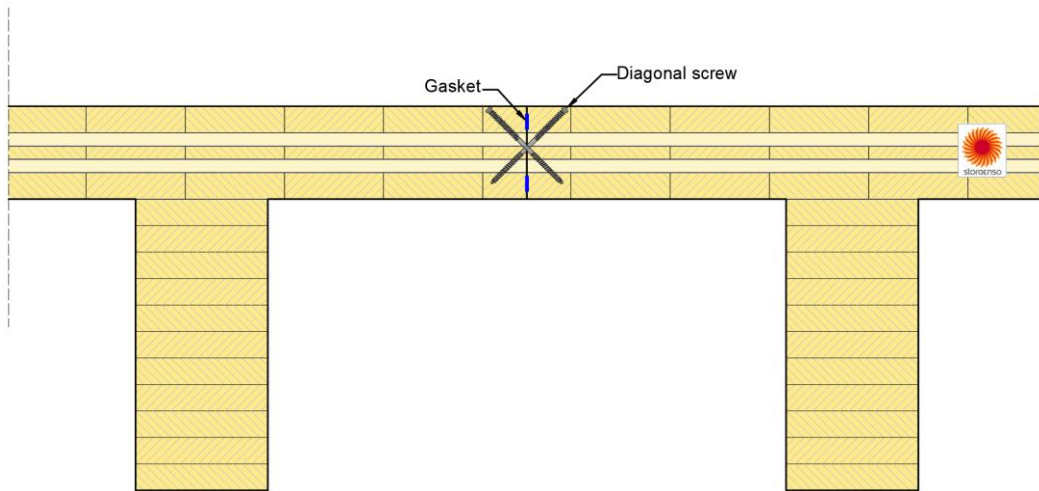

Figure 8: Support with metal connectors

6. Typical connections between adjacent Sylva™ CLT Rib

A typical splice between two Sylva™ CLT Rib elements is a lap splice in the CLT panel, as shown in the figure below. If there are any requirements towards airtightness, a gasket can be placed in the joint.

[Open Sylva™ CLT Rib - Butt joint with edge rib offset](#)



[Open Sylva™ CLT Rib - Butt joint with edge rib](#)

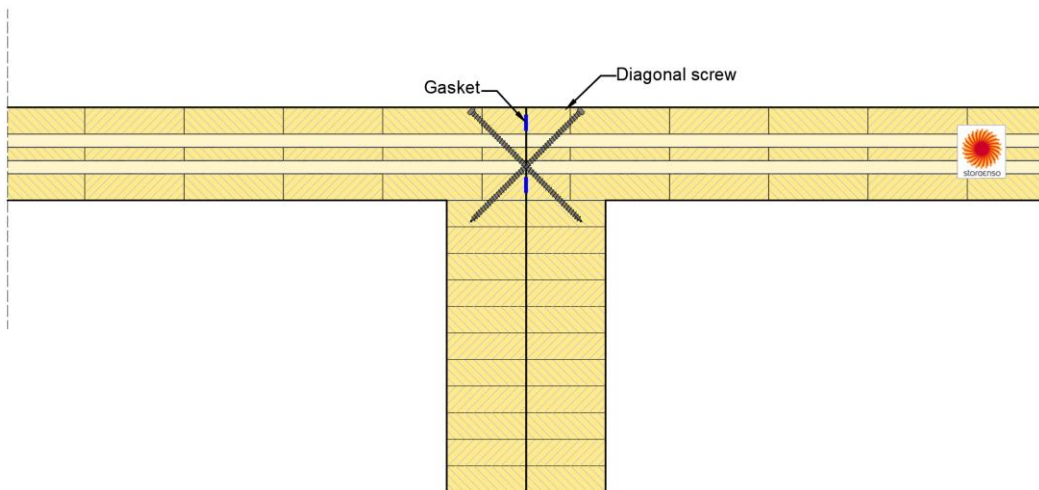

[Open Sylva™ CLT Rib - Lap joint with edge rib offset](#)

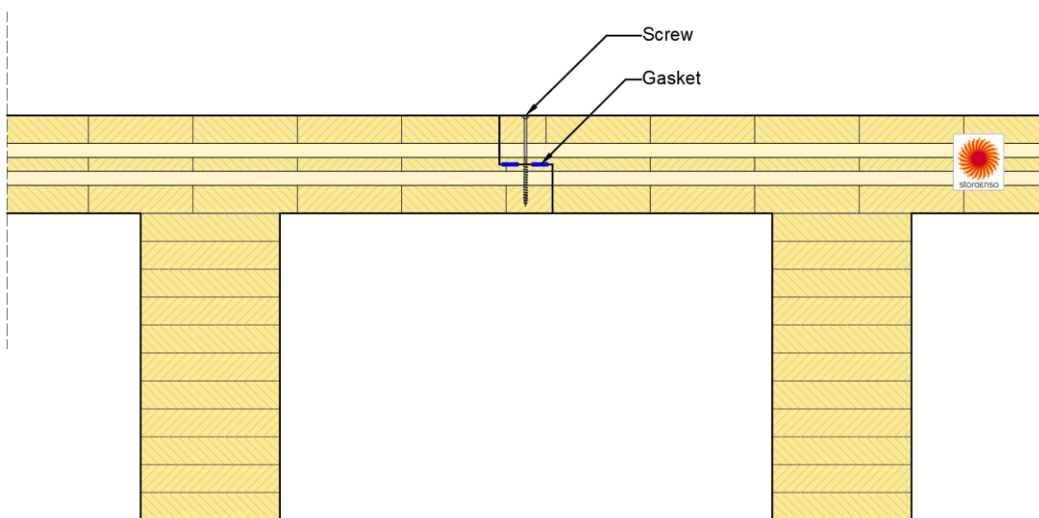
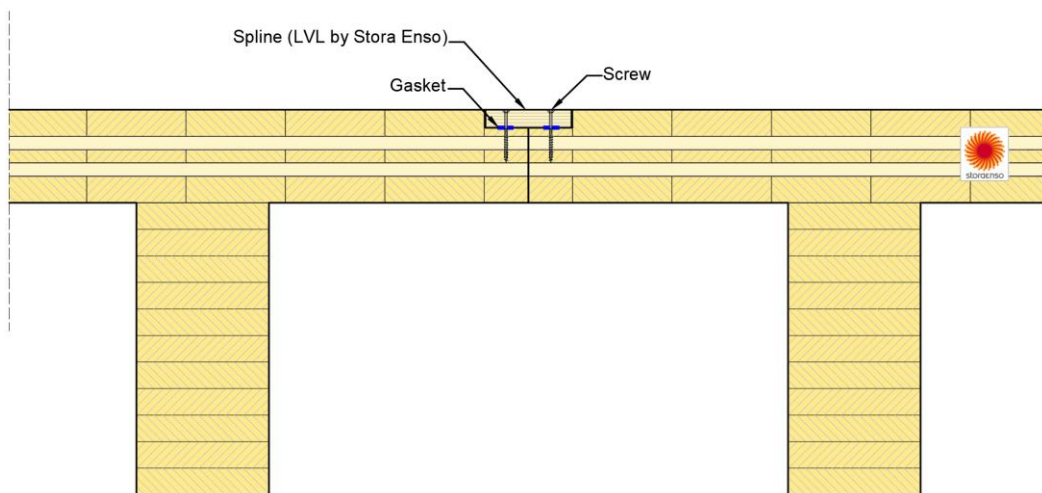
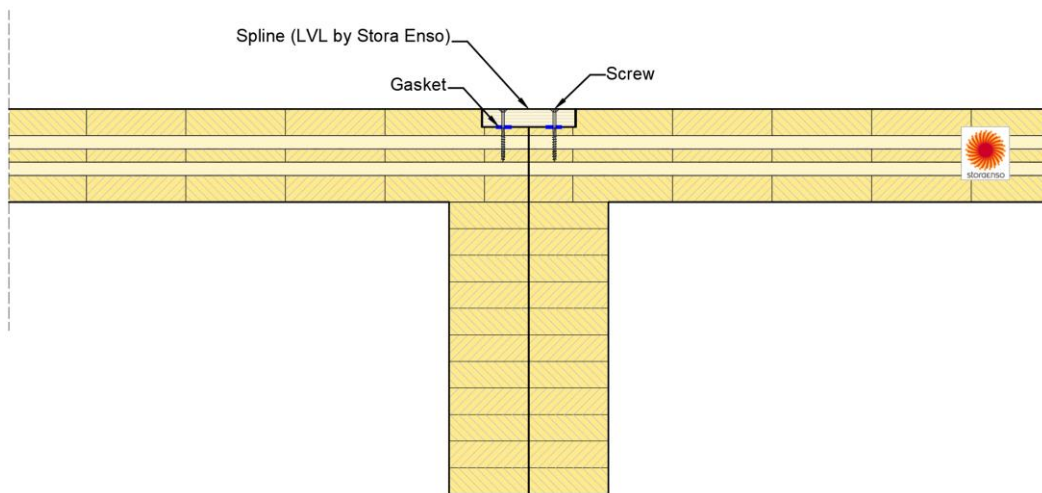

Figure 9: Butt joint + Lap joint

[Open Sylva™ CLT Rib - Single shear plane spline joint with edge rib offset](#)



[Open Sylva™ CLT Rib - Single shear plane spline joint with edge rib](#)



[Open Sylva™ CLT Rib - Double shear plane spline joint with edge rib offset](#)

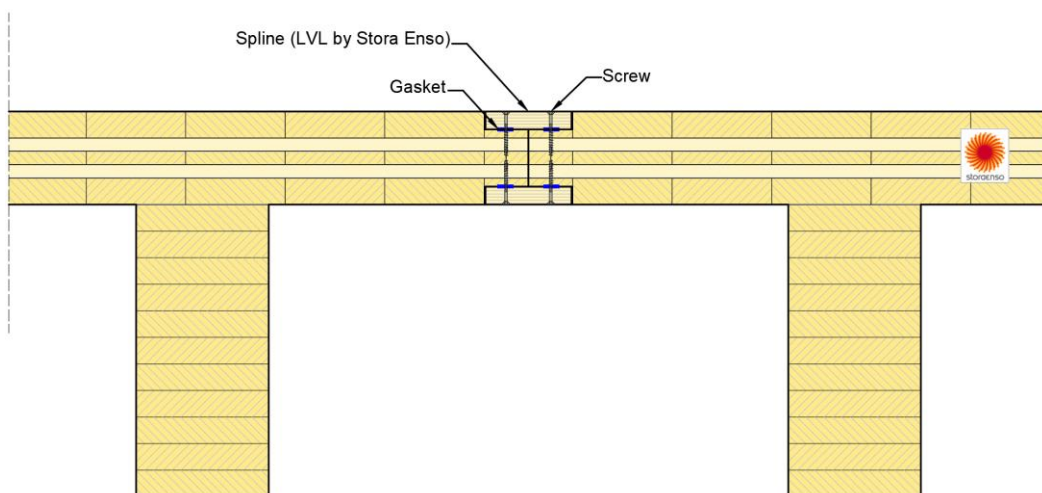

Figure 10: Spline joint

Other joint types are possible if the applicable shear force in vertical and horizontal direction can be transferred.

Annex 2
STRUCTURAL ANALYSIS OF Sylva™ CLT Rib

1. General design assumptions

The connection between the CLT panel and the rib is to be assumed as rigid, as it is glued. The gluing pressure can be applied by a hydraulic press or the applying screw press-gluing.

The CLT rib panel design in ultimate limit state (ULS) shall be done, based on a solid cross section, considering b_{ef} as effective or tributary width in the flange. A different modulus of elasticity in the used components (ribs and CLT), has to be considered in design.

$$b_{ef} = b_w + \sum b_{ef,i} < b$$

Equation 1: effective width

with

b_{ef} effective or tributary width of the flange in the Sylva™ CLT Rib element [mm]

b_w width of the rib [mm]

$b_{ef,i}$ effective width at each side of the rib ($i=1,2$) [mm]

[Sylva™ CLT Rib - Open, by Stora Enso \(with edge rib\)](#)

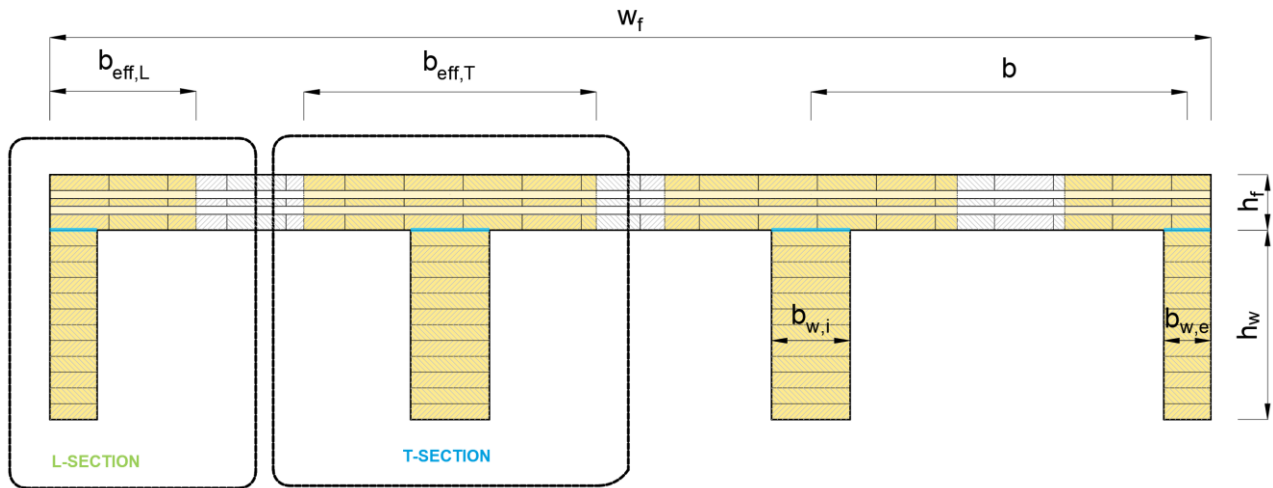

[Sylva™ CLT Rib - Closed, by Stora Enso \(with edge rib\)](#)

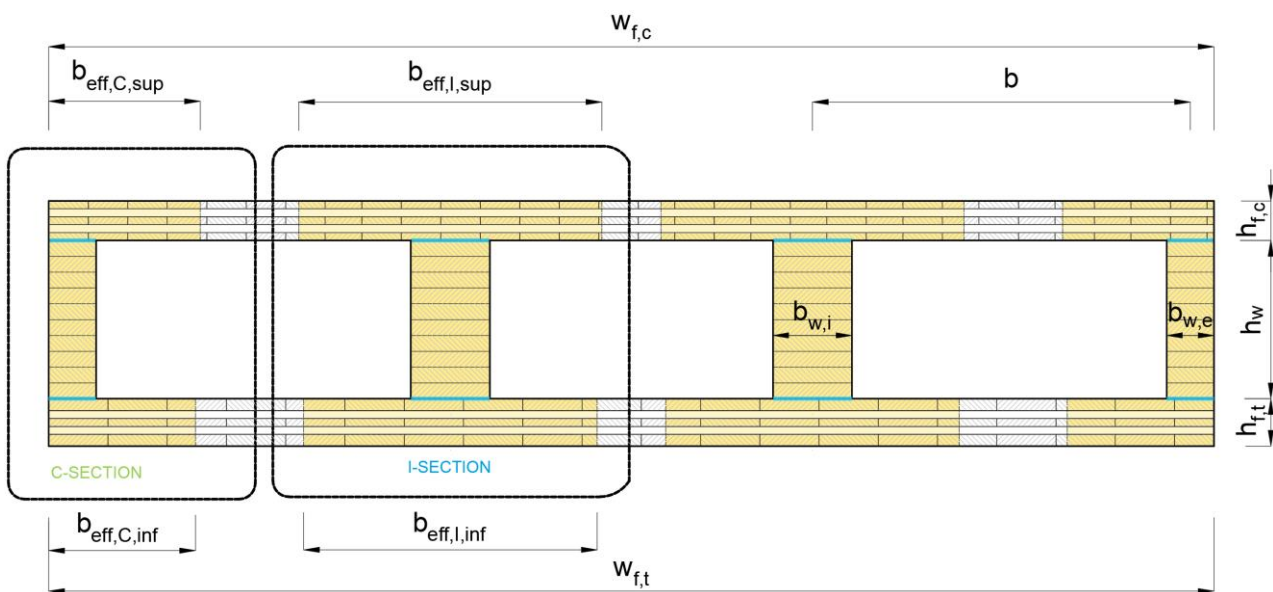

Figure 11: Tributary width (example with edge rib)

The given equations are valid for the range of application:

- ratio between clear distance between ribs and span: $b_f / L = 0.02$ to 0.25
for $b_f / L < 0.02$: $b_f = b$
- ratio of the in-plane axial stiffness in the direction of the span to the (effective) shear stiffness:

$$\frac{(EA)_x}{S_{xy}^*} = 5 \text{ to } 22$$

Equation 2: stiffness ratio

$$S_{xy}^* = \frac{G_{0,mean} \cdot t}{1 + 6 \cdot p_s \cdot \left(\frac{t_{max}}{a}\right)^{q_s}}$$

Equation 3: in-plane shear stiffness of CLT panels

With

$(EA)_x$	in-plane axial stiffness of the CLT panel, in the principal direction of the panel $(EA)_x = \sum E_{i,0} \cdot b_{ef} \cdot t_{i,x}$ [N/m]
S_{xy}^*	in-plane shear stiffness of CLT panels [N/m]
$G_{0,mean}$	mean value of the shear modulus, parallel to the grain [N/mm ²]
t	total thickness of the CLT panel
t_{max}	maximum thickness of an individual CLT layer [mm]
a	mean value of the width of the lamination boards (if unknown, a width of $a = 80$ mm shall be applied)

p_s, q_s

parameters	p_s	q_s
3-layer CLT	0.53	1.21
5-layer CLT	0.43	1.21
7-layer CLT	0.43	1.21

- ratio of span and the total height of the member: $L / h = 14$ to 25
- for the span L , the distance between zero moments should be used
- For locally acting loads with a load introduction point $\leq b$ to a zero moment or if $c_p < 0,05 \cdot L$, the effective width should be considered as $b_{ef,i} = 0$ (with c_p ... length of the distributed load)
- effective width b_{ef} , for a dominating continuous load:

$$b_{ef,i} = b_{f,j} \cdot \min \left\{ 0.5 - 0.35 \cdot \left(\frac{b_{f,j}}{L}\right)^{0.9} \cdot \left(\frac{(EA)_x}{S_{xy}^*}\right)^{0.45} \right.$$

Equation 4: effective width $b_{ef,i}$

With

$b_{ef,i}$	effective width at each side of the rib [mm]
$b_{f,j}$	clear distance between the ribs [mm]
L	span [mm]

- effective width b_{ef} , for a dominating point load:

$$2 \leq \frac{h_w}{h_f} < 3: \quad b_{ef,i} = b_{f,j} \cdot \min \left\{ 0,5 - 0,30 \cdot \left(\frac{b_{f,j}}{l}\right)^{0,25} \cdot \left(\frac{(E \cdot A)_x}{S_{xy}^*}\right)^{0,25} \right.$$

Equation 5: effective width $b_{ef,i}$ for a height ratio between the rib and the CLT $2 \leq \frac{h_w}{h_f} < 3$

$$3 \leq \frac{h_w}{h_f} \leq 5: \quad b_{ef,i} = b_{f,j} \cdot \min \left\{ 0,5 - 0,36 \cdot \left(\frac{b_{f,j}}{l} \right)^{0,40} \cdot \left(\frac{(E \cdot A)_x}{S^*_{xy}} \right)^{0,25} \right.$$

Equation 6: effective width $b_{ef,i}$ for a height ratio between the rib and the CLT $3 \leq \frac{h_w}{h_f} \leq 5$

With

h_w height of the rib [mm]
 h_f height of the CLT [mm]

- effective bending stiffness $(EI)_{y,ef}$:

$$(EI)_{y,ef} = \sum_{i=1}^n E_i \cdot \frac{b_{ef,i} \cdot h_i^3}{12} + \sum_{i=1}^n E_i \cdot b_{ef,i} \cdot h_i \cdot z_i^2$$

Equation 7: effective bending stiffness of the Sylva™ CLT Rib element [Nmm²]

With

EI mean modulus of elasticity, of the respective partial section i in the cross section [N/mm²]
 $b_{ef,i}$ Effective width, of the respective partial section i in the cross section [mm]
 h_i height, of the respective partial section i in the cross section [mm]
 z_i eccentricity (= distance from the centre of gravity on the partial section i to the centre of gravity of the entire composite section), of the respective partial section i in the cross section [mm]

2. Modification factor k_{mod}

Modification factors consider the influence of load duration and moisture content on strength. Recommended values for Sylva™ CLT Rib elements are given in the table below:

Service class	CLT and glued laminated timber				
	Load duration class				
	Permanent action	Long term action	Medium term action	Short term action	Instantaneous action
1	0.60	0.70	0.80	0.90	1.10
2	0.60	0.70	0.80	0.90	1.10

Table 3: modification factor k_{mod}

If a load combination consists of actions belonging to different load-durations classes, a value of k_{mod} should be chosen which corresponds to the action with the shortest duration.

3. Deformation factor k_{def}

Deformation factor k_{def} considers the influence of load-duration (creep) and moisture influences on deformations.

Recommended values for Sylva™ CLT Rib elements are given in the table below:

	Service class	
	1	2
Glued laminated timber	0.60	0.80
CLT	0.80	1.00

Table 4: recommended deformation factor k_{def} for the respective material

Ideally the applicable deformation factor is being applied to the very material in the design. The following simplification shall be allowed:

$$k_{def} = \sqrt{k_{def,GLT} \cdot k_{def,CLT}}$$

With

k_{def}	Global deformation factor for the entire Sylva™ CLT Rib element [-]
$k_{def,GLT}$	Deformation factor for glued laminated timber [-]
$k_{def,CLT}$	Deformation factor for CLT [-]

4. Recess at support

Typically, Sylva™ CLT Rib element are supported off their ribs, as indicated in Annex 1, item 5. If the rib shall stop before the support line, the recess and the splitting reinforcement shall be designed as follows.

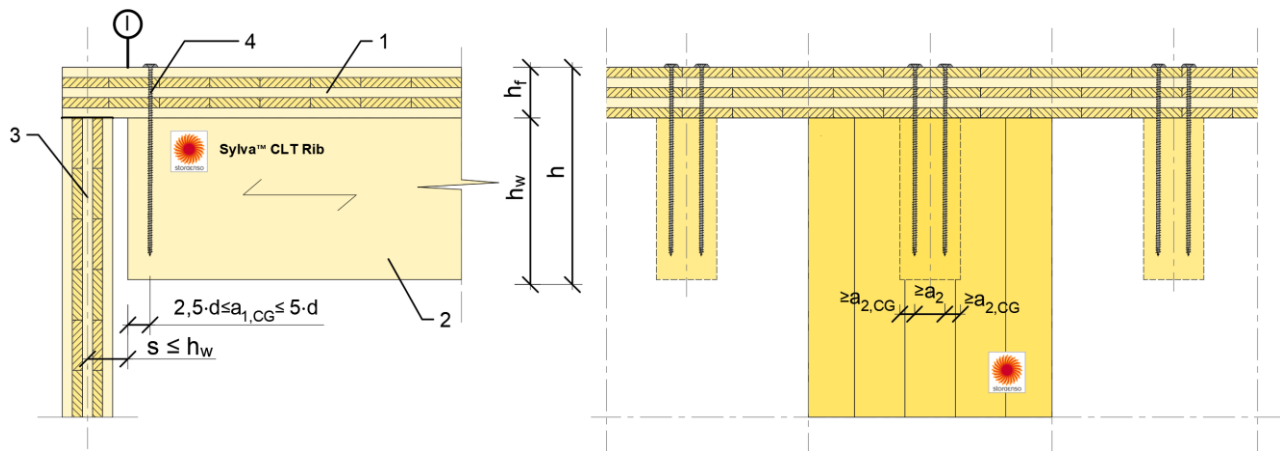

Figure 12: Support by the CLT top panel

- (1) CLT panel
- (2) rib
- (3) any kind of support (CLT wall in this case)
- (4) reinforcement (fully threaded screw)

Boundary conditions:

- Maximum distance between support edge (or interior face of wall) and end face of the rib shall be $s \leq h_w$
- Splitting reinforcement is required (e.g. glued-in rods, fully threaded screws, etc.).
- Only 1 row of reinforcement along the longitudinal axis of the rib.
- Edge distance of the splitting reinforcement needs to be as follows:
towards end face: $2.5 \cdot d \leq a_{1,CG} \leq 5.0 \cdot d$ (d = reinforcement diameter)
- More than 1 reinforcement can be placed in perpendicular direction to the rib axis.
The applicable connector spacing a_2 and edge distances $a_{2,CG}$ need to be provided.

Required structural design at the recess:

- Bending stress, shear and rolling shear stress to be analyzed within the CLT section, at the point, where the rib ends.
- The splitting force (tension perpendicular to the grain), that the reinforcement has to resist (valid for $1.5 \leq \gamma_{rib} \leq 150$ and $0.1 \leq s / h \leq 1.0$)

$$F_{t,90,d} = V_{red,0,d} \cdot k_s = V_{red,0,d} \cdot \frac{1}{1 + \frac{0.3}{\sqrt{\gamma_{rib}}} - 0.35 \cdot \sqrt{\frac{s}{h}}}$$

Equation 8: splitting force

with

$F_{t,90,d}$ Design value of the splitting force, that the reinforcement must resist [N]

$V_{red,0,d}$ Design value of the shear force in the rib, without recess [N],
valid for $5 \leq L/b \leq 32$ and $1.5 \leq \gamma_{rib} \leq 150$

$$V_{red,0,d} = \underbrace{q_d \cdot \frac{b \cdot L}{2}}_{V_{tot,d}} \cdot \left(1.2 - 0.05 \cdot \sqrt{\frac{L}{b}} - \frac{0.5}{\sqrt{\gamma_{rib}}} \right)$$

q_d Design value of the continuously distributed load on [N/mm²]

k_s Reduction factor, considering the distance between rib end and support line [-]

$$k_s = \frac{1}{1 + \frac{0.3}{\sqrt{\gamma_{rib}}} - 0.35 \cdot \sqrt{\frac{s}{h}}}$$

s distance between rib end and support line [mm]

h Total height of the CLT rib panel [mm]

γ_{rib} Rib rigidity ratio [-]

$$\gamma_{rib} = \frac{(EI)_{rib}}{(EI)_{y,ef}} = \frac{b_w \cdot h_w^3}{12 (EI)_{y,ef}}$$

$(EI)_{y,ef}$ Effective bending stiffness of the Sylva™ CLT Rib element [Nmm²] per equation 7.

Annex 3 Acoustic performance of Sylva™ CLT Rib

The acoustic performance for airborne and impact sound was tested on the following buildups.

1. Sylva™ CLT Rib – open; no floor build-up, no ceiling

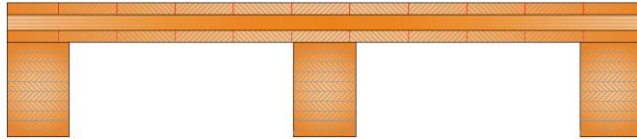

100 mm CLT
160 x 240 mm Glulam

R_w	36 dB	$L_{n,w}$	91 dB
C	-1 dB	C_I	-6 dB
C_{tr}	-4 dB	$C_{I,50}$	-6 dB

2. Sylva™ CLT Rib– open; floating cement screed, no ceiling structure

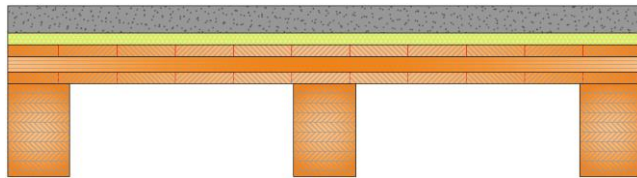

70 mm cement screed
30 mm impact sound insulation, mineral wool
100 mm CLT
160 x 240 mm glued laminated timber rib

R_w	60 dB	$L_{n,w}$	65 dB
C	-2 dB	C_I	-5 dB
C_{tr}	-5 dB	$C_{I,50}$	-2 dB

3. Sylva™ CLT Rib – open; floating cement screed, suspended ceiling structure

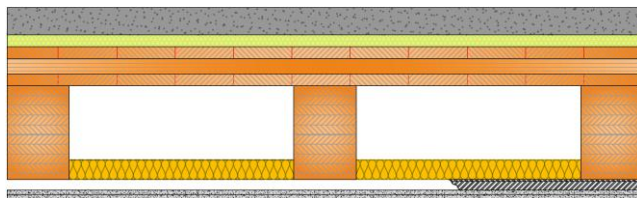

70 mm cement screed
30 mm impact sound insulation, mineral wool
100 mm CLT
160 x 240 mm glued laminated timber rib
50 mm mineral wool
27 mm resilient metal channel
12.5 mm gypsum plasterboard
12.5 mm gypsum plasterboard

R_w	75 dB	$L_{n,w}$	47 dB
C	-1 dB	C_I	-3 dB
C_{tr}	-6 dB	$C_{I,50}$	7 dB

4. Sylva™ CLT Rib – open; dry screed, no ceiling structure

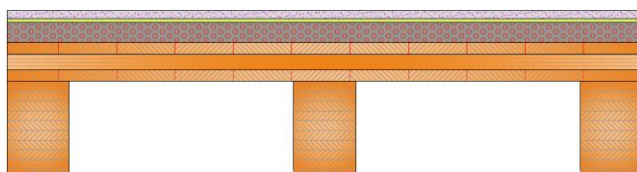

20 mm dry screed, consisting of 20 mm gypsum fibre boards
10 mm impact sound insulation, wood fibre board
50 mm gravel
100 mm CLT
160 x 240 mm glued laminated timber rib

R_w	58 dB	$L_{n,w}$	60 dB
C	-4 dB	C_I	1 dB
C_{tr}	-11 dB	$C_{I,50}$	1 dB

5. Sylva™ CLT Rib – open; dry screed, suspended ceiling structure

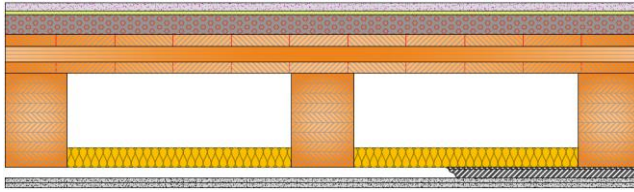

20 mm dry screed consisting of 20 mm gypsum fibre boards
 10 mm impact sound insulation, mineral wool
 50 mm gravel
 100 mm CLT
 160 x 240 mm glued laminated timber rib
 50 mm mineral wool
 27 mm resilient metal channel
 12.5 mm gypsum plasterboard
 12.5 mm gypsum plasterboard

R_w	69 dB	$L_{n,w}$	45 dB
C	-6 dB	C_I	3 dB
C_{tr}	-14 dB	$C_{I,50}$	9 dB

Annex 4

Fire performance of Sylva™ CLT Rib

The fire performance was tested on the flowing buildups.

1. Sylva™ CLT Rib – open; no ceiling structure

CLT ribbed slabs were made of 120 mm thick CLT 120 L3s cover boards and GLT 200/280 ribs (b x h = 200 mm x 280 mm, grade GL 24h) glued and screwed together (Würth Assy 3.0 SK 8x220, c/c 160mm). There were two ribs on 2004 mm wide element and one rib on 1071 mm wide element. There were a non-loadbearing GLT 100/180 ribs, cut every 300 mm (b x h = 100 mm x 280 mm, grade GL 24h) on the both long edges of the specimen.

The two elements were connected together by screwing the CLT 120 L3s cover boards at the joint (HBS 6X100, c/c 250mm). The width of the joint was 77mm and the joint was sealed with two lines of Fire stop sealant (Hilti CFS-S ACR).

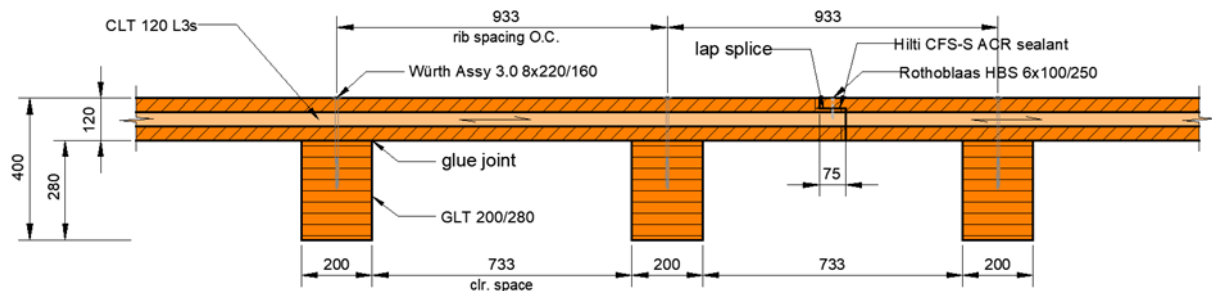

The following classes are applicable for floor construction when the maximum moment of 46.47 kNm/m of the floor is not exceeded.

The CLT rib panel – open; no ceiling structure is classified as **REI 90, RE 90 and R 90** in accordance with EN 13501-2

The applicable field of application is:

- The maximum moments and shear forces, which when calculated on the same basis as the test load, shall not be greater than those tested.
- The size of panels of the ceiling lining may be increased by a maximum of 5 % but limited to a maximum of 50 mm. The length of the grid members can be increased accordingly.
- The total area occupied by fixtures and fittings relative to the area of the ceiling lining is not increased and the maximum tested opening in the lining is not exceeded.
- The height of the cavity (h) and the minimum distance (d) between the ceiling and the structural members (see drawing above) are equal to or greater than those tested.
- No material is added to the cavity.

2. Sylva™ CLT Rib – open; with a gypsum board ceiling structure

CLT ribbed slabs were made of 120 mm thick CLT 120 L3s cover boards and GLT 180/240 ribs (b x h = 180 mm x 240 mm, grade GL 24h) glued and screwed together (Würth Assy 3.0 SK 8x220, c/c 180mm). There were two ribs on 2004 mm wide element and one rib on 1071 mm wide element. There were non-loadbearing GLT 100/240 ribs, cut every 300 mm (b x h = 100 mm x 240 mm, grade GL 24h) on the both long edges of the specimen.

The two elements were connected together by screwing the CLT 120 L3s cover boards at the joint (HBS 6X100, c/c 250mm). The width of the joint was 77mm and the joint was sealed with two lines of sealing strip (Würth DIBA-(VKP-PLUS)-(15/3)-Grau-10m). The size of the construction was 3000 mm x 5300 mm and the span was 5200 mm.

Rigips steel profiles (Hutfederschiene 60/27) c/c 400 mm were fixed under the ribs. Two layers of Rigips RF gypsum boards (nominal thickness 12.5 mm, measured weight 10.5 kg/m²) were fixed underneath the steel profiles with joints staggered. The joint between the gypsum boards and frame was sealed with (Hilti CFS-S ACR) Fire Stop Sealant.

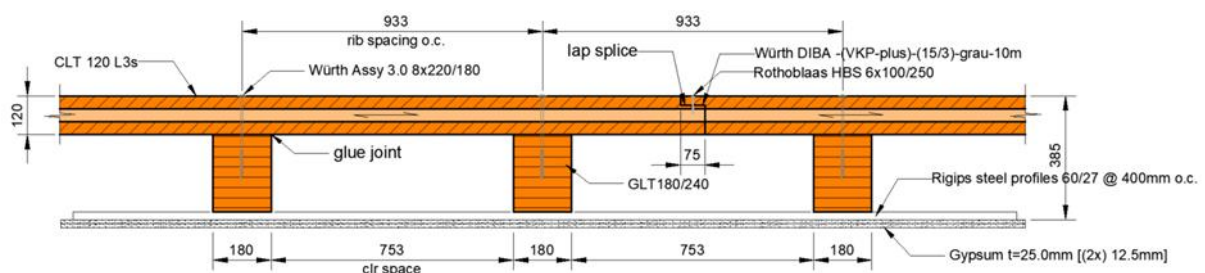

The following classes are applicable for floor construction when the maximum moment of 48.80 kNm/m of the floor is not exceeded.

The CLT rib panel – open; with a gypsum board ceiling structure is classified as **REI 90, RE 90 and R 90** in accordance with EN 13501-2

The applicable field of application is:

- The maximum moments and shear forces, which when calculated on the same basis as the test load, shall not be greater than those tested.
- The size of panels of the ceiling lining may be increased by a maximum of 5 % but limited to a maximum of 50 mm. The length of the grid members can be increased accordingly.
- The total area occupied by fixtures and fittings relative to the area of the ceiling lining is not increased and the maximum tested opening in the lining is not exceeded.
- The height of the cavity (h) and the minimum distance (d) between the ceiling and the structural members (see drawing above) are equal to or greater than those tested.
- No material is added to the cavity.

3. Sylva™ CLT Rib – closed; no ceiling structure

CLT ribbed slabs were made of 90 mm thick CLT 90 L3s cover boards on the top side and 60 mm thick CLT 60 L3s cover boards on the bottom side of the GLT 180/200 ribs ($b \times h = 180 \text{ mm} \times 200 \text{ mm}$, grade GL 24h) glued and screwed together (Würth Assy 3.0 SK 8x180, c/c 180mm). There were two ribs on 2004 mm wide element and one rib on 1071 mm wide element.

There were a non-loadbearing GLT 100/200 ribs, cut every 300 mm ($b \times h = 100 \text{ mm} \times 200 \text{ mm}$, grade GL 24h) on both the long edges of the specimen.

The two elements were connected together by screwing the CLT 90 L3s cover boards at the joint (Berner 6X70, c/c 250mm) and the CLT 60 L3s cover boards at the joint (HBS 6X60, c/c 250mm). The width of the joint was 75mm and the joint was sealed with one line of sealing strip (Würth DIBA-(VKP-PLUS)-(15/3)-Grau-10m). The size of the construction was 3000 mm x 5300 mm and the span was 5200 mm.

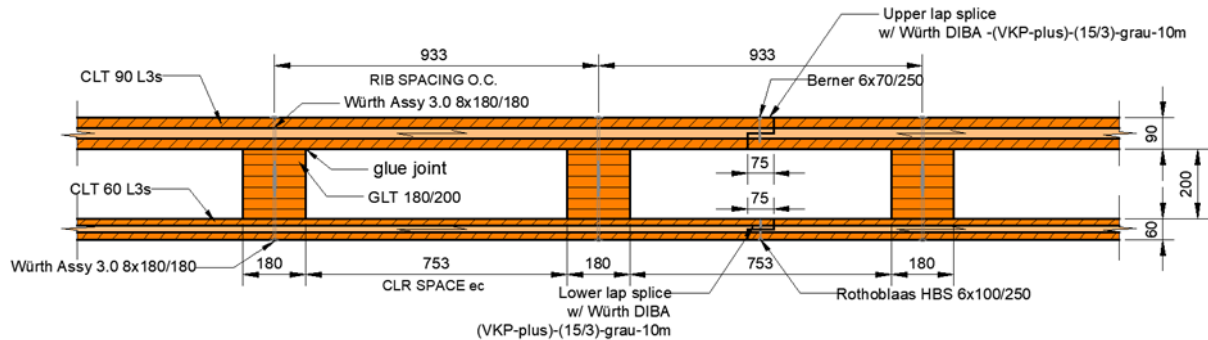

The following classes are applicable for floor construction when the maximum moment of 48.64 kNm/m of the floor is not exceeded.

The CLT rib panel – closed; no ceiling structure is classified as **REI 90, RE 90 and R 90** in accordance with EN 13501-2

The applicable field of application is:

- The maximum moments and shear forces, which when calculated on the same basis as the test load, shall not be greater than those tested.
- The size of panels of the ceiling lining may be increased by a maximum of 5 % but limited to a maximum of 50 mm. The length of the grid members can be increased accordingly.
- The total area occupied by fixtures and fittings relative to the area of the ceiling lining is not increased and the maximum tested opening in the lining is not exceeded.
- The height of the cavity (h) and the minimum distance (d) between the ceiling and the structural members (see drawing above) are equal to or greater than those tested.
- No material is added to the cavity.

4. Sylva™ CLT Rib – closed; with a gypsum board ceiling structure

CLT ribbed slabs were made of 80 mm thick CLT 80 L3s cover boards on both sides of the GLT 120/160 ribs ($b \times h = 120 \text{ mm} \times 160 \text{ mm}$, grade GL 24h) glued and screwed together (Würth Assy 3.0 SK 8x180, c/c 250mm). There were two ribs on 2004 mm wide element and one rib on 1071 mm wide element. There were a non-loadbearing GLT 100/160 ribs, cut every 300 mm ($b \times h = 100 \text{ mm} \times 160 \text{ mm}$, grade GL 24h) on the both long edges of the specimen.

The two elements were connected together by screwing the CLT 80 L3s-A cover boards at the joint (Berner 7X700, c/c 250mm). The width of the joint was 77mm and the joint was sealed with one line of sealing strip (Würth DIBA-(VKP-PLUS)-(15/3)-Grau-10m). The size of the construction was 3000 mm x 5300 mm and the span was 5200 mm.

A layer of Rigips RF gypsum boards (nominal thickness 12.5 mm, measured weight 10.5 kg/m²) were fixed underneath the lower CLT 80 L3s-A cover board. The joint between the gypsum boards and frame was sealed with (Hilti CFS-S ACR) Fire Stop Sealant.

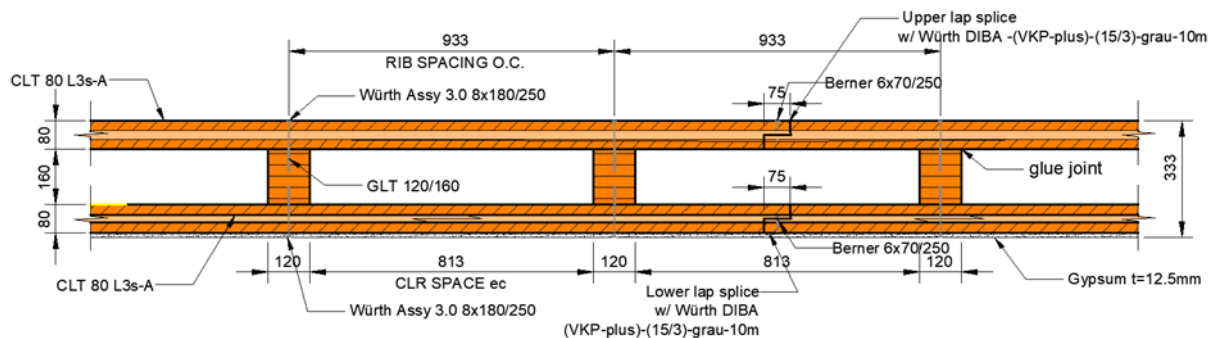

The following classes are applicable for floor construction when the maximum moment of 48.88 kNm/m of the floor is not exceeded.

The CLT rib panel – closed; with a gypsum board ceiling structure is classified as **REI 120, RE 120 and R 120** in accordance with EN 13501-2

The applicable field of application is:

- The maximum moments and shear forces, which when calculated on the same basis as the test load, shall not be greater than those tested.
- The size of panels of the ceiling lining may be increased by a maximum of 5 % but limited to a maximum of 50 mm. The length of the grid members can be increased accordingly.
- The total area occupied by fixtures and fittings relative to the area of the ceiling lining is not increased and the maximum tested opening in the lining is not exceeded.
- The height of the cavity (h) and the minimum distance (d) between the ceiling and the structural members (see drawing above) are equal to or greater than those tested.
- No material is added to the cavity.