

## Multilayer kraft back board

CKB 2WPE is a two-side polyethylene-coated multilayer kraft back board with a bleached chemical pulp layer on the top side and other layers made of CTMP and unbleached chemical pulp. The top side is coated with transparent PE and the reverse side is coated with white PE.

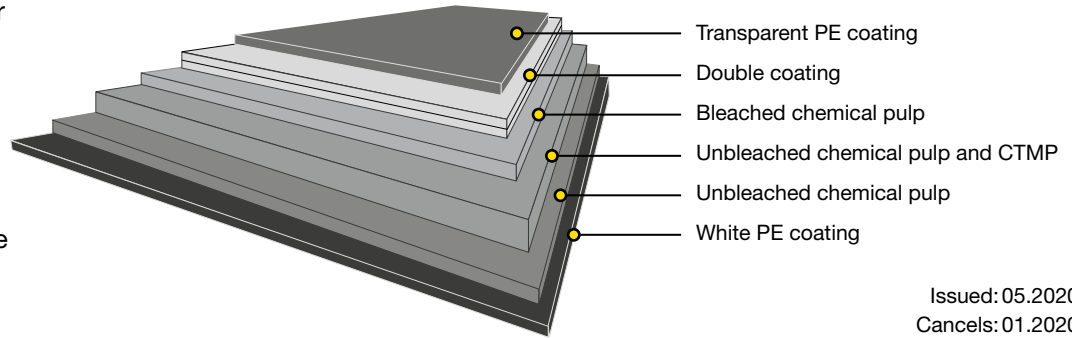

Issued: 05.2020  
Cancels: 01.2020

### Technical specification

Property / Unit	Tolerance	15+195+20	15+220+20	15+235+20	15+255+20	15+270+20	15+290+20	15+315+20	15+350+20	15+380+20	15+415+20	Standards
<b>Polymer coated board:</b>												
Grammage, g/m <sup>2</sup>		230	255	270	290	305	325	350	385	415	450	ISO 536
PE topside, g/m <sup>2</sup>		15	15	15	15	15	15	15	15	15	15	Mill method
PE reverse, g/m <sup>2</sup>		20	20	20	20	20	20	20	20	20	20	
Thickness, µm		335	395	435	470	485	525	575	635	700	745	ISO 534
<b>Baseboard:</b>												
Grammage, g/m <sup>2</sup>	±4%	195	220	235	255	270	290	315	350	380	415	ISO 536
Thickness, µm	±5%	300	360	400	435	450	490	540	600	665	710*	ISO 534
Bending moment Taber 15° MD, mNm	-15%	7.8	12.0	15.3	20.2	24.0	29.5	37.4	46.9	56.4	77.0	TAPPI 489
Bending moment Taber 15° CD, mNm	-15%	3.7	5.7	7.3	9.6	10.0	12.8	16.2	20.4	24.5	31.0	
Bending resistance L&W 15° MD, mN	-15%	160	250	319	416	495	611	775	971	1168	1585	ISO 2493
Bending resistance L&W 15° CD, mN	-15%	76	119	152	198	210	266	336	422	508	635	
Bending stiffness DIN 5° MD, mNm		14.0	22.0	28.0	38.0	43.0	56.0	71.0	96.0	109.0	163.0	DIN 53121
Bending stiffness DIN 5° CD, mNm		7.0	10.0	14.0	18.0	19.0	24.0	31.0	40.0	47.0	65.0	
Moisture, %	±1	7.0	7.0	7.5	7.5	7.5	8.0	8.5	9.0	9.5	9.5	ISO 287
ISO Brightness C/2°, %, Top	min. 78	80	80	80	80	80	80	80	80	80	80	ISO 2470-1
Surface Smoothness, PPS 10, µm, Top	max. 2.5	1.5	1.5	1.5	1.5	1.5	1.5	1.5	1.5	1.5	1.5	ISO 8791-4
Gloss 75°, %		35	35	35	35	30	30	30	30	30	30	ISO 8254-1
Scott Bond, J/m <sup>2</sup>	min. 100	175	175	175	175	175	175	175	175	175	175	TAPPI 569
Edge wicking, g/mm.m	max. 1.0	0.5	0.5	0.5	0.5	0.5	0.5	0.5	0.5	0.5	0.5	
Tearing resistance, GM, mN		2400	3000	3300	3700	4150	4600	5100	5700	6400	6500	TAPPI 496
Cobb 60, g/m <sup>2</sup> , Top		30	30	30	30	30	30	30	30	30	30	ISO 535
Robinson chocolate test		< 1 for one year stored under normal conditions										EN1230-2

Produced with RaZoR concept  
\*) +5%/-3.5% tolerance

All properties according to Skoghall Mill measurements from board machine production.  
Wet tearing resistance is typically 25-30% of dry tearing resistance, except for CKB 350 gsm, CKB 380 gsm and CKB 415 gsm where the wet tearing resistance is 60% of dry tearing resistance.  
Laboratory test climate 23°C/50% RH (According to ISO 187).  
Tolerances based upon 95% confidence limits, apply to delivered reel/pallet average.  
Bending moment Taber 15° and Bending resistance L&W 15° are binding, Bending stiffness DIN 5° are indicative.  
Bending moment Taber 15° calculated from Bending resistance L&W 15°.

### Certificates

Quality management ISO 9001  
 Environmental management ISO 14001  
 Product safety FSSC 22000  
 Health and safety OHSAS 18001  
 Energy management ISO 50001



FSC and PEFC certified board available upon request.



Paperboard is recyclable

### Key characteristics and main enduses

CKB 2WPE is all about strong character, strong brands and strong messages. It is an ideal packaging material for applications that require protection against humidity. The material offers exceptional stiffness and strength, combined with great runnability. One of the most important reasons to choose CKB 2WPE is its proven food safety. In addition, CKB 2WPE helps optimize package performance, ensures high visual quality, saves materials and, in food packaging, helps reduce food waste.

### Printing and finishing techniques

The product can be used with different printing techniques such as offset, flexo and digital printing. In digital printing, the product is suitable for several different sheet- or web-fed presses. Inkjet, dry or liquid toner technology can be used, although in some cases, pretreatment of the substrate might be required. The latest certification status can be verified on the press manufacturer's website or with local Stora Enso representatives. It is important to check the limitations of the equipment, particularly because of the exceptional difference in the thickness and stiffness of board compared with paper in the same grammages. When running thicker substrates, the press manufacturer's recommendations should be referred to for optimal grain direction. Essentially all of the same finishing processes apply to both digitally printed and offset printed work. Since a wide variety of digital printing equipment is available in the market, it is important that a new commercial print job is always preceded by a trial run, including all required printing and converting process phases. The product works very well with different finishing techniques, such as embossing, hot foil stamping and others. It is suitable for laser coding. Certificate according to PTS-DF 105/2013 is available upon request.

### Storage recommendations

For optimal printing results, the moisture proof wrapping should not be removed until the board has reached the temperature of the press room.

Pallet/Reel Weight (kg)	Difference in temperature between board and press room (press room temp. approx. 20°C)		
	10°C	20°C	30°C
400 kg	2 days	2 days	3 days
800 kg	2 days	3 days	4 days
1200 kg	2 days	4 days	5 days

The product properties, according to the specifications, are guaranteed for 12 months after the production date. In order to ensure product safety, the product must be well wrapped and stored indoors, sheltered from rain and snow. The recommended storage conditions are 50-55% relative humidity and 20-23°C.

For the Corona treatment, we recommend using the board within 12 months of the production date; after this period, the treatment level should be tested before printing or gluing.

