

CKB Nude is an uncoated, brown, multilayer kraft back board made of unbleached chemical pulp and additional CTMP in the middle layer. The all-brown board has a natural look and feel, and is fully made of virgin fibre.

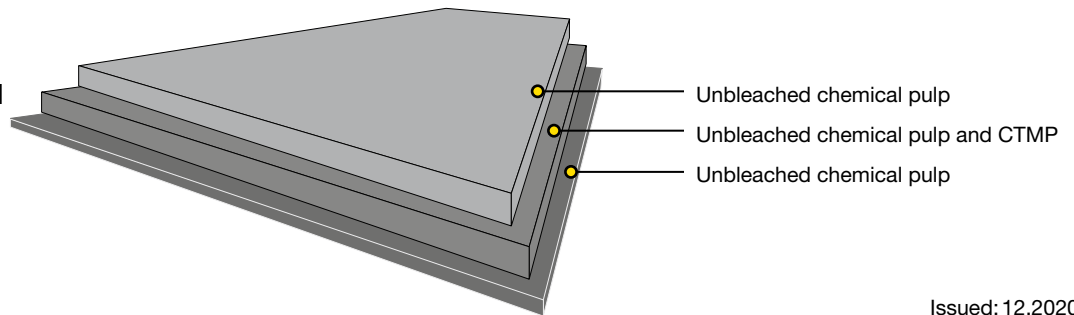

Issued: 12.2020
Cancels: 08.2017

Technical specification

Typical properties, US	Tolerance					Method	
Caliper, pts		15.0	17.5	19.5	22.8	24.8	
Nominal basis weight, lb/1000 sq. Ft.		42.0	47.1	52.2	66.6	70.7	
Bending moment Taber 15° MD, gcm		131	196	268	509	623	
Bending moment Taber 15° CD, gcm		52	78	107	204	250	
Tearing resistance MD, gf		296	347	398	510	551	
Tearing resistance CD, gf		337	387	438	581	632	
Typical properties, Metric	Tolerance					Method	
Thickness, µm	±5%	380	445	495	580	630	ISO 534
Nominal basis weight, g/m ²	±4%	205	230	255	325	345	ISO 536
Bending moment Taber 15° MD, mNm	-15%	12.9	19.2	26.3	49.9	61.1	TAPPI 489 om-99
Bending moment Taber 15° CD, mNm	-15%	5.1	7.7	10.5	20.0	24.5	TAPPI 489 om-99
Bending resistance L&W 15° MD, mN	-15%	266	400	544	1032	1265	ISO 2493
Bending resistance L&W 15° CD, mN	-15%	106	160	218	413	506	ISO 2493
Moisture, %	±1	7.5	7.5	7.5	8.0	8.5	ISO 287
Surface Smoothness, Bendtsen, ml/min, Top	max 700	400	400	400	400	400	SCAN P 84:02
Surface Smoothness, Bendtsen, ml/min, Reverse	max 2000	700	700	700	700	700	SCAN P 84:02
Tearing resistance MD, mN	-800	2900	3400	3900	5000	5400	TAPPI 496 sp-99
Tearing resistance CD, mN	-800	3300	3800	4300	5700	6200	TAPPI 496 sp-99
Cobb 60, g/m ² , Top		30	30	30	30	30	ISO 535
Cobb 60, g/m ² , Reverse		30	30	30	30	30	ISO 535

Certificates

Quality management ISO 9001
 Environmental management ISO 14001
 Product safety FSSC 22000
 Health and safety OHSAS 18001
 Energy management ISO 50001



FSC and PEFC certified board available upon request.

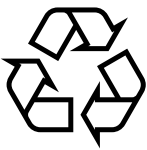

Paperboard is recyclable

Key characteristics and main enduses

CKB Nude has been designed to meet consumer preferences for sustainable, renewable and recyclable packaging materials with a natural look and feel. Made from pure virgin fibre, CKB Nude is a safe choice for food packaging but also for many other products, such as beverage, cosmetics and luxury packaging. CKB Nude provides a fantastic opportunity to differentiate a brand on the shelf. Its eye-catching and organic appeal embraces the beauty of nature's own shades of brown – creating a look that is both timeless and trendy. CKB Nude offers great stiffness, strength, runnability and convertibility.

Printing and finishing techniques

The product can be used with different printing techniques such as offset, flexo and digital printing. In digital printing, the product is suitable for several different sheet- or web-fed presses. Inkjet, dry or liquid toner technology can be used, although in some cases, pretreatment of the substrate might be required. The latest certification status can be verified on the press manufacturer's website or with local Stora Enso representatives. It is important to check the limitations of the equipment, particularly because of the exceptional difference in the thickness and stiffness of board compared with paper in the same grammages. When running thicker substrates, the press manufacturer's recommendations should be referred to for optimal grain direction. Essentially all of the same finishing processes apply to both digitally printed and offset printed work. Since a wide variety of digital printing equipment is available in the market, it is important that a new commercial print job is always preceded by a trial run, including all required printing and converting process phases. The product works very well with different finishing techniques, such as embossing, hot foil stamping and others.

Storage recommendations

For optimal printing results, the moisture proof wrapping should not be removed until the board has reached the temperature of the press room.

Pallet/Reel Weight (kg)	Difference in temperature between board and press room (press room temp. approx. 68°F)		
	50°F	68°F	86°F
881 lbs	2 days	2 days	3 days
1763 lbs	2 days	3 days	4 days
2645 lbs	2 days	4 days	5 days

The product properties, according to the specifications, are guaranteed for 12 months after the production date. In order to ensure product safety, the product must be well wrapped and stored indoors, sheltered from rain and snow. The recommended storage conditions are 50-55% relative humidity and 68-73.4°F.