

Natura RFA CLC/F

Coated CTMP kraft back board

Natura RFA, Roll Fed Aseptic is an excellent board for liquid packaging in roll fed aseptic systems. This board is a coated multilayer kraft back liquid packaging board with a three layer fibre construction with a reverse ply made of unbleached sulphate pulp, a middle ply of CTMP (chemi-thermomechanical pulp) and a top ply of bleached sulphate pulp with two layers of coating.

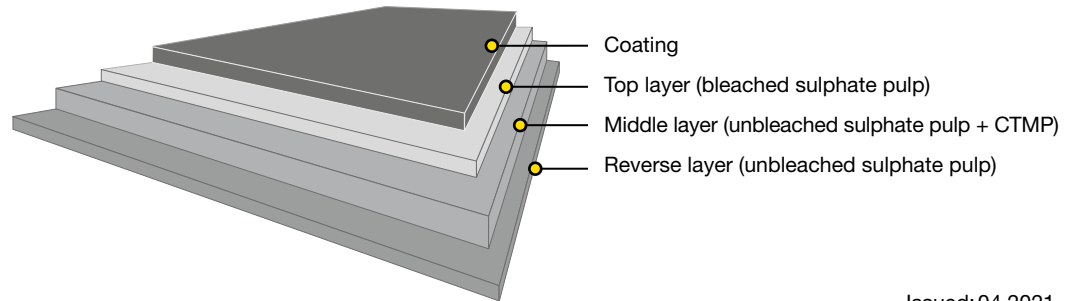

Issued: 04.2021
Cancels: 08.2020

Specification from Skoghall BM8; Natura RFA CLC/F Liquid Packaging Board:

Property/Unit					Standard
Grammage, g/m ²	195	215	231	270	ISO 536
Thickness, µm	262	299	330	409	ISO 534
Density, kg/m ³	744	719	700	660	
Bending resistance (L&W 15°) MD, mN	119	175	227	365	ISO 2493
Bending resistance (L&W 15°) CD, mN	54	75	99	184	
Bending resistance (L&W 15°) GM, mN	80	115	150	260	
Bending resistance ratio, MD/CD	2.2	2.3	2.3	2.0	
Tensile strength MD, kN/m	15.7	17.5	18.8	21.5	ISO 1924-3
Tensile strength CD, kN/m	8.0	8.6	9.2	10.5	
Tensile stretch MD, %	2.2	2.2	2.4	2.2	
Tensile stretch CD, %	5.3	5.1	5.5	5.0	
Moisture, %	7.0	7.0	7.0	7.5	ISO 287
Z-tensile strength, kPa	380	380	380	350	SCAN P 80:98
Scott Bond, J/m ²	200	200	200	200	TAPPI 569
Brightness (D65/10°) Top, %	79	79	79	79	ISO 2470-2
Colour L* (D65/10°) Top	92.7	92.7	92.7	92.7	ISO 5631-2
a* (D65/10°) Top	0.0	0.0	0.0	0.0	
b* (D65/10°) Top	2.2	2.2	2.2	2.2	
Roughness (Bendtsen) Top, ml/min	100	100	100	100	ISO 8791-2
Roughness (Bendtsen) Reverse, ml/min	600	600	700	1000	
Roughness (PPS) Top, µm	1.7	1.7	1.9	1.9	ISO 8791-4
Edge Wicking Lactic Acid (1h/23°C), kg/m ²	0.40	0.40	0.40	0.40	Stora Enso
Edge Wicking H ₂ O ₂ (10min/70°C), kg/m ²	0.80	0.80	0.80	0.80	

Natura RFA CLC/F

Coated CTMP kraft back board

Certificates

Quality management ISO 9001
 Environmental management ISO 14001
 Product safety FSSC 22000
 Occupational health and safety ISO 45001
 Energy management ISO 50001



FSC and PEFC certified board available upon request.

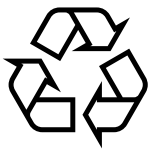

Paperboard is recyclable

Key characteristics and main enduses

Natura RFA offers the best in product protection, printing, converting and filling performance, economy and sustainability. Furthermore the coating layers contributes to excellent print result. Like all Stora Enso liquid packaging board qualities, it has an exceptionally high standard of odour and taint neutrality, which makes it especially suitable for packaging sensitive food products and keeping them fresh and hygienic, unchanged and untainted for their entire lifetime. The product range is covering the range from small portion to big family packages for aseptic juice and dairy products.

Storage recommendations

For optimal printing results, the moisture proof wrapping should not be removed until the board has reached the temperature of the press room.

Pallet/Reel Weight (kg)	Difference in temperature between board and press room (press room temp, approx 20°C)		
	10°C	20°C	30°C
400 kg	2 days	2 days	3 days
800 kg	2 days	3 days	4 days
1200 kg	2 days	4 days	5 days

The product properties, according to the specifications, are guaranteed for 12 months after the production date. In order to ensure product safety, the product must be well wrapped and stored indoors, sheltered from rain and snow. The recommended storage conditions are 50-55% relative humidity and 20-23°C.