

Performa Lumi™

Fully coated CTMP board with light pigment coated reverse, FiberLight Tec™

Performa Lumi is a pigment coated GCI board with a three-layer fiber construction and CTMP (chemi-thermomechanical pulp) in the middle layer, produced with patented FiberLight Tec™ production technology. It is multiple pigment coated on the top side, with one layer of pigment coating on the reverse side.

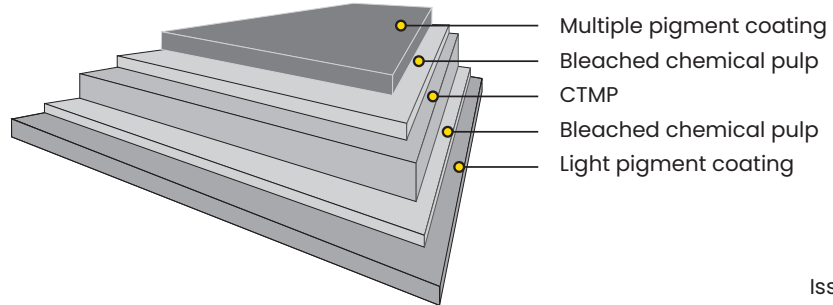

Issued: 05/2026
Replaces: 02/2026

Technical specification

Typical properties, Imperial	Unit							
Caliper	pts		12.0	14.0	16.0	18.0	20.0	
Nominal basis weight	lb/1000 sq. Ft.		42.0	47.1	52.2	57.3	63.5	
Bending moment Taber 15° MD	g/cm		95	144	193	261	361	
Bending moment Taber 15° CD	g/cm		44	65	88	118	164	
Scott Bond	Lbfft/1000 in²		71	71	71	71	71	
Typical properties, Metric		Tolerance						Method
Grammage	g/m²	±4%	205	230	255	280	310	ISO 536
Thickness	µm	±5%	305	356	406	457	508	ISO 534
Bending resistance L&W 15° MD	mN	-15%	193	292	391	530	733	ISO 2493
Bending resistance L&W 15° CD	mN	-15%	88	133	177	241	333	ISO 2493
Bending moment Taber 15° MD	mNm	-15%	9.3	14.1	18.9	25.6	35.4	
Bending moment Taber 15° CD	mNm	-15%	4.3	6.4	8.6	11.6	16.1	
Moisture	%	±1	7.0	7.6	8.0	8.3	9.0	ISO 287
ISO Brightness C/2°, Top	%	min. 87	90	90	90	90	90	ISO 2470-1
ISO Brightness C/2°, Reverse	%		88	88	88	88	88	ISO 2470-1
CIE Whiteness D65/10°, Top			120	120	120	120	120	ISO 11475
CIE Whiteness D65/10°, Reverse			114	114	114	114	114	ISO 11475
L*, D65/10°, Top			95	95	95	95	95	ISO 5631-2
a*, D65/10°, Top			2.5	2.5	2.5	2.5	2.5	ISO 5631-2
b*, D65/10°, Top			-7.2	-7.2	-7.2	-7.2	-7.2	ISO 5631-2
Surface Smoothness PPS10, Top	µm	max. 1.7	1.0	1.0	1.0	1.0	1.0	ISO 8791-4
Surface Smoothness PPS10, Reverse	µm	max. 8.4	6.5	6.5	6.5	6.5	6.5	ISO 8791-4
Gloss 75°	%		45	45	45	45	45	ISO 8254-1
Scott Bond	J/m²	min. 100	150	150	150	150	150	TAPPI 569 om-22
Cobb ₆₀ , Top	g/m²	max. 60	30	30	30	30	30	ISO 535
Cobb ₆₀ , Reverse	g/m²	max. 60	30	30	30	30	30	ISO 535
Robinson chocolate test	-		< 1 for one year storage in reels/pallets					ENI230-2

All properties according to mill measurements from board machine production. Laboratory test climate 23°C/50% RH (According to ISO 187). Tolerances based upon 95% confidence limits, apply to delivered reel/pallet average.

Bending moment Taber 15° calculated from Bending resistance L&W 15°.

Performa Lumi™

Fully coated CTMP board with light pigment coated reverse, FiberLight Tec™

Certificates

- Quality management ISO 9001
- Environmental management ISO 14001
- Food safety FSSC 22000
- Occupational health and safety ISO 45001
- Energy management ISO 50001



FSC and PEFC certified board available upon request.



Paperboard can be recycled

Key characteristics and main enduses

Performa Lumi is produced with patented FiberLight Tec™, a technology that creates exceptionally light and strong board, Performa Lumi is designed to be superiorly efficient.

Performa Lumi is an aesthetically appealing board that combines performance with a beautiful white appearance. This board is ideal for beauty & personal care, healthcare, but also for food applications like chocolate & confectionery or others. Performa Lumi has excellent smoothness giving a very good print result, and the reverse side is also suitable for full-colour printing. The high brightness and whiteness contribute to optimal visual appearance.

Printing and finishing techniques

The product can be used with different printing techniques such as offset, flexo and digital printing. In digital printing, the product is suitable for several different sheet- or web-fed presses. Inkjet, dry or liquid toner technology can be used, although in some cases, pretreatment of the substrate might be required. The latest certification status can be verified on the press manufacturer’s website or with local Stora Enso representatives. It is important to check the limitations of the equipment, particularly because of the exceptional difference in the thickness and stiffness of board compared with paper in the same grammages. When running thicker substrates, the press manufacturer’s recommendations should be referred to for optimal grain direction. Essentially all the same finishing processes apply to both digitally printed and offset printed work. Since a wide variety of digital printing equipment is available in the market, it is important that a new commercial print job is always preceded by a trial run, including all required printing and converting process phases. The product works very well with different finishing techniques, such as embossing, hot foil stamping and others. It is suitable for laser coding and ink jet marking. Certificates according to PTS-DF 105/2023 and PTS-DF 103/2022 are available upon request.

Storage recommendations

For optimal printing results, the moisture proof wrapping should not be removed until the board has reached the temperature of the press room.

Pallet/Reel Weight (lbs)	Difference in temperature between board and press room		
	50°F	68°F	86°F
881 lbs (400 kg)	2 days	2 days	3 days
1762 lbs (800 kg)	2 days	3 days	4 days
2643 lbs (1200 kg)	2 days	4 days	5 days

The product properties, according to the specifications, are guaranteed for 12 months after the production date. In order to ensure product safety, the product must be well wrapped and stored in its original cover indoors, sheltered from rain and snow. The recommended storage conditions are 50–55% relative humidity and 68–73.4°F.