

Fully coated CTMP board with light coated reverse

Performa Brilliance is a coated GC1 board with a three-layer fibre construction and CTMP (chemi-thermomechanical pulp) in the middle layer. It is triple-pigment-coated on the top side, with one layer of coating on the reverse side.

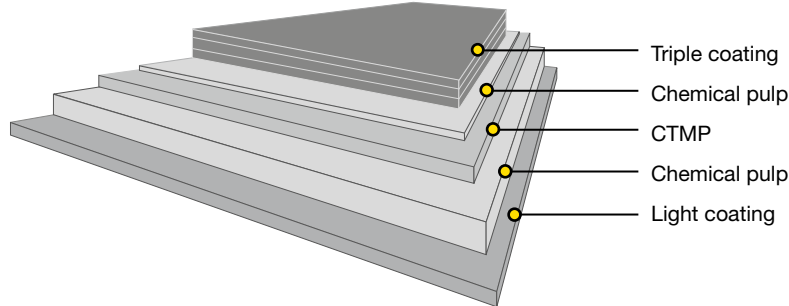

Issued: 02.2023
Cancels: 04.2021

Technical specification

Property / Unit	Tolerance													Standards
Grammage, g/m ²	±4%	180	200	215	230	245	260	280	300	320	345	370	395	ISO 536
Thickness, µm	±5%	255	305	330	360	390	415	455	495	535	585	625**	680**	ISO 534
Bending resistance L&W 15° MD, mN	-15%	108	147	186	224	286	343	430	515	618	765	908**	1070**	ISO 2493
Bending resistance L&W 15° CD, mN	-15%	53	72	91	110	140	167	210	250	303	375	445**	525**	
Bending moment Taber 15° MD, mNm	-15%	5.2	7.1	9.0	10.8	13.8	16.6	20.8	24.9	29.8	36.9	43.9**	51.7**	
Bending moment Taber 15° CD, mNm	-15%	2.6	3.5	4.4	5.3	6.8	8.1	10.1	12.1	14.6	18.1	21.5**	25.4**	
Bending stiffness DIN 5° MD, mNm	-15%	8.2	12.0	15.9	19.6	25.7	31.3	39.9	48.3	58.4	72.9	87.2**	104.2**	
Bending stiffness DIN 5° CD, mNm	-15%	4.4	6.2	8.0	9.9	12.8	15.4	19.6	20.1	28.6	35.6	43.2**	50.4**	
Moisture, %	±1	6.2	6.8	7.2	7.8	8.0	8.1	8.3	8.6	8.7	8.8	9.1	9.1	ISO 287
ISO Brightness C/2°, %, Top	min. 89	92	92	92	92	92	92	92	92	92	92	92	92	ISO 2470-1
ISO Brightness C/2°, %, Reverse	min. 87	90	90	90	90	90	90	90	90	90	90	90	90	
Brightness D65/10°, %, Top		98	98	98	98	98	98	98	98	98	98	98	98	ISO 2470-2
CIE Whiteness D65/10°, Top		122	122	122	122	122	122	122	122	122	122	122	122	ISO 11475
CIE Whiteness D65/10°, Reverse		120	120	120	120	120	120	120	120	120	120	120	120	
L*, Top		95.5	95.5	95.5	95.5	95.5	95.5	95.5	95.5	95.5	95.5	95.5	95.5	ISO 5631-2
a*, Top		1.9	1.9	1.9	1.9	1.9	1.9	1.9	1.9	1.9	1.9	1.9	1.9	
b*, Top		-7.5	-7.5	-7.5	-7.5	-7.5	-7.5	-7.5	-7.5	-7.5	-7.5	-7.5	-7.5	
Surface Smoothness, PPS 10, µm, Top	max. 1.5	1.0	1.0	1.0	1.0	1.0	1.0	1.0	1.0	1.0	1.0	1.0	1.0	ISO 8791-4
Surface Smoothness, PPS 10, µm, Reverse	max. 8.2	5.5	5.5	5.5	5.5	5.5	5.5	5.5	5.5	5.5	5.5	5.5	5.5	
Gloss 75°, %		40	40	40	40	40	40	40	40	40	40	40	40	ISO 8254-1
Scott Bond, J/m ²	min. 110	145	145	145	145	145	145	145	145	145	145	145	145	TAPPI 569
Edge wicking*, g/mm.m	max. 1.0	0.5	0.5	0.5	0.5	0.5	0.5	0.5	0.5	0.5	0.5	0.5	0.5	
Cobb 60, g/m ² , Top	max. 60	30	30	30	30	30	30	30	30	30	30	30	30	ISO 535
Cobb 60, g/m ² , Reverse	max. 60	30	30	30	30	30	30	30	30	30	30	30	30	

*) For hardsized
**) The values are preliminary

All properties according to Fors Mill measurements from board machine production.
Laboratory test climate 23°C/50% RH (According to ISO 187).
Tolerances based upon 95% confidence limits, apply to delivered reel/pallet average.
Bending moment Taber 15° and Bending resistance L&W 15° are binding, Bending stiffness DIN 5° are indicative.
Bending moment Taber 15° calculated from Bending resistance L&W 15°.

Certificates

Quality management ISO 9001
 Environmental management ISO 14001
 Product safety FSSC 22000
 Occupational health and safety ISO 45001
 Energy management ISO 50001
 EU Ecolabel standard contract FI/011/002, fulfil the ecological criteria for Graphic Paper, (EU) 2019/70, L15/27 (17.1.2019).



FSC and PEFC certified board available upon request.



EU Ecolabel: FI/011/002

The EU Ecolabel confirms that the board fulfils the European Commission's ecological criteria for copying and graphic paper and is therefore only available for graphical end uses.

EU Ecolabel available upon request on graphical end uses.



Paperboard is recyclable

Key characteristics and main enduses

The key characteristics of Performa Brilliance include high brightness, excellent smoothness and great visual appearance. The board offers the most superior whiteness in the FBB market on both the top and reverse side. Performa Brilliance has been specially designed for advanced graphical and high-end packaging applications. It is ideal for folding cartons for pharmaceuticals, cosmetics and luxury packaging. The quality and versatility of Performa Brilliance make it attractive for premium brands, and it is just brilliant for graphical applications such as book covers, greeting cards, folders, tickets and tags. Thanks to a triple-coated top side, Performa Brilliance gives an excellent print result, and the reverse side is also suitable for full-colour printing.

Printing and finishing techniques

The product can be used with different printing techniques such as offset, flexo, rotogravure and digital printing. In digital printing, the product is suitable for several different sheet- or web-fed presses. Inkjet, dry or liquid toner technology can be used, although in some cases, pretreatment of the substrate might be required. The latest certification status can be verified on the press manufacturer's website or with local Stora Enso representatives. It is important to check the limitations of the equipment, particularly because of the exceptional difference in the thickness and stiffness of board compared with paper in the same grammages. When running thicker substrates, the press manufacturer's recommendations should be referred to for optimal grain direction. Essentially all of the same finishing processes apply to both digitally printed and offset printed work. Since a wide variety of digital printing equipment is available in the market, it is important that a new commercial print job is always preceded by a trial run, including all required printing and converting process phases.

The product works very well with different finishing techniques, such as embossing, hot foil stamping and others. It is suitable for laser coding. Certificate according to PTS-DF 105/2013 is available upon request.

Storage recommendations

For optimal printing results, the moisture proof wrapping should not be removed until the board has reached the temperature of the press room.

Pallet/Reel Weight (kg)	Difference in temperature between board and press room (press room temp. approx. 20°C)		
	10°C	20°C	30°C
400 kg	2 days	2 days	3 days
800 kg	2 days	3 days	4 days
1200 kg	2 days	4 days	5 days

The product properties, according to the specifications, are guaranteed for 12 months after the production date. In order to ensure product safety, the product must be well wrapped and stored in its original cover indoors, sheltered from rain and snow. The recommended storage conditions are 50-55% relative humidity and 20-23°C.