

Trayforma Special™ PET

Pigment coated tray board for conventional and microwave oven

Trayforma Special is a bleached virgin-fibre board with a three layer fibre construction and with CTMP (chemi-thermomechanical pulp) in the middle layer. It has pigment coating on the top side and a white or black PET coating on the reverse.

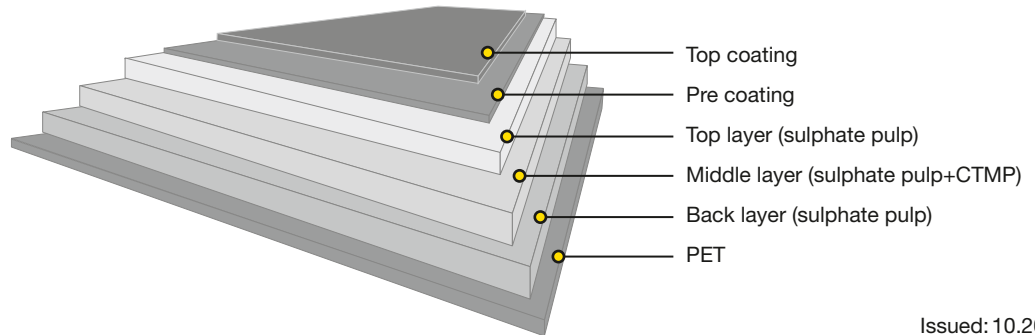

Issued: 10.2020
Cancels: 08.2019

Technical specification

Property/Unit	Tolerance	195+50	210+50	230+50	255+50	270+50	295+50	320+50	350+50	Standard
PET coated board:										
Grammage, g/m ²	± 7 %	245	260	280	305	320	345	370	400	ISO 536
PET reverse, g/m ²	± 5	50	50	50	50	50	50	50	50	Mill method
Thickness, µm	± 8 %	290	310	350	380	420	460	500	540	ISO 534
Baseboard:										
Grammage, g/m ²	±6%	195	210	230	255	270	295	320	350	ISO 536
Thickness, µm	±8%	260	280	320	350	390	430	470	510	ISO 534
Bending resistance L&W 15° MD, mN	min -20%	120	155	215	270	360	475	600	760	ISO 2493-1
Bending resistance L&W 15° CD, mN	min -20%	55	70	95	125	170	210	270	340	
Moisture %	min 5.0%	6.5	6.5	6.5	6.5	6.5	6.5	6.5	6.5	ISO 287
Brightness D65/10, Top		85	85	85	85	85	85	85	85	ISO 2470-2
Surface Smoothness, PPS 10, µm, Top	max 1.7	1.2	1.2	1.2	1.2	1.2	1.2	1.2	1.2	ISO 8791-4
Surface Smoothness, Bendtsen, ml/min	max 130	40	40	40	40	50	50	50	50	ISO 8791-2
Stretch CD, %		6.0	6.0	6.0	6.0	6.0	6.0	6.0	6.0	ISO 1924-3

OBA non-added



Trayforma Special™ PET

Pigment coated tray board for conventional and microwave oven

Certificates

- Quality management ISO 9001
- Environmental management ISO 14001
- Product safety FSC 22000
- Product safety ISO 22000
- Occupational health and safety ISO 45001
- Energy management ISO 50001



FSC and PEFC certified board available upon request.



Paperboard is recyclable

Key characteristics and main enduses

Trayforma Special is an eco-friendly high-quality board specially designed for lids and folded trays. Trayforma Special is food-safe, ecological as a renewable material, and offers a superb print result in flexographic and offset printing.

With high heat-resistant white PET coating, trays made of Trayforma PET can be used for heating or warming up prepared and semi-prepared foods. The PET coating also provides protection against humidity, grease, and oxygen.

Printing and finishing techniques

The product can be used for flexo and offset printing. It is important to ensure that also the ink and varnish to be used are suitable for high temperatures in the oven use. It is important to check possible limitations of the printing and converting equipment and ensure that the basis weight of the board fits the tooling to be used.

Storage recommendations

For optimal printing results, the moisture proof wrapping should not be removed until the board has reached the temperature of the press room.

Pallet/Reel Weight (kg)	Difference in temperature between board and press room (press room temp. approx. 20°C)		
	10°C	20°C	30°C
400 kg	2 days	2 days	3 days
800 kg	2 days	3 days	4 days
1200 kg	2 days	4 days	5 days

The product properties, according to the specifications, are guaranteed for 12 months after the production date. In order to ensure product safety, the product must be well wrapped and stored indoors, sheltered from rain and snow. The recommended storage conditions are 50-55% relative humidity and 20-23°C.